

AMENDMENT TO CONTRACT
Annual Supply
Workstations and Accessories
Bid No. 17-140
City of Lincoln, Lancaster County and
City of Lincoln-Lancaster County Public Building Commission
Renewal with Price Increase & Revision of New Workstations
Office Interiors & Design, Inc.

This Amendment is hereby entered into by and between Office Interiors & Design, Inc., 1401 Dahlberg Drive, Ste. A, Lincoln, NE 68512 hereinafter "Contractor") and the City of Lincoln, Lancaster County and the City of Lincoln-Lancaster County Public Building Commission (hereinafter "Owners"), for the purpose of amending the Contract dated August 10, 2017 executed under City Directorial Order No. 17628, and County Contract C-17-0646, dated August 15, 2017, and executed by the City of Lincoln-Lancaster County Public Building Commission, on September 12, 2017, for Annual Supply - Workstations and Accessories, Bid No. 17-140, which is made a part of this amendment by this reference.

WHEREAS, the original term of the Contract is September 12, 2017 through September 11, 2018, with the option to renew for three (3) additional one (1) year terms upon written mutual consent by all parties; and

WHEREAS, the Contract was amended by City Executive Order No. 92265, executed by the City on September 10, 2018, and by County Contract C-18-0539 executed by the County Board on September 11, 2018, and executed by the City of Lincoln-Lancaster County Public Building Commission on September 18, 2018, to renew the contract for an additional one (1) year term from September 12, 2018 through September 11, 2019; and

WHEREAS, the parties hereby renew the Contract for an additional one (1) year term beginning September 12, 2018 through September 11, 2019; and

WHEREAS, the parties hereby amend the Contract to reflect revision of new workstations and price increase as listed per Attachment A; and

WHEREAS, the expenditures for the City of Lincoln for the term of this renewal shall not exceed \$40,000.00 without approval by the City of Lincoln; and

WHEREAS, the expenditures for Lancaster County for the term of this renewal shall not exceed \$15,000.00 without approval by the Lancaster County Board; and

WHEREAS, the expenditures for the City of Lincoln-Lancaster County Public Building Commission for the term of this renewal shall not exceed \$500.00 without approval by the Public Building Commission; and

NOW, THEREFORE, IN CONSIDERATION of the mutual covenants contained in the Contract under City Directorial Order No. 17628 and County Contract C-17-0646, all amendments thereto, and as stated herein, the parties agree as follows:

- 1) The parties hereby renew the Contract for an additional one (1) year term beginning September 12, 2019 through September 11, 2020.
- 2) The parties hereby amend the Contract to reflect revision of new workstations and price increase as listed per Attachment A.
- 3) The expenditures for the City of Lincoln for the term of this renewal shall not exceed \$40,000.00 without approval by the City of Lincoln.
- 4) The expenditures for Lancaster County for the term of this renewal shall not exceed \$15,000.00 without approval by the Lancaster County Board.

- 5) The expenditures for the City of Lincoln-Lancaster County Public Building Commission for the term of this renewal shall not exceed \$500.00 without approval by the Public Building Commission.
- 6) All other terms of the Contract, not in conflict with this Amendment, shall remain in force and effect.

The Parties do hereby agree to all the terms and conditions of this Amendment. This Amendment shall be binding upon the parties, their heirs, administrators, executors, legal and personal representatives, successors, and assigns.

IN WITNESS WHEREOF, the Parties do hereby execute this Amendment upon completion of signatures on:

Vendor Signature Page
City of Lincoln Signature Page
Lancaster County Signature Page
City of Lincoln-Lancaster County Public Building Commission Signature Page

Vendor Signature Page

**AMENDMENT TO CONTRACT
Annual Supply
Workstations and Accessories
Bid No. 17-140
City of Lincoln, Lancaster County and
City of Lincoln-Lancaster County Public Building Commission
Renewal with Price Increase & Revision of New Workstations
Office Interiors & Design, Inc.**

Please sign, date and return within 5 days of receipt.

Mail to: City/County Purchasing
Attn: Debbie Winkler
440 So. 8th St., Ste. 200
Lincoln, NE 68508
Or email to: dwinkler@lincoln.ne.gov

Company Name:	OFFICE Interiors & Design
By: (Please Sign)	Nancy Kraft
By: (Please Print)	Nancy Kraft
Title:	Director of workplace solutions
Company Address:	1401 Dahlberg Drive. Ste A
Company Phone & Fax:	402 484 7500
E-Mail Address:	nancy.kraft@oidinc.com
Date:	9/3/19
Contact Person for Orders or Service	Nancy Kraft
Contact Phone Number:	402 730 7262

City of Lincoln Signature Page

**AMENDMENT TO CONTRACT
Annual Supply
Workstations and Accessories
Bid No. 17-140
City of Lincoln, Lancaster County and
City of Lincoln-Lancaster County Public Building Commission
Renewal with Price Increase & Revision of New Workstations
Office Interiors & Design, Inc.**

EXECUTION BY THE CITY OF LINCOLN, NEBRASKA

ATTEST:

City Clerk

CITY OF LINCOLN, NEBRASKA

Leirion Gaylor Baird, Mayor

Approved by Executive Order No. _____

dated _____

Lancaster County Signature Page

**AMENDMENT TO CONTRACT
Annual Supply
Workstations and Accessories
Bid No. 17-140
City of Lincoln, Lancaster County and
City of Lincoln-Lancaster County Public Building Commission
Renewal with Price Increase & Revision of New Workstations
Office Interiors & Design, Inc.**

EXECUTION BY LANCASTER COUNTY, NEBRASKA

Contract Approved as to Form:

The Board of County Commissioners of
Lancaster, Nebraska

Deputy Lancaster County Attorney

dated _____

**City of Lincoln-Lancaster County Public Building Commission
Signature Page**

**AMENDMENT TO CONTRACT
Annual Supply
Workstations and Accessories
Bid No. 17-140
City of Lincoln, Lancaster County and
City of Lincoln-Lancaster County Public Building Commission
Renewal with Price Increase & Revision of New Workstations
Office Interiors & Design, Inc.**

EXECUTION BY LINCOLN-LANCASTER COUNTY PUBLIC BUILDING COMMISSION

ATTEST:

Public Building Commission Attorney

Chairperson, Public Building Commission

dated _____

Prepared for:



BID NUMBER: 17-140

Ergonomics Workstations & Accessories Bid

REVISED: August 2019



ELECTRIC / HEIGHT ADJUSTABLE / COMPLETE DESK



TEKNION / HISPACE ELECTRIC DESK

**Complete Height Adjustable Desk w/ Top*

<http://www.teknion.com/ca/products/galleries/hispace-gallery>

- Foundation HPL Laminate Top
- Platinum (Silver) Metal Base
- Memory Display Switch
- 200lb Rise Capacity
- Range: 25.5" – 50.5"H

24"D x 48"W	\$674.00
-------------	----------

30"D x 60"W	\$725.00
-------------	----------

30"D x 72"W	\$753.00
-------------	----------

(*Available 24-30"D x 48-72"W)

Installation Estimate	\$150
-----------------------	-------



ELECTRIC / HEIGHT ADJUSTABLE / BASE ONLY

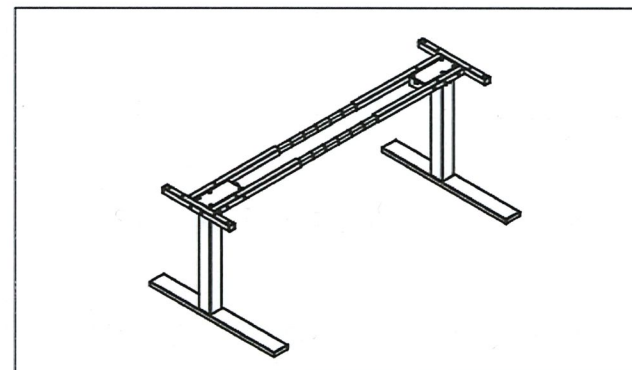

TEKNION / HiSPACE ELECTRIC BASE ONLY

**Base Only (For retrofitting existing rectangle tops)*

<http://www.teknion.com/ca/products/galleries/hispace-gallery>

- Platinum (Silver) Metal Base
- (*Available 24-30"D x 48-72"W)
- Memory Display Switch
- 200lb Rise Capacity
- Range: 25.5" – 50.5"H

24"-30"D x 48"-72W \$563.00

(*Telescoping base fits under a variety of sized tops)

Installation Estimate \$125



ELECTRIC / HEIGHT ADJUSTABLE / BASE ONLY (Extended Corner)



ESI Victory-LX - 2 Leg Base Only
2VT-LX-C48-24/30

**Base Only (For retrofitting existing extended corner desks)*

<https://www.esiergo.com/height-adjustable-tables/electric-table-bases/sp/victory-lx-2-leg/>

Silver Standard; White or Black optional
Basic Up/Down Switch
Range: 22" – 47"H
220lb Rise Capacity
Exceeds BIFMA x5.5 requirements

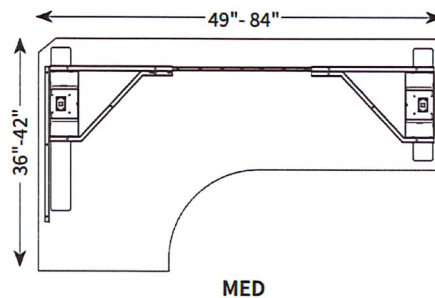

DIGITAL KEYPAD INCLUDED WITH BASE



- Digital programmable switch with 3 memory settings
- Keypad can slide under worksurface to store out of the way

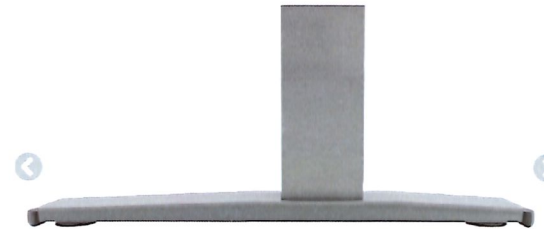

36-42"D x 48"-84W

\$573.00

(*Telescoping base fits under a variety of sized tops)

Installation Estimate

\$125



ELECTRIC / HEIGHT ADJUSTABLE / BASE ONLY (3-Leg)

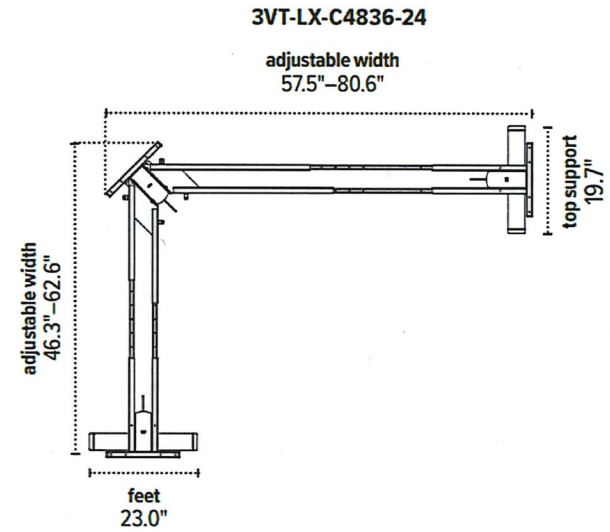

ESI Victory-LX - 3 Leg Base Only
3VT-LX-C4836-24

**Base Only (For retrofitting existing extended corner desks)*

<https://www.esiergo.com/height-adjustable-tables/electric-table-bases/sp/victory-lx-3-leg/>

Silver Standard; White or Black optional
Basic Up/Down Switch
Range: 22" – 47"H
320lb Rise Capacity
Exceeds BIFMA x5.5 requirements

48-84" D x 48"-84W	\$726.00
(*Telescoping base fits under a variety of sized tops)	
Installation Estimate	\$150



HEIGHT ADJUSTABLE / DESK MOUNTED



Humanscale's QuickStand Eco is the next generation in portable sit/stand solutions.

Sleeker, easier to use and comprised of more sustainable materials than ever before, it is a vast improvement over the current generation of sit/stand surfaces. QuickStand Eco features simple setup, portability and near effortless adjustability — transforming ordinary desktops into healthy, active workspaces.

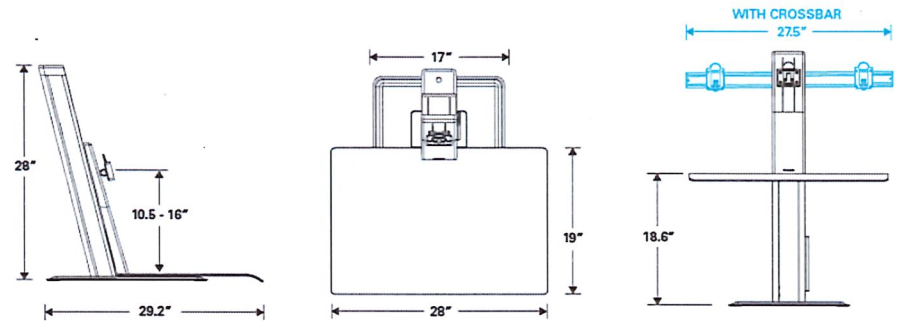

HUMANSCALE / QUICKSTAND ECO – Single or Double

<https://www.humanscale.com/products/product.cfm?group=quickstandeco>

White or Black

Dimensions: 28.1" H (in resting position) x 28" W x 29.2" D

Work Surface: 28" W (710mm) x 19" D (480mm)

Minimum Desk Required - 29" Product Weight:

Laptop - 38.5 lbs. (17.5 kg)

Single Monitor - 42.3 lbs. (19.2 kg)

Dual Monitor - 45 lbs. (20.5 kg)

Product Weight with Box:

Laptop - 51.2 lbs. (23.2 kg)

Single Monitor - 55.0 lbs. (24.9 kg)

Dual Monitor - 57.7 lbs. (26.2 kg)

Vertical Monitor Adjustment - 5"

Total Height Range - 18.6"

Single Monitor	\$413.45
Double Monitor	\$474.92
Installation for 1	\$85
2 or more call for quote	



HEIGHT ADJUSTABLE / DESK MOUNTED



HUMANSCALE / QUICKSTAND LITE – Single or Double

**Attaches to existing desktop – Clamp or Bolt Mounted*

<https://www.humanscale.com/products/product.cfm?group=quickstandlite>

Silver or Black

Weight capacity is 22lbs

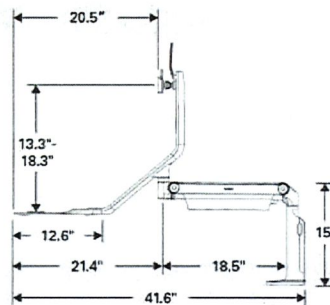

QuickStand Lite features an innovative counterbalance mechanism that enables users of varying heights to transition from sitting to standing positions with ease, offering 20" of total height range and an added 5.5" of vertical monitor adjustment. Its effortless functionality encourages users to be active throughout the day.



Light Single Monitor	\$497.45
Light Double Monitor	\$559.05
Installation	\$85



HEIGHT ADJUSTABLE / DESK MOUNTED



HUMANSCALE / QUICKSTAND

**Attaches to existing desktop – Clamp or Bolt Mounted*

(Also available as a freestanding base)

<https://www.humanscale.com/products/product.cfm?g>

Black or White

Monitors up to 30lbs

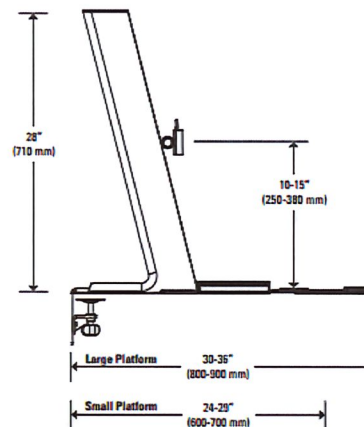

Single Heavy, Small Platform	\$703.57
Single Heavy, Large Platform	\$733.75

Standard Double, Small Platform	\$736.65
Standard Double, Large Platform	\$766.85

Wide Double, Small Platform	\$745.94
Wide Double, Large Platform	\$776.13

Installation	\$85
--------------	------



MONITOR ARMS



INNOVATIVE / Winston Desk 2

Available in two sizes: 36" and 36" corner

Spring assisted to raise and lower in seconds
Upper desk surface has a 10mm bolt-thru hole for mounting an optional monitor arm.

Ships fully assembled, no installation required.

5 Year Warranty

Black or White

36"W	\$358.00
36" W corner	\$369.00
Freight	\$28.00 EACH
Installation for 1	\$65
2 or more call for quote	



KEYBOARD TRAYS

6G90090HG22	\$201.93
Installation	\$55

(Balance-M/TRACKLESS)-(LO	\$255
Installation	\$55

SOLUTIONULTRA	\$239.75
Installation	\$55

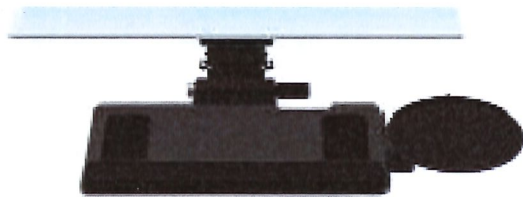

HUMANSCALE / KEYBOARD TRAY

6G90090HF22

https://www.humanscale.com/products/category_detail.cfm?category=keyboard_systems

Black
 Standard Mechanism / Platform
 9" Clip Mouse High
 19" Foam Palm Support w/ Synthetic Leather Cover
 22" Track Length

*Installation labor to be quoted as required; including vendor to perform a site visit to measure and determine proper needs of the workspace.



SYMMETRY / TRACKLESS KEYBOARD TRAY (for Height Adjustable Worksurfaces)

Balance-M/TRACKLESS)-(LO

<http://www.symmetryoffice.com/tableBuilder/index.cfm?pid=245>

Black
 Standard Mechanism for Height Adjustable Surfaces
 Includes Mouse Pad and Mouse Guard



ESI / KEYBOARD TRAY

SOLUTIONULTRA

<https://www.esiergo.com/keyboard-solutions/combo-solutions/sp/solution-ultra/>

PL217 SWITCH-N-CLICK PLATFORM
 18.75" keyboard platform
 9.25" Switch-n-Click mousing platform

Designed to complement radius corner work surfaces and position the keyboard closer to the work area.

AA360 ARTICULATING ARM
 21" glide track, Lift and Lock
 7" height adjustment
 High: 2.5" above track
 Low: 4.5" below track



MONITOR ARMS

DOUBLE MONITOR ARM

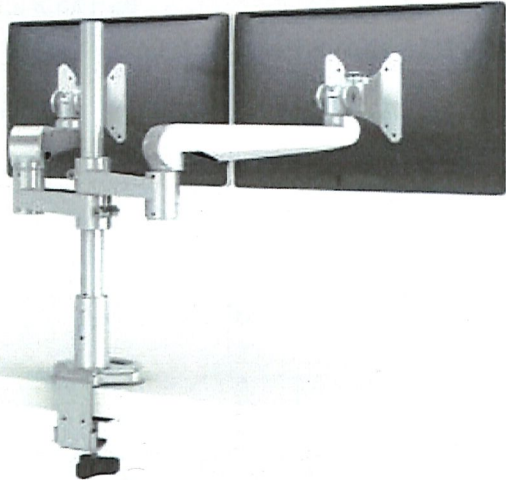

SINGLE MONITOR ARM

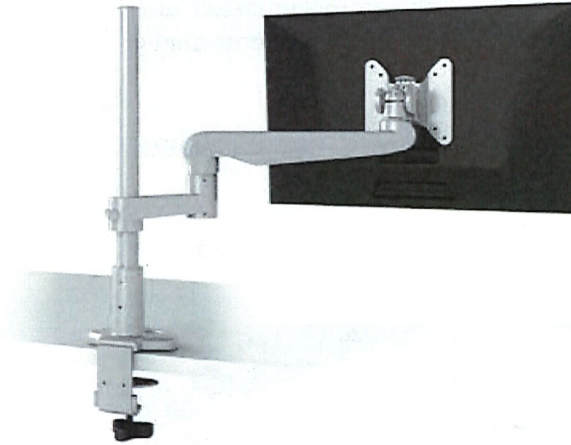

ESI / EVOLVE-F

EVOLVE1-F // EVOLVE2-F

<https://www.esiergo.com/monitor-arms/single/sp/evolve1-f/>

<https://www.esiergo.com/monitor-arms/dual/sp/evolve2-f/>

Single and Dual Monitor Arm.
Manual Height Adjustment.

Monitor Extension: 16.25"
 Monitor Retraction: 3"
 Monitor Tilt: +90°/-25°
 Monitor Rotation: +90°/-90°
 Weight Capacity (per arm):
 Maximum: 20 lbs
 180° Lock-Out Feature
 Quick Release
 16" Pole
 Desk clamp & grommet mount included
 Max Monitor Width: 27" (bezel measured left to right)

Single Monitor Arm	\$159.35
Double Monitor Arm	\$254.90
Freight	\$25.00 ea
Installation	\$55



MONITOR ARMS

M21CMSBTB	\$167.49
Installation	\$55

*Installation labor to be quoted as required; including vendor to perform a site visit to measure and determine proper needs of the workspace.

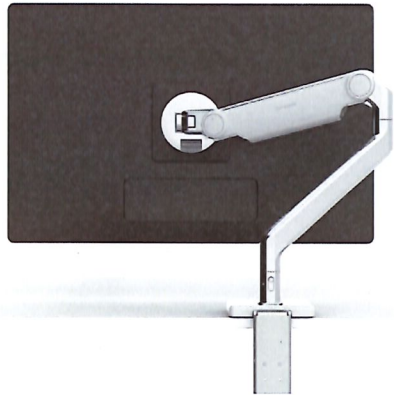

HUMANSCALE / M2.1 SINGLE

M21CMSBTB

Silver with grey trim
 Desk Clamp Mount OR Bolt Through Mount
 angled Link / Dynamic Link Arm Style
 Standard VESA Plate

DOUBLE	\$362.23
Installation	\$55



HUMANSCALE / MFLEX

X2BCMSETB9TK

Smart stop allows the user to customize the rotation of the arm, preventing overhang
 Silver
 Bolt or Clamp Mount
 Can add up to 6 monitors
 Standard VESA Plate



VALUES

EXCELLENT

Office Interiors & Design is committed to excellence in all aspects of interior design and furniture products and services; in communication, space planning and design, CAD drawing, furniture specification, finish selection, order placement, receiving, warehousing, installation and client wrap-up; in the hiring of the absolute best people and continuing professional development of everyone; in all administrative policies and procedures; and participation in the communities that fuel the continual reinvigoration of the interior design community.

LISTENING

Remaining ever mindful that each client is a unique individual or group, with unique and specific requirements, the employees of OID are committed to sharing the client vision; through active listening, providing thoughtful, individualized solutions, and remaining flexible of mind, the shared vision is attained.

STEWARDSHIP

As a mid-western, family owned company we recognize that our company's strength comes from our people; and that our people come from our community. OID is committed to fostering a love of design in young people and we pledge to continue to support local design students and curricula.

KNOWLEDGE

OID has extensive experience and product expertise across many markets; including corporate, government, public spaces, technology and higher education. From top to bottom, we understand the specific markets we serve.

We utilize the latest technology to accommodate client needs quickly. Planning, specifications, ordering and tracking orders are managed in a way that ensures speed and accuracy.

PEOPLE

We pride ourselves on the knowledge, expertise and professionalism of our entire company. Many of our employees have been with the company for over 15 years, and we are continually honored with an incredible employee retention rate as well as a commitment to ongoing training.

Our service team is comprised of extremely dependable and professional individuals that continue to reinforce the positive experience of working with our company.

MISSION

Office Interiors & Design, Inc. is a full-service commercial furniture dealership dedicated to delivering an enjoyable, professional client experience; ever-striving to realize the client vision while strictly adhering to budget and schedule.

OID was founded by Dian Pickerel in 1995 and remains a family-owned, women-owned business.

OID is a client-first company that positions itself for long-term success by committing to client delight.

OID is pledged to excellence of client experience and creating the amazing spaces of our client's vision and that the design, administrative and installation teams are trained experts; ready to assist clients in all phases of the process, communicate effectively, and create solutions.

Office Interiors & Design intends that its clients achieve all of their project goals and are delighted by the process and results.

VISION

Office Interiors & Design, Inc. is a preeminent regional commercial furniture dealership, where the furniture experience transforms every client into an earnest, vocal advocate of our firm.



SERVICES

OID is a single source resource for all commercial furniture needs across of variety of markets. We support clients from space planning through furniture assembly and move in, as well as post occupancy needs. It's our job to take the hassle out of creating smart furniture solutions.



DESIGN

We offer full design services including workplace strategy, typical development, 3D renderings, space planning, technical specification, fabric and finish selections, installation drawings and field verification.



CUSTOMIZATION

We help our clients achieve a vision that also fits with their organizations branding and goals. Our manufacturer partners allows us to customize everything from colors, finishes, fabrics, furniture design, and more. Each product is truly designed to order the way you want it.



PRODUCT SOLUTIONS

As workplace design and project management specialists, we help create and refine your vision for the office. We provide idea starters, full floor plan product selections, and offerings that fit within your budget.



PROJECT MANAGEMENT

Our experienced Project Leads provide you one point of contact to tailor your project to specific budget and schedule needs. Dedicated Project Leads guide you through every step including planning, installation and revisions.



INSTALLATION

We outline your schedule and communication plan, and our team will oversee the production and installation processes to ensure they run smoothly. We are committed to finishing well through our team, and our partner installers, of courteous, prompt and professional installers.



CERTIFICATE OF LIABILITY INSURANCE

DATE (MM/DD/YYYY) 07/03/2019

THIS CERTIFICATE IS ISSUED AS A MATTER OF INFORMATION ONLY AND CONFERS NO RIGHTS UPON THE CERTIFICATE HOLDER. THIS CERTIFICATE DOES NOT AFFIRMATIVELY OR NEGATIVELY AMEND, EXTEND OR ALTER THE COVERAGE AFFORDED BY THE POLICIES BELOW. THIS CERTIFICATE OF INSURANCE DOES NOT CONSTITUTE A CONTRACT BETWEEN THE ISSUING INSURER(S), AUTHORIZED REPRESENTATIVE OR PRODUCER, AND THE CERTIFICATE HOLDER.

IMPORTANT: If the certificate holder is an ADDITIONAL INSURED, the policy(ies) must have ADDITIONAL INSURED provisions or be endorsed. If SUBROGATION IS WAIVED, subject to the terms and conditions of the policy, certain policies may require an endorsement. A statement on this certificate does not confer any rights to the certificate holder in lieu of such endorsement(s).

PRODUCER: INSPRO Insurance, P.O. Box 6847, Lincoln, NE 68506, 402 483-4500. CONTACT NAME: Quentin Christensen, PHONE (A/C, No, Ext): 402-483-4500, FAX (A/C, No): 402-483-7977, E-MAIL ADDRESS: qchristensen@insproins.com. INSURER(S) AFFORDING COVERAGE: INSURER A: QBE Insurance Corporation (NAIC # 39217), INSURER B: SFM Mutual Insurance Co (NAIC # 11347), INSURER C, D, E, F.

COVERAGES CERTIFICATE NUMBER: REVISION NUMBER:

THIS IS TO CERTIFY THAT THE POLICIES OF INSURANCE LISTED BELOW HAVE BEEN ISSUED TO THE INSURED NAMED ABOVE FOR THE POLICY PERIOD INDICATED. NOTWITHSTANDING ANY REQUIREMENT, TERM OR CONDITION OF ANY CONTRACT OR OTHER DOCUMENT WITH RESPECT TO WHICH THIS CERTIFICATE MAY BE ISSUED OR MAY PERTAIN, THE INSURANCE AFFORDED BY THE POLICIES DESCRIBED HEREIN IS SUBJECT TO ALL THE TERMS, EXCLUSIONS AND CONDITIONS OF SUCH POLICIES. LIMITS SHOWN MAY HAVE BEEN REDUCED BY PAID CLAIMS.

Table with columns: INSR LTR, TYPE OF INSURANCE, ADDL SUBR INSR, WVD, POLICY NUMBER, POLICY EFF (MM/DD/YYYY), POLICY EXP (MM/DD/YYYY), LIMITS. Rows include Commercial General Liability, Automobile Liability, Umbrella Liab, Workers Compensation and Employers' Liability, and Inland Marine.

DESCRIPTION OF OPERATIONS / LOCATIONS / VEHICLES (ACORD 101, Additional Remarks Schedule, may be attached if more space is required) City of Lincoln, Nebraska; Lancaster County, Nebraska; Lincoln-Lancaster County Public Building Commission are named as Additional Insured in regards to the general liability and auto coverage. A Waiver of Subrogation applies to the General Liability and Workers Compensation policies.

CERTIFICATE HOLDER: City of Lincoln, Lancaster County, Lincoln-Lancaster County Public Building Commission, 555 S 10th, Lincoln, NE 68508. CANCELLATION: SHOULD ANY OF THE ABOVE DESCRIBED POLICIES BE CANCELLED BEFORE THE EXPIRATION DATE THEREOF, NOTICE WILL BE DELIVERED IN ACCORDANCE WITH THE POLICY PROVISIONS. AUTHORIZED REPRESENTATIVE: [Signature]

THIS ENDORSEMENT CHANGES THE POLICY. PLEASE READ IT CAREFULLY.

BLANKET ADDITIONAL INSURED — WHEN REQUIRED BY WRITTEN AGREEMENT

This endorsement modifies insurance provided under the following:

BUSINESSOWNERS COVERAGE FORM

Paragraph C. Who is an insured in Section II — Liability

- A.** Is amended to include as an additional insured any person or organization when you and such person or organization have agreed in writing in a contract or agreement that such person or organization be added as an additional insured on your policy. Such person or organization is an additional insured only with respect to liability for "bodily injury", "property damage" or "personal and advertising injury" caused, in whole or in part, by your acts or omissions or the acts or omissions or the acts or omissions of those acting on your behalf:
1. In the performance of your ongoing operations; or
 2. In connection with your premises owned or rented to you.
- B.** The limits of insurance applicable to the additional Insured are those specified in the Declarations of this Policy or in the written contract, whichever is lower. These limits of insurance are inclusive of and not in addition to the limits of insurance shown in the Declarations.
- C.** Any coverage provided hereunder shall be excess over any other valid and collectible insurance available to the additional insured whether that insurance is primary, excess, contingent or on any other basis, unless you and the additional insured have specifically agreed in a written contract or written agreement that this insurance be primary.
- When coverage is provided on a primary basis we will not seek contribution from any other insurance available to the additional insured if a written contract or written agreement requires that this insurance be noncontributory.
- D.** All other terms and conditions of this policy remain unchanged.

SCHEDULE OF FORMS AND ENDORSEMENTS

POLICY NUMBER: BBP0006866-00	EFFECTIVE DATE: 06/23/2019
--	--------------------------------------

<u>NUMBER</u>	<u>TITLE</u>
AH CI 8520 (12-18)	Commercial Insurance Policy Jacket
BP DS 01 (07-13)	Businessowners Policy Declarations
BP DS 01-S (07-13)	Supplemental Declarations Page
BP 00 03 (07-13)	Businessowners Coverage Form
BP IN 01 (07-13)	Businessowners Coverage Form Index
AH IL 8525 (09-17)	Fees And Surcharge Schedule
AH BP 80 04 (09-17)	Lead Liability Exclusion
AH BP 80 13 (09-17)	Businessowners Plus Endorsement
AH BP 80 54 (09-17)	Notice Of Terrorism Insurance Coverage
AH BP 80 57 (09-17)	Exclusion - Sunlamps And Tanning Beds
AH BP 80 58 (09-17)	Pollutants Definition Amendment
AH BP 80 73 (09-17)	Businessowners Enhancement Form
AH BP 80 84 (10-17)	Blanket Additional Insured - When Required By Written Agreement
AH BP 81 86 (09-17)	Asbestos Exclusion
AH BP 81 83 (09-17)	Nuclear, Biological, Chemical and Radiological Hazards Exclusion
AH BP 82 10 (09-17)	Equipment Breakdown Coverage
BP 01 12 (12-17)	Nebraska Changes
BP 04 02 (07-13)	Additional Insured - Managers Or Lessors Of Premises
BP 04 02 (07-13)	Additional Insured - Managers Or Lessors Of Premises
BP 04 17 (01-10)	Employment-related Practices Exclusion
BP 04 19 (07-13)	Amendment - Liquor Liability Exclusion - Exception For Scheduled Premises Or Activities
BP 04 39 (07-02)	Abuse or Molestation Exclusion
BP 04 41 (07-13)	Business Income Changes - Time Period
BP 04 50 (07-13)	Additional Insured - Owners, Lessees Or Contractors - Scheduled Person Or Organization
BP 04 52 (07-13)	Additional Insured - State Or Governmental Agency Or Subdivision Or Political Subdivisions - Permits Or Authorization
BP 04 83 (01-10)	Removal Of Insurance-to-value Provisions
BP 04 97 (01-06)	Waiver Of Transfer Of Rights Of Recovery Against Others To Us
BP 05 01 (07-02)	Calculation Of Premium
BP 05 15 (01-15)	Disclosure Pursuant To Terrorism Risk Insurance Act
BP 05 17 (01-06)	Exclusion - Silica Or Silica-Related Dust
BP 05 23 (01-15)	Cap On Losses From Certified Acts Of Terrorism
BP 05 38 (01-15)	Exclusion Of Other Acts Of Terrorism Committed Outside The United States; Cap On Losses From Certified Acts Of Terrorism
BP 05 42 (01-15)	Exclusion Of Punitive Damages Related To A Certified Act Of Terrorism
BP 05 77 (01-06)	Fungi Or Bacteria Exclusion (Liability)
BP 12 03 (01-10)	Loss Payable Clauses
BP 14 79 (07-13)	Specified Business Personal Property Temporarily Away From Premises

THIS ENDORSEMENT CHANGES THE POLICY. PLEASE READ IT CAREFULLY.

DESIGNATED INSURED FOR COVERED AUTOS LIABILITY COVERAGE

This endorsement modifies insurance provided under the following:

AUTO DEALERS COVERAGE FORM
BUSINESS AUTO COVERAGE FORM
MOTOR CARRIER COVERAGE FORM

With respect to coverage provided by this endorsement, the provisions of the Coverage Form apply unless modified by this endorsement.

This endorsement identifies person(s) or organization(s) who are "insureds" for Covered Autos Liability Coverage under the Who Is An Insured provision of the Coverage Form. This endorsement does not alter coverage provided in the Coverage Form.

This endorsement changes the policy effective on the inception date of the policy unless another date is indicated below.

Named Insured:	Office Interiors and Design Inc
Endorsement Effective Date:	06/23/2019

SCHEDULE

Name Of Person(s) Or Organization(s):
City of Lincoln and/or Lancaster County and/or City of Lincoln/Lancaster County Public Building Commission 555 S 10th St Lincoln, NE 68508
Information required to complete this Schedule, if not shown above, will be shown in the Declarations.

Each person or organization shown in the Schedule is an "insured" for Covered Autos Liability Coverage, but only to the extent that person or organization qualifies as an "insured" under the Who Is An Insured provision contained in Paragraph A.1. of Section II – Covered Autos Liability Coverage in the Business Auto and Motor Carrier Coverage Forms and Paragraph D.2. of Section I – Covered Autos Coverages of the Auto Dealers Coverage Form.

THIS ENDORSEMENT CHANGES THE POLICY. PLEASE READ IT CAREFULLY.

**WAIVER OF TRANSFER OF RIGHTS OF RECOVERY
AGAINST OTHERS TO US**

This endorsement modifies insurance provided under the following:

BUSINESSOWNERS COVERAGE FORM

SCHEDULE

Name Of Person Or Organization:
City of Lincoln Lancaster County and/or City of Lincoln/Lancaster County Public Building Commission 555 S 10th St Lincoln, NE 68508
Information required to complete this Schedule, if not shown above, will be shown in the Declarations.

Paragraph K. **Transfer Of Rights Of Recovery Against Others To Us** in **Section III – Common Policy Conditions** is amended by the addition of the following:

We waive any right of recovery we may have against the person or organization shown in the Schedule above because of payments we make for injury or damage arising out of your ongoing operations or "your work" done under a contract with that person or organization and included in the "products-completed operations hazard". This waiver applies only to the person or organization shown in the Schedule above.

SFM Safe Insurance Company
Workers' Compensation and Employers' Liability Policy

Waiver Of Our Right To Recover From Others Endorsement

This endorsement changes the policy to which it is attached effective on the inception date of the policy unless a different date is indicated below.

This endorsement, effective on **12/11/2018** at 12:01 A.M. standard time, forms a part of Policy **094137.202** issued to **Office Interiors and Design Inc.**

We have the right to recover our payments from anyone liable for an injury covered by this policy. We will not enforce our right against the person or organization named in the Schedule. (This agreement applies only to the extent that you perform work under a written contract that requires you to obtain this agreement from us.)

This agreement shall not operate directly or indirectly to benefit anyone not named in the Schedule.

SCHEDULE

This waiver of subrogation endorsement applies to the state of Nebraska and the City of Lincoln.

Blanket Waiver: The named insured agrees to waive all rights of subrogation against entities that have contractual requirements for such.