

Received Date
5/22/2019

LANCASTER COUNTY
555 SOUTH 10TH STREET
LINCOLN, NE 68508

Utility Permit No. 1811

Application Date
5/17/2019

Application to Construct
Utilities On County property

Project or WO No.

Contract No.

County Rep. AGO

Application is hereby made to LANCASTER COUNTY by:

Name: Jeremy Beck

Phone: 402-860-0869

Company Name: Unite Private Networks

E-Mail: jeremy.beck@upnfiber.com

Address: 3880 Vermaas Place

Lincoln, NE 68502

To construct a utility or utilities on County right-of-way as follows:

LEGAL DESCRIPTION:

NE 1/4 of Section 9, T8N, R7E, N 1/2 of Section 10, T8N, R7E, S 1/2 of Section 3, T8N, R7E, SW 1/4 of Section 2, T8N, R7E

UTILITY TO BE CONSTRUCTED

TYPE	DESCRIPTION	ANNOTATION
Communication	Cable, Coax, Fiber	

Other No utility to be buried directly above a drainage structure. Existing utilities will be separated by 24".

PROPOSED UTILITY INSTALLATION

METHOD	SIZE/WIDTH	DESCRIPTION	DEPTH	DESCRIPTION
Continuous Bore	Width	1.5"	Depth	48" MINIMUM
Open Trench	Width	1.5"	Depth	48" MINIMUM

Other Contact Ron Bohaty at 402-441-7797 48 hours prior to any construction in County Right-of-way.

NAME AND ADDRESS OF CONTRACTOR(S) PERFORMING THE WORK (if Applicable):

TH Construction 21651 Williams Circle
Gretna, NE 68028

UTILITY PERMIT REQUIREMENTS

NOTE – If Engineer plan sheet project notes conflict with Lancaster County’s utility permit application requirements and the special utility permit requirements, the utility permit application requirements and special utility permit requirements shall govern. **See Page 6 for additional requirements upon permit approval.**

1. Unless agreed to in writing in advance by the owner, the depth of installed facilities shall be at a minimum as follows:
 - A. For utility installation parallel to the roadway, the minimum depth of burial will be ~~42"~~ ^{48"} (48" in road ditches) measured from the ground surface to the top of the utility, except as noted in "C" below.
 - B. For utility installation transverse to the roadway the minimum depth of burial will be 48" measured from the ground surface to the top of the utility, except as noted in "C" below.
 - C. The minimum depth of burial beneath drainage structures, waterways, creek channels, or culverts within 5' of the utility route will be 72", measured from the flow line of the drainage structure, waterway, or creek channel (whichever is lower), to the top of the utility.
 - D. No utility will be buried directly above a drainage structure, **regardless of the burial depth.**
 - E. All crossings with existing utilities will be separated by a minimum of 24", both horizontally and vertically.
 - F. All paved road and paved driveway crossings will be dry-bored.
 - G. All areas disturbed by construction will be restored to their pre-construction condition. This includes: all open-cut crossings to be backfilled with material excavated from trench; no sand or crushed rock backfill will be allowed; and compaction of backfills to a density equal to or greater than the surrounding soil in and around trenches, bore pits, pull boxes, and other utility appurtenances. It also includes replacing roadway and driveway surfacing lost or damaged by construction, and re-seeding of all areas disturbed by the work.
 - H. Trees within the right-of-way will be preserved by the contractor when possible. All trees, bushes, brush, debris piles, resulting from clearing or grubbing operations will become the property of the contractor and will be removed from county property at the contractor’s expense.
2. The contractor performing the work shall have onsite a copy of approved utility permit allowing permitted work to be done within County Road Right-of-Way.
3. The utility owner or his representative will mark all existing Lancaster County drainage structures along the proposed utility installation route 24 hours prior to construction at a culvert site. All structures will be marked in a manner so as to allow the Utility’s Contractor to identify all "Bore" locations.
4. The contractor will notify Lancaster County Maintenance Superintendent ~~Bob Jacobs~~ ^{Ron Bohaty} at 402-441-7797, within 48 hours, prior to commencing construction on county right-of way.
5. Contractor performing the work to submit insurance certificate naming Lancaster County as additional insured prior to any activities in the right-of-way. Contractor shall also provide Lancaster County a 30 day notice of cancellation, non-renewal or any material reduction of insurance coverage.
6. The applicant, or his contractor, shall contact the local utility companies and request location of any buried utilities. Damage to any utilities, either on County right-of-way or adjacent to County right-of-way, shall be repaired at the expense of the applicant or his contractor.

7. Future road construction work could necessitate relocation of utilities. Those utility relocation costs shall be borne by the utility owner.
8. All trenches shall be backfilled the same day trench was excavated except for the portion where the work is to be continued the next day. The portion left open for work continuation shall be protected by barricades with flashing lights at night. No open trenches in the roadway will be allowed overnight. (Except when such road is closed for construction or except with prior conditional approval to be noted on page #6)
9. Roads may be closed for a maximum of 12 hours, with prior review and approval from this office. (See #11 for signage layout)
10. Road closures longer than 12 hours will require prior review and shall include an approved detour plan. (See #11 for signage layout)
11. Three Type III barricades w/Type A flashing lights shall be placed on each side of construction site. "Road Closed" {R 1 1-2} signs shall be mounted on the middle barricade on each side of the construction site. At the nearest intersection each way from crossing, a "Road Closed _____ Miles ahead -- Local Traffic Only" (R11-3) sign shall be placed.
12. All barricading, flagmen, warning signs, etc. shall conform to the current **Manual on Uniform Traffic Control Devices.**
13. No equipment shall be left unattended on public right-of-way. No trenches shall be left open after working hours. No equipment shall block traffic control devices. If necessary, flagmen shall be required.
14. All pipe and encasements to conform to State Highway Standards.
15. **Notification of proposed utility work to adjacent landowners shall be the responsibility of the Utility Company and or their Agents.**
16. *****Utility Company and or their Agents shall be responsible to notify the Lancaster County Engineering Department upon completion of permitted utility work.*****

TYPICAL CROSS SECTION OF ROAD CROSSING

(Proposed Drawing by Applicant)

I (We) agree to construct the Fiber Optic Cable in accordance with the permit requirements and
(utility)
the provisions included as a part of this permit.

COMPANY: Unite Private Networks

DATE: 5/17/2019

SIGNED BY: Jeremy Beck Digitally signed by Jeremy Beck
Date: 2019.05.17 13:16:20 -05'00'

EXECUTION BY LANCASTER COUNTY

The above application is hereby approved subject to the requirements and provisions of the permit.

APPROVED and dated this _____ day of _____ by the Lancaster County
Board of Commissioners.

LANCASTER COUNTY BOARD OF COMMISSIONERS

Chairperson

APPROVED as to form

this _____ day of _____

Deputy County Attorney

REVIEWED this _____ day of _____, _____

Lancaster County Engineering Representative

I (We) agree to construct the Fiber Optic Cable in accordance with the permit requirements and
(utility)
the provisions included as a part of this permit.

COMPANY: _____

DATE: 5/17/2019

SIGNED BY: _____

EXECUTION BY LANCASTER COUNTY

The above application is hereby approved subject to the requirements and provisions of the permit.

Date _____

Signed By: _____
Lancaster County Representative

This Page Intentionally Left Blank

(TO BE FILLED IN BY COUNTY PERSONNEL)

Encasement Requirements:

NA

Barricade, Signing and Flagging Requirements:

Comply with Section #12 of the Utility Permit Requirements.

Methods of Installation:

See Plans

Minimum Cover Provided in Road Ditches:

Comply with Section #1 of the Utility Permit Requirements

Other Requirements:

Comply with Section #2 of the Utility Permit Requirements: The Contractor is required to have a copy of the permit in-hand at all times while construction is in progress.

Comply with Section #4 of the Utility Permit Requirements: Contractor to contact Lancaster County Maintenance Superintendent Ron Bohaty (402) 441-7797 within 48-hours prior to beginning construction in the County Right-of-Way.

Additional Comments:

Comply with ALL Sections of the Utility Permit Requirements.

Utility Owners responsibility to notify Lancaster County upon completion of permitted work.

See notes on plans.

**INSURANCE CLAUSE
FOR LANCASTER COUNTY ENGINEER UTILITY PERMITS**

Insurance; Coverage Information

The contractor shall, prior to beginning work, provide proof of insurance coverage in a form satisfactory to the County, which shall not withhold approval unreasonably. The coverages and minimum levels required by this contract are set forth below and shall be in effect for all times that work is being done pursuant to this Contract. No work on the Project or pursuant to this Contract shall begin until all insurance obligations herein are met to the satisfaction of the County, which shall not unreasonably withhold approval. Self-insurance shall not be permitted unless consent is given by the County prior to execution of the Agreement and may require submission of financial information for analysis. Deductible levels shall be provided in writing from the Contractor's insurer and will be no more than \$25,000.00 per occurrence. Said insurance shall be written on an **OCCURRENCE** basis, and shall be **PRIMARY, with any insurance coverage maintained by the County being secondary or excess.**

Certificates

The Contractor shall provide certificates of insurance and endorsements evidencing compliance with these requirements. The Contractor shall provide a Certificate of Insurance demonstrating the coverage required herein and the necessary endorsements and waivers described herein and below before being permitted to begin the work or project. All certificates, endorsements and endorsement forms (where required) must be acceptable to the County Attorney. Certificates shall include an endorsement to provide for at least thirty (30) days' firm written notice in the event of cancellation. During the term of the Agreement and during the period of any required continuing coverages, the Contractor shall provide, prior to expiration of the policies, certificates and endorsement forms evidencing renewal insurance coverages. The parties agree that the failure of County to object to the form of a certificate and/or additional insured endorsement or endorsement forms provided shall not constitute a waiver of this requirement.

1. Commercial General Liability

The Contractor shall provide proof of Commercial General Liability Insurance with a minimum limit of not less than \$1,000,000.00 each occurrence and \$2,000,000.00 aggregate. These minimum limits can be met by primary and umbrella liability policies. Coverage shall include: Premises-Operations, Products/ Completed Operations, Contractual, Broad Form Property Damage, and Personal Injury. Such coverage shall be endorsed for the general aggregate to be on a **PER PROJECT** basis, and the contractor shall provide an additional insured endorsement acceptable to the County. The required insurance must include coverage for all projects and operations of Contractor or similar language that meets the approval of the County, which approval shall not be unreasonably withheld.

1.1 Additional Insured (Requires an Endorsement Form)

An Additional Insured Endorsement Form showing the County as additional Insured.

1.2 Automobile Liability

The Contractor shall provide proof of Automobile Liability coverage, which shall include: Owned, Hired and Non-Owned. Bodily Injury and Property Damage Combined Single Limit shall be at least \$1,000,000 Per Accident.

1.3 Intentionally Omitted

1.4. Workers' Compensation; Employers' Liability

The Contractor shall provide proof of workers' compensation insurance of not less than minimum statutory requirements under the laws of the State of Nebraska and any other applicable State. Employers' Liability coverage with limits of not less than \$500,000.00 each accident or injury shall be included. The Contractor shall provide the County with an endorsement for waiver of subrogation. The contractor shall also be responsible for ensuring that all subcontractors have workers' compensation insurance for their employees before and during the time any work is done pursuant to this Contract.

1.5 Intentionally Omitted

1.5.1 Intentionally Omitted

1.6 Intentionally Omitted

1.7 Intentionally Omitted

1.8 Railroad Contractual Liability Insurance (Required only if appropriate)

If work is to be performed within 50 feet of any railroad property and affecting any railroad bridge or trestle, tracks, road beds, tunnel, underpass or railroad crossing, the Contractor must provide an endorsement (ISO® form CG24170193 or newer) that removes or deletes any exception for such work in the Contractor's commercial general liability policy. Any endorsement not described herein shall be subject to the approval of the County Attorney.

1.8.1 Railroad Protective Liability (Required only if appropriate)

If work is to be performed within 50 feet of any railroad property and affecting any railroad bridge or trestle, tracks, road beds, tunnel, underpass or crossing or otherwise required by the Special Provisions or applicable requirements of an affected railroad, the Contractor shall provide Railroad Protective Liability Insurance naming the affected railroad/s as insured with minimum limits for bodily injury and property damage of \$2,000,000 per occurrence, \$6,000,000 aggregate, or such other limits as required in the Special Provisions or by the affected railroad. The original of the policy shall be furnished to the railroad and a certified copy of the same furnished to the County Purchasing Department prior to any related construction or entry upon railroad premises by the Contractor or for work related to the Contract.

1.9 Intentionally Omitted

2. Risk of Loss

Except to the extent covered by the builder's risk insurance, the Contractor shall have the sole responsibility for the proper storage and protection of, and assumes all risk of loss of, any Subcontractor's Work and tools, materials, equipment, supplies, facilities, offices and other property at or off the Project site. The Contractor shall be solely responsible for ensuring each subcontractor shall take every reasonable precaution in the protection of all structures, streets, sidewalks, materials and work of other subcontractors. Contractor shall protect its Work from damage by the elements or by other trades working in the area.

3. Umbrella or Excess Liability

The Contractor may use an Umbrella, Excess Liability, or similar coverage to supplement the primary insurance stated above in order to meet or exceed the minimum coverage levels required by this Contract.

4. Minimum Scope of Insurance

All Liability Insurance policies shall be written on an "Occurrence" basis only. All insurance coverage are to be placed with insurers authorized to do business in the State of Nebraska and must be placed with an insurer that has an A.M. Best's Rating of no less than A:VII unless specific approval has been granted otherwise.

5. Indemnification

To the fullest extent permitted by law the Contractor shall indemnify, defend, and hold harmless the County, its elected officials, officers, employees, agents, consultants, and employees of any of them from and against claims, damages, losses and expenses, including but not limited to attorney fees, arising out of or resulting from performance of the Work, provided that such claim, damage, loss or expense is attributable to bodily injury, sickness, disease or death, or to injury to or destruction of tangible or intangible property, including the Work itself, but only to the extent caused by the negligent, wrongful, or intentional acts or omissions of the Contractor, a subcontractor, anyone directly or indirectly employed by them or anyone for whose acts they may be liable, regardless of whether or not such claim, damage, loss or expense is caused in part by the negligence of a party indemnified hereunder. In the event the claim, damage, loss or expense is caused in part by the negligence of a party indemnified hereunder, the indemnification by the Contractor shall be prorated based on the extent of the liability of the party indemnified hereunder. Such obligation shall not be construed to negate, abridge, or reduce obligations of indemnity which would otherwise exist as to a party or person described in this Section. Nothing herein shall be construed to be a waiver of sovereign immunity by the County.

6. Reservation of Rights

The County reserves the right to require a higher limit of insurance or additional coverages when the County determines that a higher limit or additional coverage is required to protect the County or the interests of the public. Such changes in limits or coverages shall be eligible for a change order or amendment to the Contract.

7. Sovereign Immunity

Nothing contained in this clause or other clauses of this Agreement/Contract shall be construed to waive the Sovereign Immunity of the County.

For questions regarding Insurance Requirements, please contact Risk Management.

THIS CERTIFICATE IS ISSUED AS A MATTER OF INFORMATION ONLY AND CONFERS NO RIGHTS UPON THE CERTIFICATE HOLDER. THIS CERTIFICATE DOES NOT AFFIRMATIVELY OR NEGATIVELY AMEND, EXTEND OR ALTER THE COVERAGE AFFORDED BY THE POLICIES BELOW. THIS CERTIFICATE OF INSURANCE DOES NOT CONSTITUTE A CONTRACT BETWEEN THE ISSUING INSURER(S), AUTHORIZED REPRESENTATIVE OR PRODUCER, AND THE CERTIFICATE HOLDER.

IMPORTANT: If the certificate holder is an ADDITIONAL INSURED, the policy(ies) must have ADDITIONAL INSURED provisions or be endorsed. If SUBROGATION IS WAIVED, subject to the terms and conditions of the policy, certain policies may require an endorsement. A statement on this certificate does not confer any rights to the certificate holder in lieu of such endorsement(s).

PRODUCER INSPRO Insurance, Inc. 12702 Westport Parkway, Suite #301 LaVista, NE 68138 402 333-5700	CONTACT NAME: Kimberly Wirth PHONE (A/C, No, Ext): 402-333-5700	FAX (A/C, No): 402-333-0633	
	E-MAIL ADDRESS: kwirth@insproins.com		
INSURED TH Construction Company 21651 William Circle PO Box 686 Gretna, NE 68028	INSURER(S) AFFORDING COVERAGE		NAIC #
	INSURER A : Employers Mutual Insurance		21415
	INSURER B :		
	INSURER C :		
	INSURER D :		
	INSURER E :		

COVERAGES CERTIFICATE NUMBER: REVISION NUMBER:

THIS IS TO CERTIFY THAT THE POLICIES OF INSURANCE LISTED BELOW HAVE BEEN ISSUED TO THE INSURED NAMED ABOVE FOR THE POLICY PERIOD INDICATED. NOTWITHSTANDING ANY REQUIREMENT, TERM OR CONDITION OF ANY CONTRACT OR OTHER DOCUMENT WITH RESPECT TO WHICH THIS CERTIFICATE MAY BE ISSUED OR MAY PERTAIN, THE INSURANCE AFFORDED BY THE POLICIES DESCRIBED HEREIN IS SUBJECT TO ALL THE TERMS, EXCLUSIONS AND CONDITIONS OF SUCH POLICIES. LIMITS SHOWN MAY HAVE BEEN REDUCED BY PAID CLAIMS.

INSR LTR	TYPE OF INSURANCE	ADDL INSR	SUBR WVD	POLICY NUMBER	POLICY EFF (MM/DD/YYYY)	POLICY EXP (MM/DD/YYYY)	LIMITS
A	<input checked="" type="checkbox"/> COMMERCIAL GENERAL LIABILITY <input type="checkbox"/> CLAIMS-MADE <input checked="" type="checkbox"/> OCCUR <input checked="" type="checkbox"/> PD Ded:2,500 GEN'L AGGREGATE LIMIT APPLIES PER: <input type="checkbox"/> POLICY <input checked="" type="checkbox"/> PRO-JECT <input type="checkbox"/> LOC OTHER:	X	X	5D36921	11/10/2018	11/10/2019	EACH OCCURRENCE \$1,000,000 DAMAGE TO RENTED PREMISES (Ea occurrence) \$500,000 MED EXP (Any one person) \$10,000 PERSONAL & ADV INJURY \$1,000,000 GENERAL AGGREGATE \$2,000,000 PRODUCTS - COMP/OP AGG \$2,000,000 \$
A	<input checked="" type="checkbox"/> AUTOMOBILE LIABILITY <input checked="" type="checkbox"/> ANY AUTO OWNED AUTOS ONLY <input checked="" type="checkbox"/> HIRED AUTOS ONLY <input type="checkbox"/> SCHEDULED AUTOS <input checked="" type="checkbox"/> NON-OWNED AUTOS ONLY	X	X	5E36921	11/10/2018	11/10/2019	COMBINED SINGLE LIMIT (Ea accident) \$1,000,000 BODILY INJURY (Per person) \$ BODILY INJURY (Per accident) \$ PROPERTY DAMAGE (Per accident) \$ \$
A	<input checked="" type="checkbox"/> UMBRELLA LIAB <input checked="" type="checkbox"/> EXCESS LIAB <input type="checkbox"/> DED <input type="checkbox"/> RETENTION \$	X		5J36921	11/10/2018	11/10/2019	EACH OCCURRENCE \$10,000,000 AGGREGATE \$10,000,000 \$
A	<input checked="" type="checkbox"/> WORKERS COMPENSATION AND EMPLOYERS' LIABILITY ANY PROPRIETOR/PARTNER/EXECUTIVE OFFICER/MEMBER EXCLUDED? <input checked="" type="checkbox"/> Y <input type="checkbox"/> N (Mandatory in NH) If yes, describe under DESCRIPTION OF OPERATIONS below		X	5H36921	11/10/2018	11/10/2019	<input checked="" type="checkbox"/> PER STATUTE <input type="checkbox"/> OTH-ER E.L. EACH ACCIDENT \$500,000 E.L. DISEASE - EA EMPLOYEE \$500,000 E.L. DISEASE - POLICY LIMIT \$500,000

DESCRIPTION OF OPERATIONS / LOCATIONS / VEHICLES (ACORD 101, Additional Remarks Schedule, may be attached if more space is required)

** Supplemental Name **

TH Construction Company
TH Trailer Sales

Lancaster County is listed as additional insured on the General Liability as required by permit.

Waiver of Subrogation on the Workers Compensation in favor of Lancaster County. 30 day cancellation notice.

CERTIFICATE HOLDER

CANCELLATION

Lancaster County 555 South 10th Street Lincoln, NE 68508	SHOULD ANY OF THE ABOVE DESCRIBED POLICIES BE CANCELLED BEFORE THE EXPIRATION DATE THEREOF, NOTICE WILL BE DELIVERED IN ACCORDANCE WITH THE POLICY PROVISIONS. AUTHORIZED REPRESENTATIVE 
--	---

This page has been left blank intentionally.

THIS ENDORSEMENT CHANGES THE POLICY. PLEASE READ IT CAREFULLY.

**ADDITIONAL INSURED – STATE OR GOVERNMENTAL
AGENCY OR SUBDIVISION OR POLITICAL
SUBDIVISION – PERMITS OR AUTHORIZATIONS**

This endorsement modifies insurance provided under the following:

COMMERCIAL GENERAL LIABILITY COVERAGE PART

SCHEDULE

State Or Governmental Agency Or Subdivision Or Political Subdivision:

Lancaster County, NE

Information required to complete this Schedule, if not shown above, will be shown in the Declarations.

A. Section II – Who Is An Insured is amended to include as an additional insured any state or governmental agency or subdivision or political subdivision shown in the Schedule; subject to the following provisions:

1. This insurance applies only with respect to operations performed by you or on your behalf for which the state or governmental agency or subdivision or political subdivision has issued a permit or authorization.

However:

- a. The insurance afforded to such additional insured only applies to the extent permitted by law; and
- b. If coverage provided to the additional insured is required by a contract or agreement, the insurance afforded to such additional insured will not be broader than that which you are required by the contract or agreement to provide for such additional insured.

2. This insurance does not apply to:

- a. "Bodily injury", "property damage" or "personal and advertising injury" arising out of operations performed for the federal government, state or municipality; or
- b. "Bodily injury" or "property damage" included within the "products-completed operations hazard".

B. With respect to the insurance afforded to these additional insureds, the following is added to Section III – Limits Of Insurance:

If coverage provided to the additional insured is required by a contract or agreement, the most we will pay on behalf of the additional insured is the amount of insurance:

- 1. Required by the contract or agreement; or
- 2. Available under the applicable Limits of Insurance shown in the Declarations;

whichever is less.

This endorsement shall not increase the applicable Limits of Insurance shown in the Declarations.

WAIVER OF OUR RIGHT TO RECOVER FROM OTHERS ENDORSEMENT

We have the right to recover our payments from anyone liable for an injury covered by this policy. We will not enforce our right against the person or organization named in the Schedule. (This agreement applies only to the extent that you perform work under a written contract that requires you to obtain this agreement from us.)

This agreement shall not operate directly or indirectly to benefit anyone not named in the Schedule.

Schedule

**ANY OR ALL PERSONS OR ORGANIZATIONS SUBJECT TO A WRITTEN CONTRACT
REQUIRING SUCH A WAIVER AGREEMENT**

This endorsement changes the policy to which it is attached and is effective on the date issued unless otherwise stated.

(The information below is required only when this endorsement is issued subsequent to preparation of the policy.)

Endorsement
Insured **TH Construction Company**
Insurance Company
EMC

Effective Policy No.
5H36921

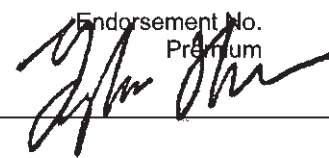
Endorsement No.
Premium

Countersigned by _____

THIS ENDORSEMENT CHANGES THE POLICY. PLEASE READ IT CAREFULLY.

COMMERCIAL AUTO ELITE EXTENSION

This endorsement modifies insurance provided under the following:

BUSINESS AUTO COVERAGE FORM

POLICY #5E36921

The BUSINESS AUTO COVERAGE FORM is amended to include the following clarifications and extensions of coverage. With respect to coverage provided by this endorsement, the provisions of the Coverage Form apply unless modified by the endorsement.

A. TEMPORARY SUBSTITUTE AUTO PHYSICAL DAMAGE

Section I – Covered Autos Paragraph **C. Certain Trailers, Mobile Equipment, and Temporary Substitute Autos** is amended by adding the following:

If **Physical Damage Coverage** is provided by this coverage form for an "auto" you own, the **Physical Damage Coverages** provided for that owned "auto" are extended to any "auto" you do not own while used with the permission of its owner as a temporary substitute for the covered "auto" you own that is out of service because of breakdown, repair, servicing, "loss" or destruction.

The coverage provided is the same as the coverage provided for the vehicle being replaced.

B. BLANKET ADDITIONAL INSURED

Section II – Covered Autos Liability Coverage, A.1. Who Is An Insured is amended by adding the following:

Any person or organization who is a party to a written agreement or contract with you in which you agree to provide the type of insurance afforded under this Business Auto Coverage Form.

This provision applies to claims for "bodily injury" or "property damage" which occur after the execution of any written agreement or contract.

C. EMPLOYEES AS INSURED

The following is added to the **Section II – Covered Autos Liability Coverage, Paragraph A.1. Who Is An Insured** Provision:

Any "employee" of yours is an "insured" while using a covered "auto" you don't own, hire or borrow in your business or your personal affairs.

D. EMPLOYEE HIRED AUTOS

1. Changes In Covered Autos Liability Coverage

The following is added to the **Who Is An Insured** Provision:

An "employee" of yours is an "insured" while operating an "auto" hired or rented under a contract or agreement in an "employee's" name, with your permission, while performing duties related to the conduct of your business.

2. Changes In General Conditions

Paragraph **5.b.** of the **Other Insurance** Condition in the Business Auto Coverage Form is replaced by the following:

For Hired Auto Physical Damage Coverage, the following are deemed to be covered "autos" you own:

- a. Any covered "auto" you lease, hire, rent or borrow; and
- b. Any covered "auto" hired or rented by your "employee" under a contract in an "employee's" name, with your permission, while performing duties related to the conduct of your business.

However, any "auto" that is leased, hired, rented or borrowed with a driver is not a covered "auto".

E. NEWLY FORMED OR ACQUIRED ORGANIZATIONS

Section II – Covered Autos Liability Coverage, A.1. Who Is An Insured is amended by adding the following:

Any organization which you acquire or form after the effective date of this policy in which you maintain ownership or majority interest. However:

- (1) Coverage under this provision is afforded only up to 180 days after you acquire or form the organization, or to the end of the policy period, whichever is earlier.
- (2) Any organization you acquire or form will not be considered an "insured" if:
 - (a) The organization is a partnership or a joint venture; or
 - (b) That organization is covered under other similar insurance.
- (3) Coverage under this provision does not apply to any claim for "bodily injury" or "property damage" resulting from an "accident" that occurred before you formed or acquired the organization.

F. SUBSIDIARIES AS INSURED

Section II – Covered Autos Liability Coverage, A.1. Who Is An Insured is amended by adding the following:

Any legally incorporated subsidiary in which you own more than 50% of the voting stock on the effective date of this policy. However, "insured" does not include any subsidiary that is an "insured" under any other automobile liability policy or was an "insured" under such a policy but for termination of that policy or the exhaustion of the policy's limits of liability.

G. SUPPLEMENTARY PAYMENTS

Section II – Covered Autos Liability Coverage, A.2.a. Coverage Extensions, Supplementary Payments (2) and (4) are replaced by the following:

- (2) Up to \$5,000 for cost of bail bonds (including bonds for related traffic law violations) required because of an "accident" we cover. We do not have to furnish these bonds.
- (4) All reasonable expenses incurred by the "insured" at our request, including actual loss of earnings up to \$500 a day because of time off from work.

H. FELLOW EMPLOYEE COVERAGE

In those jurisdictions where, by law, fellow employees are not entitled to the protection afforded to the employer by workers compensation exclusivity rule, or similar protection. The following provision is added:

Subparagraph 5. of Paragraph B. Exclusions in **Section II Covered Autos Liability Coverage** does not apply if the "bodily injury" results from the use of a covered "auto" you own or hire.

I. TOWING

Section III – Physical Damage Coverage, A.2. Towing is replaced with the following:

We will pay for towing and labor costs incurred, subject to the following:

- a. Up to \$100 each time a covered "auto" of the private passenger type is disabled; or
- b. Up to \$500 each time a covered "auto" other than the private passenger type is disabled.

However, the labor must be performed at the place of disablement.

J. LOCKSMITH SERVICES

Section III – Physical Damage Coverage, A.4. Coverage Extensions is amended by adding the following:

We will pay up to \$250 per occurrence for necessary locksmith services for keys locked inside a covered private passenger "auto". The deductible is waived for these services.

K. TRANSPORTATION EXPENSES

Section III – Physical Damage Coverage, A.4. Coverage Extensions Subparagraph a. Transportation Expenses is replaced by the following:

- (1) We will pay up to \$75 per day to a maximum of \$2,500 for temporary transportation expense incurred by you because of the total theft of a covered "auto" of the private passenger type. We will pay only for those covered "autos" for which you carry either Comprehensive or Specified Cause Of Loss Coverage. We will pay for temporary transportation expenses incurred during the period beginning 48 hours after the theft and ending, regardless of the policy's expirations, when the covered "auto" is returned to use or we pay for its "loss".
- (2) If the temporary transportation expenses you incur arise from your rental of an "auto" of the private passenger type, the most we will pay is the amount it costs to rent an "auto" of the private passenger type which is of the same like kind and quality as the stolen covered "auto".

L. AUDIO, VISUAL, AND DATA ELECTRONIC EQUIPMENT COVERAGE ADDED LIMITS

Audio, Visual, And Data Electronic Equipment Coverage Added Limits of \$5,000 Per "Loss" are in addition to the sublimit in Paragraph C.1.b. of the **Limits Of Insurance** provision under **Section III – Physical Damage Coverage**.

M. HIRED AUTO PHYSICAL DAMAGE

Section III – Physical Damage Coverage, A.4. Coverage Extensions is amended by adding the following:

If hired "autos" are covered "autos" for Liability Coverage, and if Comprehensive, Specified Causes of Loss, or Collision coverage is provided for any "auto" you own, then the Physical Damage coverages provided are extended to "autos" you hire, subject to the following limit and deductible:

- (1) The most we will pay for loss to any hired "auto" is the lesser of Actual Cash Value or Cost of Repair, minus the deductible.
- (2) The deductible will be equal to the largest deductible applicable to any owned "auto" for that coverage. No deductible applies to "loss" caused by fire or lightning.
- (3) Subject to the above limit and deductible provisions, we will provide coverage equal to the broadest coverage applicable to any covered "auto" you own.

We will pay up to \$1,000, in addition to the limit above, for loss of use of a hired auto to a leasing or rental concern for a monetary loss sustained, provided it results from an "accident" for which you are legally liable.

N. AUTO LOAN OR LEASE COVERAGE

Section III – Physical Damage Coverage
Paragraph **A.4. Coverage Extensions** is amended by the addition of the following:

In the event of a total "loss" to a covered "auto" which is covered under this policy for Comprehensive, Specified Cause of Loss, or Collision coverage, we will pay any unpaid amount due, including up to a maximum of \$500 for early termination fees or penalties, on the lease or loan for a covered "auto", less:

1. The amount paid under the **Physical Damage Coverage Section** of the policy; and
2. Any:
 - a. Overdue lease/loan payments at the time of the "loss";
 - b. Financial penalties imposed under a lease for excessive use, abnormal wear and tear or high mileage;
 - c. Security deposits not returned by the lessor;
 - d. Costs for extended warranties, Credit Life Insurance, Health, Accident or Disability Insurance purchased with the loan or lease; and
 - e. Carry-over balances from previous loans or leases.

Coverage does not apply to any unpaid amount due on a loan for which the covered "auto" is not the sole collateral.

O. PERSONAL PROPERTY OF OTHERS

Section III – Physical Damage Coverage, A.4. Coverage Extensions is amended by adding the following:

We will pay up to \$500 for loss to personal property of others in or on your covered "auto."

This coverage applies only in the event of "loss" to your covered "auto" caused by fire, lightning, explosion, theft, mischief or vandalism, the covered "auto's" collision with another object, or the covered "auto's" overturn.

No deductibles apply to this coverage.

P. PERSONAL EFFECTS COVERAGE

Section III – Physical Damage Coverage, A.4. Coverage Extensions is amended by adding the following:

We will pay up to \$500 for "loss" to your personal effects not otherwise covered in the policy or, if you are an individual, the personal effects of a family member, that is in the covered auto at the time of the "loss".

For the purposes of this extension personal effects means tangible property that is worn or carried by an insured including portable audio, visual, or electronic devices. Personal effects does not include tools, jewelry, guns, money and securities, or musical instruments

Q. EXTRA EXPENSE FOR STOLEN AUTO

Section III – Physical Damage Coverage, A.4. Coverage Extensions is amended by adding the following:

We will pay up to \$1,000 for the expense incurred returning a stolen covered "auto" to you because of the total theft of such covered "auto". Coverage applies only to those covered "autos" for which you carry Comprehensive or Specified Causes Of Loss Coverage.

R. RENTAL REIMBURSEMENT

Section III – Physical Damage Coverage, A.4. Coverage Extensions is amended by adding the following:

1. This coverage applies only to a covered "auto" for which **Physical Damage Coverage** is provided on this policy.
2. We will pay for rental reimbursement expenses incurred by you for the rental of an "auto" because of "loss" to a covered "auto". Payment applies in addition to the otherwise applicable amount of each coverage you have on a covered "auto". No deductibles apply to this coverage.
3. We will pay only for those expenses incurred during the policy period beginning 24 hours after the "loss" and ending, regardless of the policy's expiration, with the lesser of the following number of days.
 - a. The number of days reasonably required to repair or replace the covered "auto". If "loss" is caused by theft, this number of days is added to the number of days it takes to locate the covered "auto" and return it to you; or
 - b. 30 days.
4. Our payment is limited to the lesser of the following amounts:
 - a. Necessary and actual expenses incurred; or
 - b. \$75 per day, subject to a \$2,250 limit.
5. This coverage does not apply while there are spare or reserve "autos" available to you for your operations.
6. If "loss" results from the total theft of a covered "auto" of the private passenger type, we will pay under this coverage only that amount of your rental reimbursement expenses which is not already provided for under the Physical Damage – Transportation Expense Coverage Extension included in this endorsement.
7. Coverage provided by this extension is excess over any other collectible insurance and/or endorsement to this policy.

S. AIRBAG COVERAGE

Section III – Physical Damage Coverage, B.3.a. Exclusions is amended by adding the following:

If you have purchased Comprehensive or Collision Coverage under this policy, the exclusion relating to mechanical breakdown does not apply to the accidental discharge of an airbag.

T. NEW VEHICLE REPLACEMENT COST

The following is added to Paragraph C. **Limit Of Insurance** of **Section III – Physical Damage Coverage**

In the event of a total "loss" to your new covered auto of the private passenger type or vehicle having a gross vehicle weight of 20,000 pounds or less, to which this coverage applies, we will pay at your option:

- a. The verifiable new vehicle purchase price you paid for your damaged vehicle, not including any insurance or warranties.
- b. The purchase price, as negotiated by us, of a new vehicle of the same make, model, and equipment, or most similar model available, not including any furnishings, parts, or equipment not installed by the manufacturer or their dealership.
- c. The market value of your damaged vehicle, not including any furnishings, parts, or equipment not installed by the manufacturer or their dealership.

We will not pay for initiation or set up costs associated with a loans or leases.

For the purposes of this coverage extension a new covered auto is defined as an "auto" of which you are the original owner that has not been previously titled which you purchased less than 180 days prior to the date of loss.

U. LOSS TO TWO OR MORE COVERED AUTOS FROM ONE ACCIDENT

Section III – Physical Damage Coverage, D. Deductible is amended by adding the following:

If a Comprehensive, Specified Causes of Loss or Collision Coverage "loss" from one "accident" involves two or more covered "autos", only the highest deductible applicable to those coverages will be applied to the "accident".

If the application of the highest deductible is less favorable or more restrictive to the insured than the separate deductibles as applied in the standard form, the standard deductibles will apply.

This provision only applies if you carry Comprehensive, Collision or Specified Causes of Loss Coverage for those vehicles, and does not extend coverage to any covered "autos" for which you do not carry such coverage.

V. WAIVER OF DEDUCTIBLE – GLASS REPAIR OR REPLACEMENT

Section III – Physical Damage Coverage, D. Deductible is amended by adding the following:

If a Comprehensive Coverage deductible is shown in the Declarations it does not apply to the cost of repairing or replacing damaged glass.

W. DUTIES IN THE EVENT OF ACCIDENT, CLAIM, SUIT, OR LOSS

Section IV – Business Auto Conditions, A.2. Duties In The Event Of Accident, Claim, Suit Or Loss is amended by adding the following:

Your obligation to notify us promptly of an "accident", claim, "suit" or "loss" is satisfied if you send us the required notice as soon as practicable after your Insurance Administrator or anyone else designated by you to be responsible for insurance matters is notified, or in any manner made aware, of an "accident", claim, "suit" or "loss".

X. WAIVER OF TRANSFER OF RIGHTS OF RECOVERY

Subparagraph 5. of Paragraph A. **Loss Conditions** of **Section IV Business Auto Conditions** is deleted in its entirety and replaced with the following.

Transfer Of Rights Of Recovery Against Others To Us

If any person or organization to or for whom we make payment under this Coverage Form has rights to recover damages from another, those rights are transferred to us. That person or organization must do everything necessary to secure our rights and must do nothing after "accident" or "loss" to impair them.

However, we waive any right of recovery we may have against any person, or organization with whom you have a written contract, agreement or permit executed prior to the "loss" that requires a waiver of recovery for payments made for damages arising out of your operations done under contract with such person or organization.

Y. UNINTENTIONAL FAILURE TO DISCLOSE EXPOSURES

Section IV – Business Auto Conditions, B.2. Concealment, Misrepresentation, Or Fraud is amended by adding the following:

If you unintentionally fail to disclose any exposures existing at the inception date of this policy, we will not deny coverage under this Coverage Form solely because of such failure to disclose. However, this provision does not affect our right to collect additional premium or exercise our right of cancellation or non-renewal.

Z. MENTAL ANGUISH

Section V – Definitions, C. is replaced by the following:

"Bodily injury" means bodily injury, sickness or disease sustained by a person, including mental anguish or death resulting from bodily injury, sickness or disease.

AA. LIBERALIZATION

If we revise this endorsement to provide greater coverage without additional premium charge, we will automatically provide the additional coverage to all endorsement holders as of the day the revision is effective in your state.

PROJECT NO. 017-0140	SHEET NO. C.1
Date: 05/21/2019	Drawn: TMR Checked: STS Approved: JPD

PROJECT: 21830-82ND & BENNET ROAD MOVE

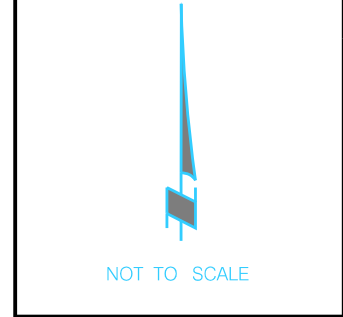

PRIOR TO CONSTRUCTION:

CALL 811 FOR LOCATION OF UNDERGROUND TELEPHONE, ELECTRIC, GAS MAINS, CABLE TELEVISION AND OTHER UTILITIES.

EXISTING UNDERGROUND AND OVERHEAD UTILITIES AND DRAINAGE STRUCTURES HAVE BEEN PLOTTED FROM AVAILABLE INFORMATION AND THEREFORE, THEIR LOCATIONS MUST BE CONSIDERED APPROXIMATE ONLY. IT IS THE RESPONSIBILITY OF THE INDIVIDUAL CONTRACTORS TO EXACTLY LOCATE AND PROTECT EACH EXISTING UTILITY BEFORE AND DURING ACTUAL CONSTRUCTION.

CONSTRUCTION SHALL MEET LANCASTER COUNTY STANDARD CONSTRUCTION SPECIFICATIONS AND STANDARD PLANS.

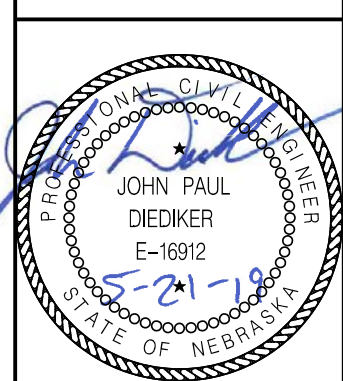

COVER

PROJECT COORDINATION CONTACTS			
NAME	AGENCY	PHONE NUMBER	EMAIL
JEREMY BECK	UNITE PRIVATE NETWORKS	402-860-0869	JEREMY.BECK@UPNFIBER.COM
ALEX OLSON	LANCASTER COUNTY	402-441-8328	AOLSON@LANCASTER.NE.GOV
JERRY ENNS	NORRIS PPD	402-228-2827	JERRYENN@NORRISPOWER.COM

LANCASTER COUNTY, NEBRASKA

UNITE PRIVATE NETWORKS

82ND AND BENNET ROAD MOVE

PERMITS REQUIRED	
SHT. NO.	DESCRIPTION
F.1-F.7	LANCASTER COUNTY
F.1	NORRIS PPD
F.6	FLOODPLAIN

SHEET INDEX	
SHT. NO.	SHEET INDEX
C.1	COVER
G.1	GENERAL NOTES
F.1-F.7	FIBER DESIGN

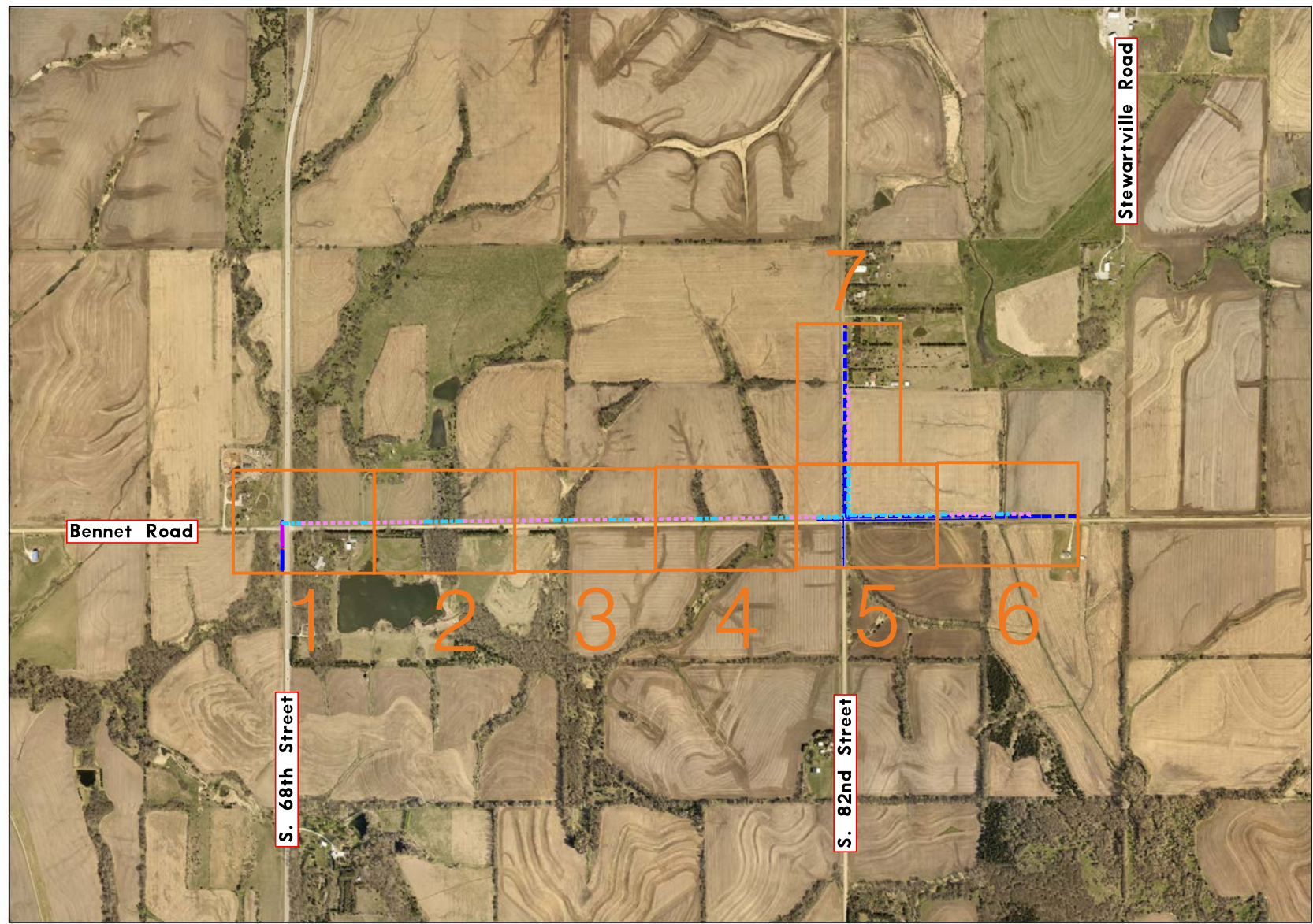

USER: field
 DATE: 05/21/2019
 DGN: F:\2017\0001-0500\017-0140-21830-82nd & Bennet Road Move\10-Design\Microstation\Telecom_LNK\017-0140_21830_82nd & Bennet Road Move\Sheets\Cover.dgn

USER: field DATE: 05/21/2019 DGN: F:\2017\0001-0500\017-0140-21830-82nd & Bennet Road Move\10-Design\Microstation\Telecom_LNK_017-0140_21830_82nd & Bennet Road Move_Sheets\GN_City of Lincoln_Master.dgn

LEGEND OF SYMBOLS

- EXISTING CONDUIT
- EXISTING AERIAL FIBER
- BORED CONDUIT
- TRENCHED CONDUIT
- NEW AERIAL FIBER
- NEW AERIAL FIBER, OVERLASH
- MESSENGER CABLE
- NEW PULL BOX
- NEW PEDESTAL
- NEW POLE
- NEW DOWN GUY
- NEW RISER
- NEW SLACK SPAN
- NEW SLACK LOOP
- EXISTING PULL BOX
- EXISTING PEDESTAL
- EXISTING UTILITY POLE
- EXISTING SLACK LOOP
- EXISTING SPLICE CASE
- EXISTING MANHOLE
- SIGN
- BARRICADE
- DRUM
- BORE PIT
- ARROW PANEL

CABLE AND CONDUIT DESIGNATIONS

- B is Conduit Bored (ie..3" B)
- C is conductor (ie.. 3/C)
- CC is Coaxial Cable
- CCC is Camera Control Cable
- CDC is Camera Detector Cable
- CG is Circuit Ground
- CPC is Camera Power Cable
- DB is Direct Buried
- DMSC is Dynamic Message Sign Cable
- EDC is Emergency Detector Cable
- ETW is Electric Tracer Wire
- EX is Existing
- FI is Fabric Interduct
- FLC is Fiber Locate Cable
- FTW is Fiber Tracer Wire
- INS is Install
- INT is Intraduct
- LC is Lead-In Cable
- M is Conduit Mounted (ie..2" M)
- 4-MB is Main Line Conduit Group Bored (4) 1 1/4"
- MM is Multi Mode Fiber Cable
- 4-MT is Main Line Conduit Group Trenched (4) 1 1/4"
- NO is Number
- OH is Over Head
- PR is Pair of Communication (ie.. 6 PR)
- REL is Relocate
- REM is Remove
- SC is Service Cable
- SL is Street Light
- SM is Single Mode Fiber Cable
- T is Conduit Trenched (ie..3" T)
- TW is Tracer Wire (black or green)

PCA243636-00006

POLYMER CONCRETE ASSEMBLY

24" x 36" x 36"
(For actual dimensions see drawing)
Polymer Concrete Assembly, Straight Sides, No Floor, WUC 3.6-20K, 3/8" Hex Bolts, Standard Nameplate (Specify at time of order) Installed

LOAD RATINGS
Incidental Traffic - Parking Lot, Sidewalk
Conforms to:
• WUC 3.6
• ASTM C 857
• ANSI/SCTE 77

FEATURES:
• USDA/RUS Approved
• Drop-In nameplate
• Shipped assembled
• Skid resistant cover
• Stainless steel bolts
• Cast-in floating nut box
• Integral drain holes

Additional product information continued on the reverse



2626 Kansas Avenue
Riverside, California 92507
951.787.0600
951.787.0632 (fax)
info@newbasis.com
newbasis.com

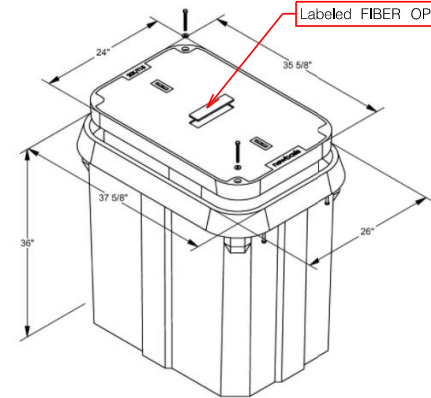

Inside Dimensions		
Length	Width	Depth
33 9/16"	21 15/16"	33"

REV: A.1

UPN PULL BOX, 24"X36"X36"

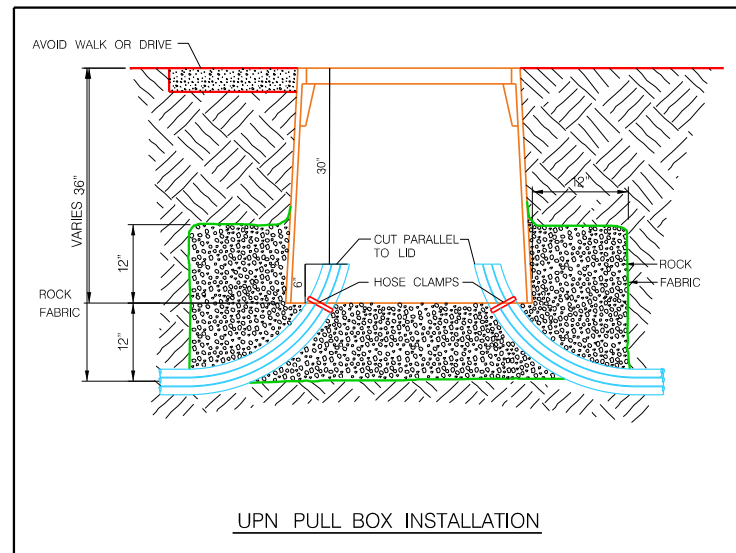

UPN PULL BOX INSTALLATION

SUMMARY OF QUANTITIES

ITEM	UNIT	QUANTITY
TRAFFIC CONTROL FOR CONSTRUCTION	LS.	1
CONDUIT, 1.5" B	LF.	3,333
CONDUIT, 1.5" T	LF.	4,995
TRACER WIRE	LF.	8,312
UPN PULL BOX	EA.	7
FIBER, 144 SM, UNDERGROUND	LF.	8,312
FIBER, 144 SM, UNDERGROUND SLACK STORAGE	LF.	560
FIBER, 144 SM, AERIAL	LF.	287
FIBER, 144 SM, AERIAL SLACK STORAGE	LF.	100
RISER	EA.	1

PROJECT NOTES

- THE LOCATIONS OF ALL AERIAL AND UNDERGROUND UTILITY FACILITIES MAY NOT BE INDICATED ON THESE PLANS. UNDERGROUND UTILITIES, WHETHER SHOWN OR NOT, WILL BE LOCATED AND FLAGGED BY THE UTILITIES UPON THE REQUEST OF THE CONTRACTOR. NO EXCAVATION WILL BE PERMITTED IN THE AREA OF THE UNDERGROUND UTILITIES UNTIL ALL SUCH FACILITIES HAVE BEEN LOCATED AND IDENTIFIED TO THE SATISFACTION OF ALL PARTIES. THE CONTRACTOR SHALL BE RESPONSIBLE FOR PROTECTION OF ALL UNDERGROUND AND AERIAL UTILITIES AND CONSTRUCTIONS.
- UNLESS AGREED TO IN WRITING IN ADVANCE BY THE CITY, THE DEPTH OF INSTALLED FACILITIES SHALL BE, AT A MINIMUM, AS FOLLOWS:
 - ~~FORTY-TWO (42) INCHES IN SOIL,~~
Forty-Eight (48) Inches in Soil
 - ~~FORTY-TWO (42) INCHES BELOW A PROJECTED SLOPE FROM THE FLOW LINE OF A DITCH AT A THREE (3) HORIZONTAL AND ONE (1) VERTICAL SLOPE,~~
Forty-Eight (48) Inches
 - FORTY-EIGHT (48) INCHES UNDER A ROADWAY MEASURED FROM THE SURFACE OF SAID ROADWAY TO THE TOP OF THE INSTALLATION,
 - SEVENTY-TWO (72) INCHES UNDER A STORM WATER OR CREEK CHANNEL DESIGN FLOW LINE, AND
 - MAINTAIN A MINIMUM OF 24" OF VERTICAL & HORIZONTAL SPACING FROM EXISTING UTILITIES.
- ALL POTHoles IN SIDEWALK PANELS WILL REQUIRE FULL PANEL REPLACEMENT.
- ANY CUT OR POTHOLE IN A CONCRETE STREETS PANEL WILL REQUIRE FULL PANEL REPLACEMENT.
- ANY CUT OR POTHOLE IN A ASPHALT STREET LANE WILL REQUIRE SEAM TO SEAM ASPHALT MILLING AND REPLACEMENT.

AERIAL FIBER INSTALLATION

- INSTALL THE MESSENGER WITH CABLES TO SPECIFIED SAG AS SUBMITTED ON COMM-SCOPE SAG DATA.
- FIELD VERIFY ALL NEWLY INSTALLED CABLE/MESSENGER CLEARANCES ARE CONSTRUCTED IN ACCORDANCE WITH THE NESC.
- ALL ABANDONED BOLT HOLES ARE TO BE TREATED WITH WOOD PRESERVER AND PLUGGED WITH SIMILAR MATERIALS AS STATED IN THE CONTRACT.
- GROUNDING TO BE INSTALLED AS STATED IN THE CONTRACT.

PROJECT NO. SHEET NO.

017-0140 G.1

Date: 05/21/2019 Drawn: TMR
Checked: STS
Approved: JPD

PROJECT: 21830-82ND & BENNET ROAD MOVE

olsson



PRIOR TO CONSTRUCTION:

CALL 811 FOR LOCATION OF UNDERGROUND TELEPHONE, ELECTRIC, GAS MAINS, CABLE TELEVISION AND OTHER UTILITIES.

EXISTING UNDERGROUND AND OVERHEAD UTILITIES AND DRAINAGE STRUCTURES HAVE BEEN PLOTTED FROM AVAILABLE INFORMATION AND THEREFORE, THEIR LOCATIONS MUST BE CONSIDERED APPROXIMATE ONLY. IT IS THE RESPONSIBILITY OF THE INDIVIDUAL CONTRACTORS TO EXACTLY LOCATE AND PROTECT EACH EXISTING UTILITY BEFORE AND DURING ACTUAL CONSTRUCTION.

CONSTRUCTION SHALL MEET LANCASTER COUNTY STANDARD CONSTRUCTION SPECIFICATIONS AND STANDARD PLANS.

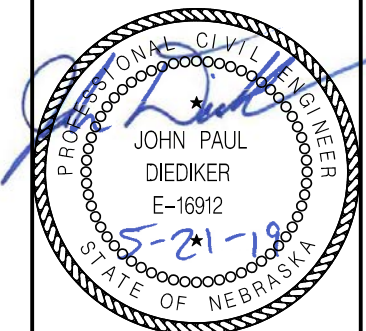

GENERAL NOTES

USER: field
 DATE: 05/21/2019
 DGN: F:\2017\0001-0500\017-0140-21830-82nd & Bennet Road Move\Telecom_LNK\017-0140_21830_82nd & Bennet Road Move\Sheets\F.1.dgn

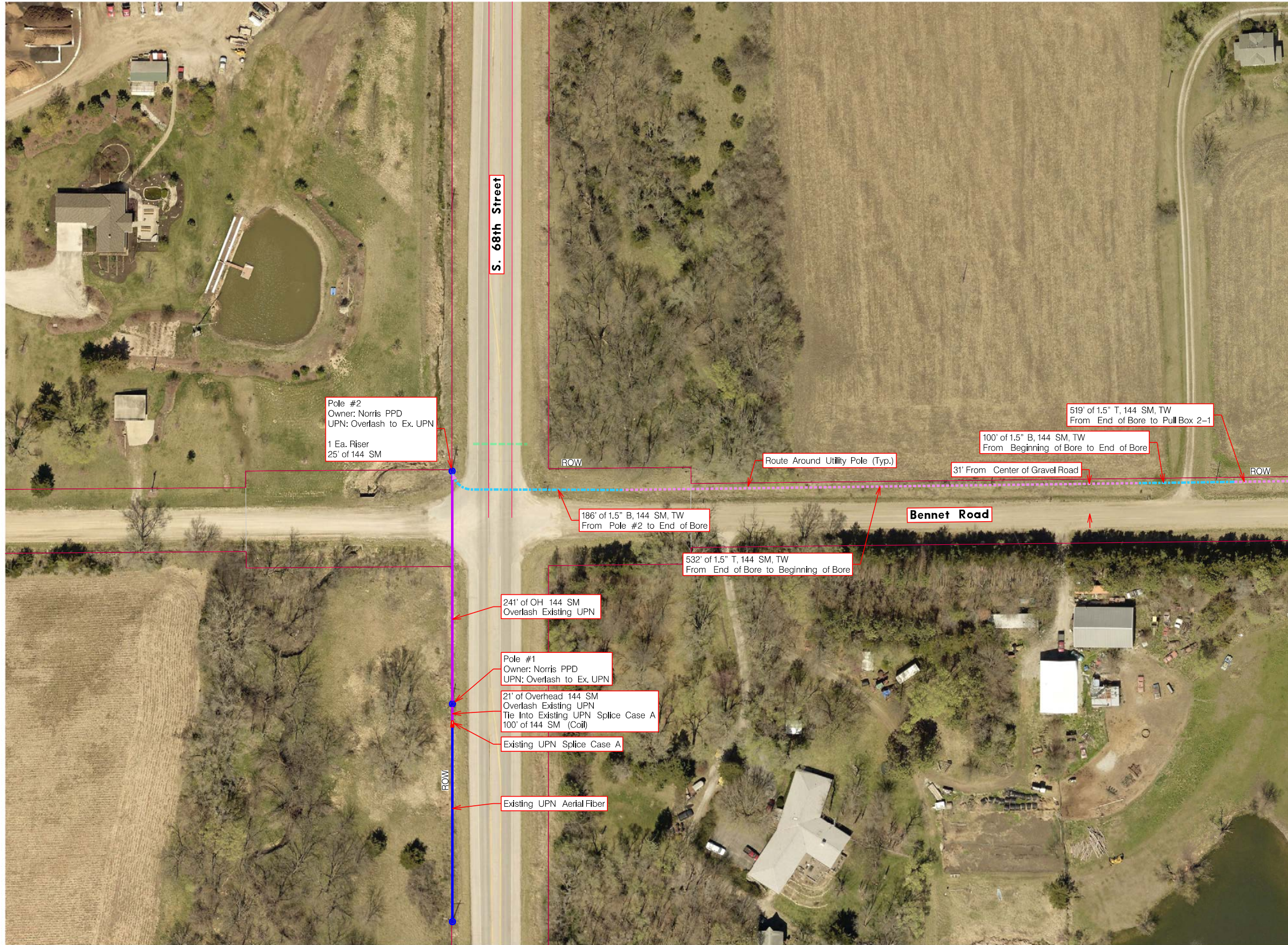

PROJECT NO.	SHEET NO.
017-0140	F.1
Date: 05/21/2019	Drawn: TMR
	Checked: STS
Horz. Scale 1 : 100	Approved: JPD

PROJECT: 21830-82ND & BENNET ROAD MOVE

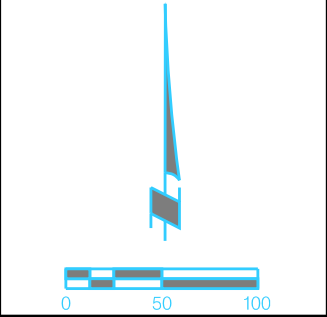

MATCH LINE SHEET F.2

PRIOR TO CONSTRUCTION:

CALL 811 FOR LOCATION OF UNDERGROUND TELEPHONE, ELECTRIC, GAS MAINS, CABLE TELEVISION AND OTHER UTILITIES.

EXISTING UNDERGROUND AND OVERHEAD UTILITIES AND DRAINAGE STRUCTURES HAVE BEEN PLOTTED FROM AVAILABLE INFORMATION AND THEREFORE, THEIR LOCATIONS MUST BE CONSIDERED APPROXIMATE ONLY. IT IS THE RESPONSIBILITY OF THE INDIVIDUAL CONTRACTORS TO EXACTLY LOCATE AND PROTECT EACH EXISTING UTILITY BEFORE AND DURING ACTUAL CONSTRUCTION.

CONSTRUCTION SHALL MEET LANCASTER COUNTY STANDARD CONSTRUCTION SPECIFICATIONS AND STANDARD PLANS.

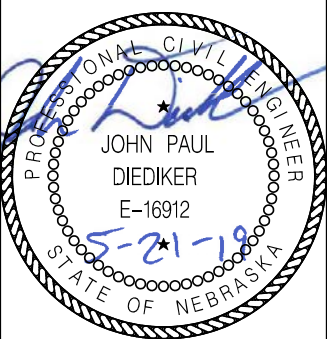

FIBER DESIGN

PROJECT NO.	SHEET NO.
017-0140	F.2
Date: 05/21/2019	Drawn: TMR
	Checked: STS
Horz. Scale 1 : 100	Approved: JPD

PROJECT: 21830-82ND & BENNET ROAD MOVE

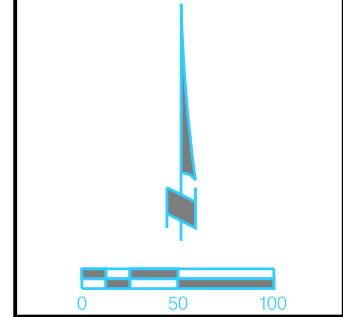

PRIOR TO CONSTRUCTION:

CALL 811 FOR LOCATION OF UNDERGROUND TELEPHONE, ELECTRIC, GAS MAINS, CABLE TELEVISION AND OTHER UTILITIES.

EXISTING UNDERGROUND AND OVERHEAD UTILITIES AND DRAINAGE STRUCTURES HAVE BEEN PLOTTED FROM AVAILABLE INFORMATION AND THEREFORE, THEIR LOCATIONS MUST BE CONSIDERED APPROXIMATE ONLY. IT IS THE RESPONSIBILITY OF THE INDIVIDUAL CONTRACTORS TO EXACTLY LOCATE AND PROTECT EACH EXISTING UTILITY BEFORE AND DURING ACTUAL CONSTRUCTION.

CONSTRUCTION SHALL MEET LANCASTER COUNTY STANDARD CONSTRUCTION SPECIFICATIONS AND STANDARD PLANS.

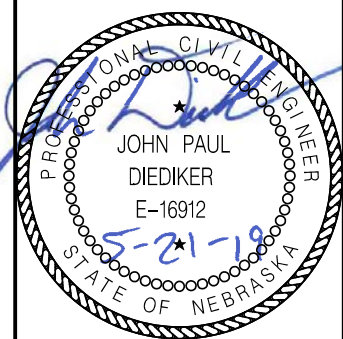

FIBER DESIGN



MATCH LINE SHEET F.1

MATCH LINE SHEET F.3

USER: field
 DATE: 05/21/2019
 DGN: F:\2017\0001-0500\017-0140-21830-82nd & Bennet Road Move\10-Design\Microstation\Telecom_LNK_017-0140_21830_82nd & Bennet Road Move\Sheets\F.2.dgn

USER: field
 DATE: 05/21/2019
 DGN: F:\2017\0001-0500\017-0140-21830-82nd & Bennet Road Move\Telecom_LNK\017-0140_21830_82nd & Bennet Road Move\Sheets\F.3.dgn

MATCH LINE SHEET F.2



MATCH LINE SHEET F.4

PROJECT NO.	SHEET NO.
017-0140	F.3
Date: 05/21/2019	Drawn: TMR
Horz. Scale 1 : 100	Checked: STS
	Approved: JPD

PROJECT: 21830-82ND & BENNET ROAD MOVE

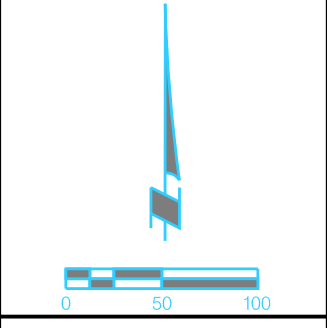

PRIOR TO CONSTRUCTION:

CALL 811 FOR LOCATION OF UNDERGROUND TELEPHONE, ELECTRIC, GAS MAINS, CABLE TELEVISION AND OTHER UTILITIES.

EXISTING UNDERGROUND AND OVERHEAD UTILITIES AND DRAINAGE STRUCTURES HAVE BEEN PLOTTED FROM AVAILABLE INFORMATION AND THEREFORE, THEIR LOCATIONS MUST BE CONSIDERED APPROXIMATE ONLY. IT IS THE RESPONSIBILITY OF THE INDIVIDUAL CONTRACTORS TO EXACTLY LOCATE AND PROTECT EACH EXISTING UTILITY BEFORE AND DURING ACTUAL CONSTRUCTION.

CONSTRUCTION SHALL MEET LANCASTER COUNTY STANDARD CONSTRUCTION SPECIFICATIONS AND STANDARD PLANS.

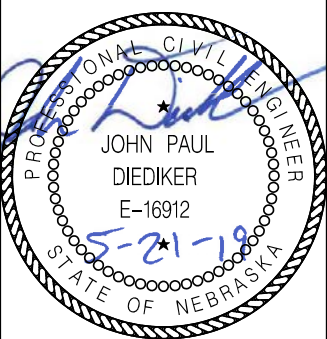

FIBER DESIGN

PROJECT NO.	SHEET NO.
017-0140	F.4
Date: 05/21/2019	Drawn: TMR
	Checked: STS
Horz. Scale 1 : 100	Approved: JPD

PROJECT: 21830-82ND & BENNET ROAD MOVE

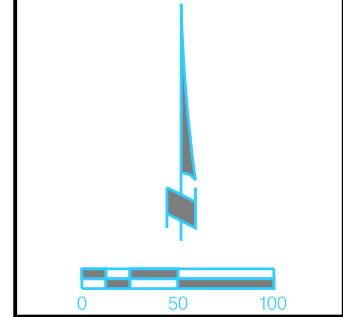

PRIOR TO CONSTRUCTION:

CALL 811 FOR LOCATION OF UNDERGROUND TELEPHONE, ELECTRIC, GAS MAINS, CABLE TELEVISION AND OTHER UTILITIES.

EXISTING UNDERGROUND AND OVERHEAD UTILITIES AND DRAINAGE STRUCTURES HAVE BEEN PLOTTED FROM AVAILABLE INFORMATION AND THEREFORE, THEIR LOCATIONS MUST BE CONSIDERED APPROXIMATE ONLY. IT IS THE RESPONSIBILITY OF THE INDIVIDUAL CONTRACTORS TO EXACTLY LOCATE AND PROTECT EACH EXISTING UTILITY BEFORE AND DURING ACTUAL CONSTRUCTION.

CONSTRUCTION SHALL MEET LANCASTER COUNTY STANDARD CONSTRUCTION SPECIFICATIONS AND STANDARD PLANS.

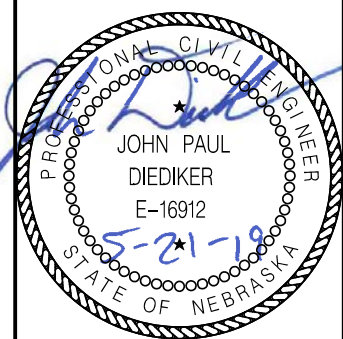

FIBER DESIGN



MATCH LINE SHEET F.3

MATCH LINE SHEET F.5

USER: field
 DATE: 05/21/2019
 DGN: F:\2017\0001-0500\017-0140-21830-82nd & Bennet Road Move\Telecom\LINK_017-0140_21830_82nd & Bennet Road Move\Sheets\F.4.dgn

MATCH LINE SHEET F.7

PROJECT NO.	SHEET NO.
017-0140	F.5
Date: 05/21/2019	Drawn: TMR
	Checked: STS
Horz. Scale 1 : 100	Approved: JPD

PROJECT: 21830-82ND & BENNET ROAD MOVE

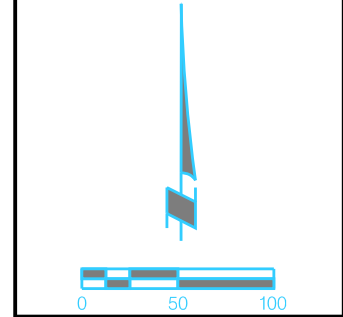

PRIOR TO CONSTRUCTION:

CALL 811 FOR LOCATION OF UNDERGROUND TELEPHONE, ELECTRIC, GAS MAINS, CABLE TELEVISION AND OTHER UTILITIES.

EXISTING UNDERGROUND AND OVERHEAD UTILITIES AND DRAINAGE STRUCTURES HAVE BEEN PLOTTED FROM AVAILABLE INFORMATION AND THEREFORE, THEIR LOCATIONS MUST BE CONSIDERED APPROXIMATE ONLY. IT IS THE RESPONSIBILITY OF THE INDIVIDUAL CONTRACTORS TO EXACTLY LOCATE AND PROTECT EACH EXISTING UTILITY BEFORE AND DURING ACTUAL CONSTRUCTION.

CONSTRUCTION SHALL MEET LANCASTER COUNTY STANDARD CONSTRUCTION SPECIFICATIONS AND STANDARD PLANS.

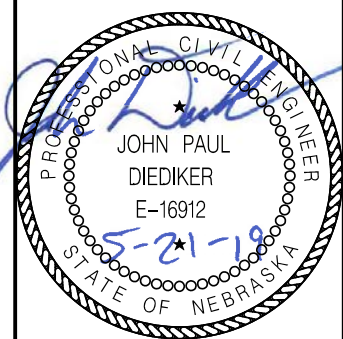

FIBER DESIGN

MATCH LINE SHEET F.4

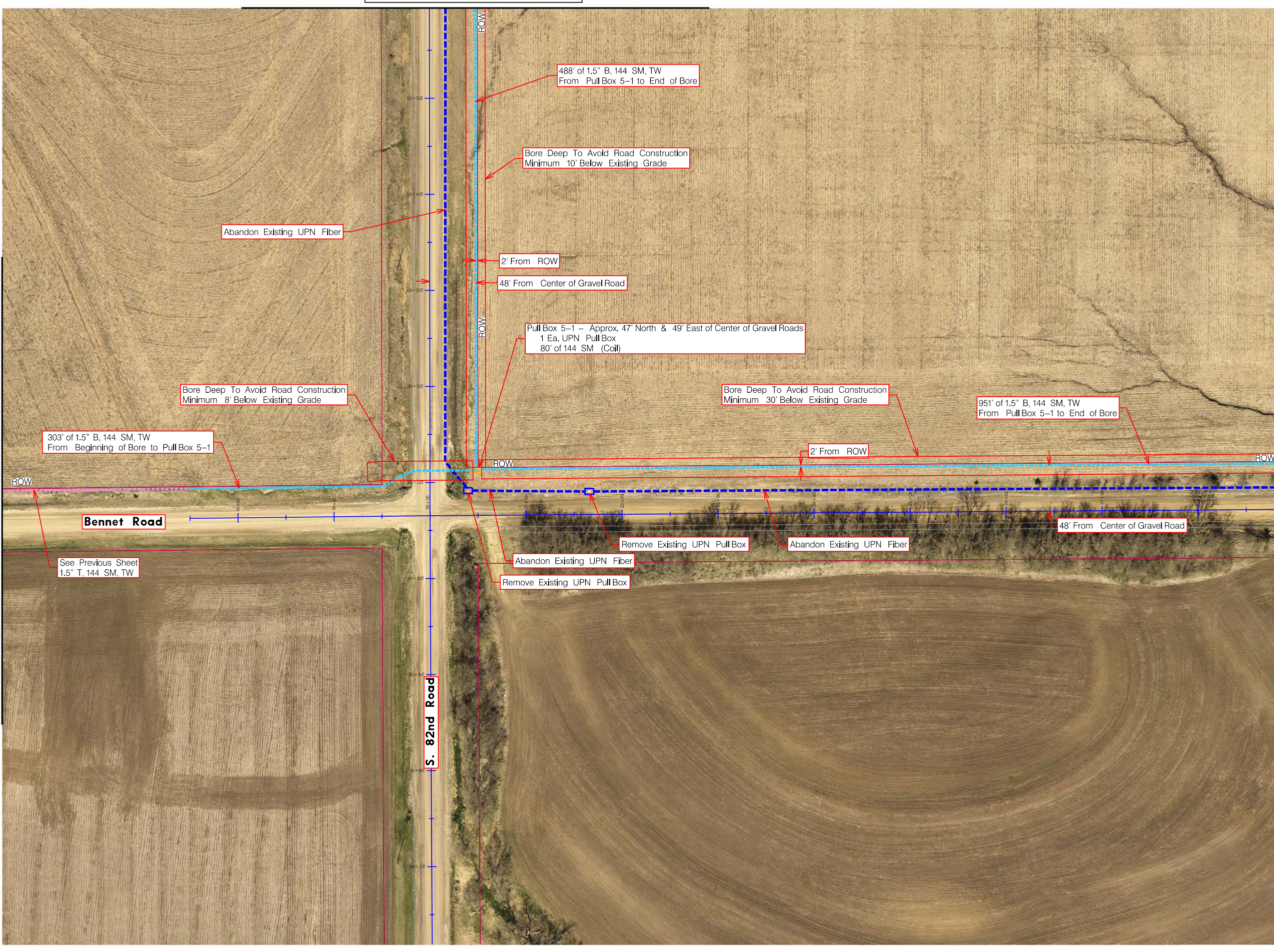

MATCH LINE SHEET F.6

USER: field
 DATE: 05/21/2019
 DGN: F:\2017\0001-0500\017-0140-21830-82nd & Bennet Road Move\Telecom\LNK_017-0140_21830_82nd & Bennet Road Move\Sheets\F.5.dgn

PROJECT NO.	SHEET NO.
017-0140	F.6
Date: 05/21/2019	Drawn: TMR
Horz. Scale 1 : 100	Checked: STS
	Approved: JPD

PROJECT: 21830-82ND & BENNET ROAD MOVE

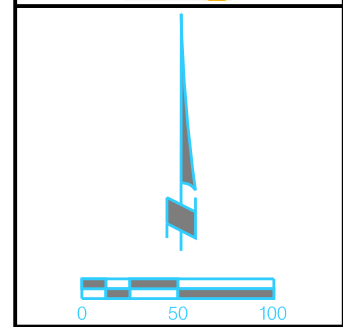

PRIOR TO CONSTRUCTION:

CALL 811 FOR LOCATION OF UNDERGROUND TELEPHONE, ELECTRIC, GAS MAINS, CABLE TELEVISION AND OTHER UTILITIES.

EXISTING UNDERGROUND AND OVERHEAD UTILITIES AND DRAINAGE STRUCTURES HAVE BEEN PLOTTED FROM AVAILABLE INFORMATION AND THEREFORE, THEIR LOCATIONS MUST BE CONSIDERED APPROXIMATE ONLY. IT IS THE RESPONSIBILITY OF THE INDIVIDUAL CONTRACTORS TO EXACTLY LOCATE AND PROTECT EACH EXISTING UTILITY BEFORE AND DURING ACTUAL CONSTRUCTION.

CONSTRUCTION SHALL MEET LANCASTER COUNTY STANDARD CONSTRUCTION SPECIFICATIONS AND STANDARD PLANS.

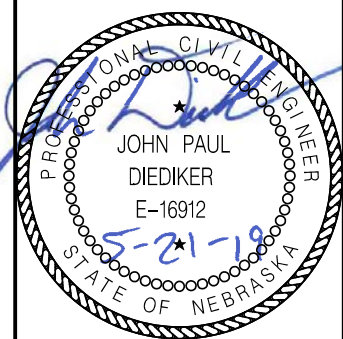

FIBER DESIGN

MATCH LINE SHEET F.5

USER: field DATE: 05/21/2019 DGN: F:\2017\0001-0500\017-0140-21830-82nd & Bennet Road Move\10-Design\Microstation\Telecom_LNK_017-0140_21830_82nd & Bennet Road Move\Sheets\F.6.dgn



PROJECT NO.	SHEET NO.
017-0140	F,7
Date: 05/21/2019	Drawn: TMR
Horz. Scale 1 : 100	Checked: STS
	Approved: JPD

PROJECT: 21830-82ND & BENNET ROAD MOVE

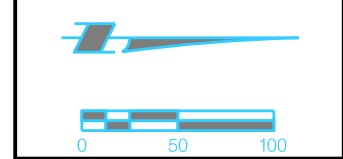

PRIOR TO CONSTRUCTION:

CALL 811 FOR LOCATION OF UNDERGROUND TELEPHONE, ELECTRIC, GAS MAINS, CABLE TELEVISION AND OTHER UTILITIES.

EXISTING UNDERGROUND AND OVERHEAD UTILITIES AND DRAINAGE STRUCTURES HAVE BEEN PLOTTED FROM AVAILABLE INFORMATION AND THEREFORE, THEIR LOCATIONS MUST BE CONSIDERED APPROXIMATE ONLY. IT IS THE RESPONSIBILITY OF THE INDIVIDUAL CONTRACTORS TO EXACTLY LOCATE AND PROTECT EACH EXISTING UTILITY BEFORE AND DURING ACTUAL CONSTRUCTION.

CONSTRUCTION SHALL MEET LANCASTER COUNTY STANDARD CONSTRUCTION SPECIFICATIONS AND STANDARD PLANS.

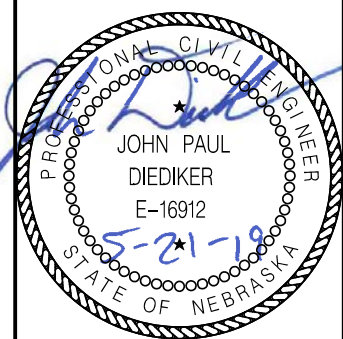

FIBER DESIGN

MATCH LINE SHEET F.5

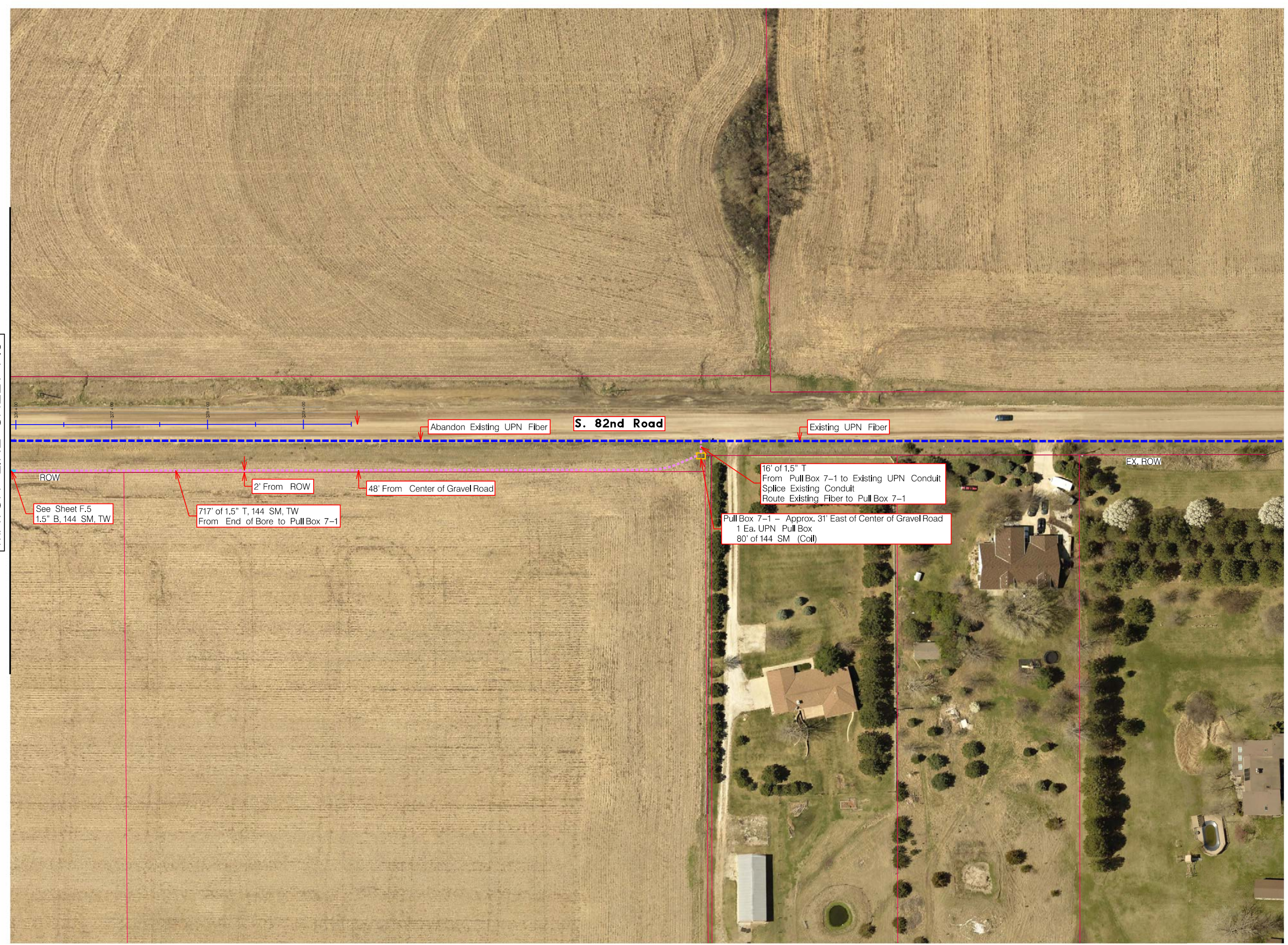

USER: field
 DATE: 05/21/2019
 DGN: F:\2017\0001-0500\017-0140-21830-82nd & Bennet Road Move\40-Design\Microstation\Telecom_LNK_017-0140_21830_82nd & Bennet Road Move_Sheets\F,7.dgn