

AMENDMENT TO CONTRACT
Annual Supply
Workstations and Accessories
Bid No. 17-140
City of Lincoln, Lancaster County and
City of Lincoln-Lancaster County Public Building Commission
Renewal with Price Increase
Office Interiors & Design, Inc.

This Amendment is hereby entered into by and between Office Interiors & Design, Inc., 121 Cherry Hill Blvd., Lincoln, NE 68510 (hereinafter "Contractor") and the City of Lincoln, Lancaster County and the City of Lincoln-Lancaster County Public Building Commission (hereinafter "Owners"), for the purpose of amending the Contract dated August 10, 2017 executed under City Directorial Order No. 17628, and County Contract C-17-0646, dated August 15, 2017, and executed by the City of Lincoln-Lancaster County Public Building Commission, on September 12, 2017, for Annual Supply - Workstations and Accessories, Bid No. 17-140, which is made a part of this amendment by this reference.

WHEREAS, the original term of the Contract is September 12, 2017 through September 11, 2018, with the option to renew for three (3) additional one (1) year terms upon written mutual consent by all parties; and

WHEREAS, the parties hereby renew the Contract for an additional one (1) year term beginning September 12, 2018 through September 11, 2019; and

WHEREAS, the parties hereby amend the Contract to reflect a price increase for the items listed per Attachment A; and

WHEREAS, the expenditures for the City of Lincoln for the term of this renewal shall not exceed \$30,000.00 without approval by the City of Lincoln; and

WHEREAS, the expenditures for Lancaster County for the term of this renewal shall not exceed \$10,000.00 without approval by the Lancaster County Board; and

WHEREAS, the expenditures for the City of Lincoln-Lancaster County Public Building Commission for the term of this renewal shall not exceed \$500.00 without approval by the Public Building Commission; and

NOW, THEREFORE, IN CONSIDERATION of the mutual covenants contained in the Contract under City Directorial Order No. 17628 and County Contract C-17-0646, all amendments thereto, and as stated herein, the parties agree as follows:

- 1) The parties hereby renew the Contract for an additional one (1) year term beginning September 12, 2018 through September 11, 2019.
- 2) The parties hereby amend the Contract to reflect a price increase for the items listed per Attachment A.
- 3) The expenditures for the City of Lincoln for the term of this renewal shall not exceed \$30,000.00 without approval by the City of Lincoln.
- 4) The expenditures for Lancaster County for the term of this renewal shall not exceed \$10,000.00 without approval by the Lancaster County Board.
- 5) The expenditures for the City of Lincoln-Lancaster County Public Building Commission for the term of this renewal shall not exceed \$500.00 without approval by the Public Building Commission.
- 6) All other terms of the Contract, not in conflict with this Amendment, shall remain in force and effect.

The Parties do hereby agree to all the terms and conditions of this Amendment. This Amendment shall be binding upon the parties, their heirs, administrators, executors, legal and personal representatives, successors, and assigns.

IN WITNESS WHEREOF, the Parties do hereby execute this Amendment upon completion of signatures on:

Vendor Signature Page

City of Lincoln Signature Page

Lancaster County Signature Page

City of Lincoln-Lancaster County Public Building Commission Signature Page

Vendor Signature Page

**AMENDMENT TO CONTRACT
Annual Supply
Workstations and Accessories
Bid No. 17-140
City of Lincoln, Lancaster County and
City of Lincoln-Lancaster County Public Building Commission
Renewal with Price Increase
Office Interiors & Design, Inc.**

Please sign, date and return within 5 days of receipt.

Mail to: City/County Purchasing
Attn: Brianne Crooks
440 So. 8th St., Ste. 200
Lincoln, NE 68508
Or email to: bcrooks@lincoln.ne.gov

Company Name:	OFFICE Interiors & Design
By: (Please Sign)	Nancy Kraft
By: (Please Print)	Nancy Kraft
Title:	Director of Workplace Solutions
Company Address:	121 Cherry Hill Blvd. Lincoln, NE
Company Phone & Fax:	402 484 7500
E-Mail Address:	nancy.kraft@oidinc.com
Date:	8/29/18
Contact Person for Orders or Service	Nancy Kraft
Contact Phone Number:	402 484 7500 402 730 7262 cell

City of Lincoln Signature Page

**AMENDMENT TO CONTRACT
Annual Supply
Workstations and Accessories
Bid No. 17-140
City of Lincoln, Lancaster County and
City of Lincoln-Lancaster County Public Building Commission
Renewal with Price Increase
Office Interiors & Design, Inc.**

EXECUTION BY THE CITY OF LINCOLN, NEBRASKA

ATTEST:

City Clerk

CITY OF LINCOLN, NEBRASKA

Chris Beutler, Mayor

Approved by Executive Order No. _____

dated _____

Lancaster County Signature Page

**AMENDMENT TO CONTRACT
Annual Supply
Workstations and Accessories
Bid No. 17-140
City of Lincoln, Lancaster County and
City of Lincoln-Lancaster County Public Building Commission
Renewal with Price Increase
Office Interiors & Design, Inc.**

EXECUTION BY LANCASTER COUNTY, NEBRASKA

Contract Approved as to Form:

The Board of County Commissioners of
Lancaster, Nebraska

Deputy Lancaster County Attorney

dated _____

**City of Lincoln-Lancaster County Public Building Commission
Signature Page**

**AMENDMENT TO CONTRACT
Annual Supply
Workstations and Accessories
Bid No. 17-140
City of Lincoln, Lancaster County and
City of Lincoln-Lancaster County Public Building Commission
Renewal with Price Increase
Office Interiors & Design, Inc.**

EXECUTION BY LINCOLN-LANCASTER COUNTY PUBLIC BUILDING COMMISSION

ATTEST:

Public Building Commission Attorney

Chairperson, Public Building Commission

dated _____

2018-2019 Booklet

Prepared for:



BID NUMBER: 17-140

Ergonomics Workstations & Accessories Bid

REVISED: July 2018



ELECTRIC / HEIGHT ADJUSTABLE / COMPLETE DESK

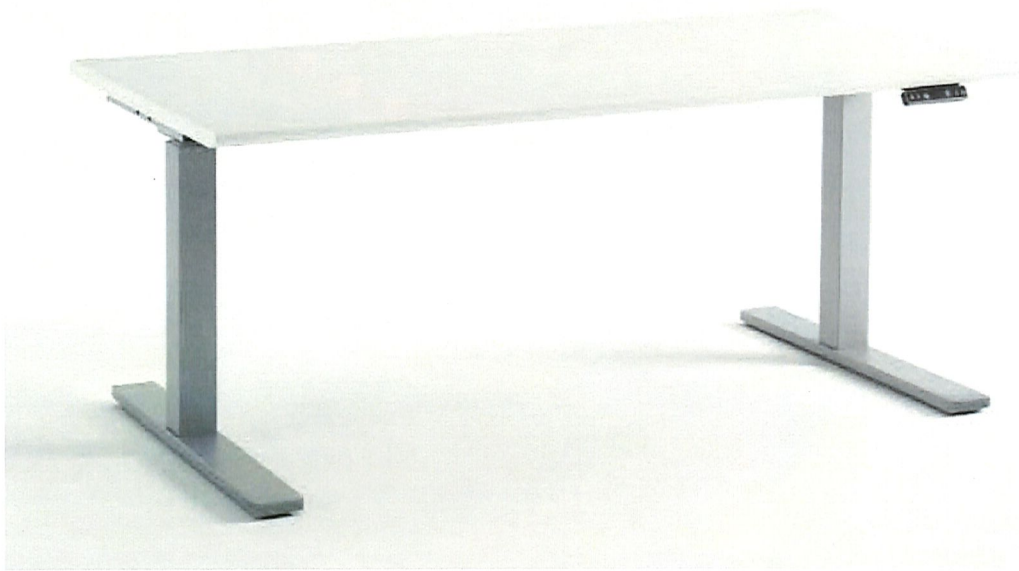

TEKNION / HiSPACE ELECTRIC DESK

**Complete Height Adjustable Desk w/ Top*

<http://www.teknion.com/ca/products/galleries/hispace-gallery>

- Foundation HPL Laminate Top
- Platinum (Silver) Metal Base
- Memory Display Switch
- 200lb Rise Capacity
- Range: 25.5" – 50.5"H

24"D x 48"W	\$658.00
30"D x 60"W	\$704.00
30"D x 72"W	\$730.00
(*Available 24-30"D x 48-72"W)	
Installation Estimate	\$150



ELECTRIC / HEIGHT ADJUSTABLE / BASE ONLY

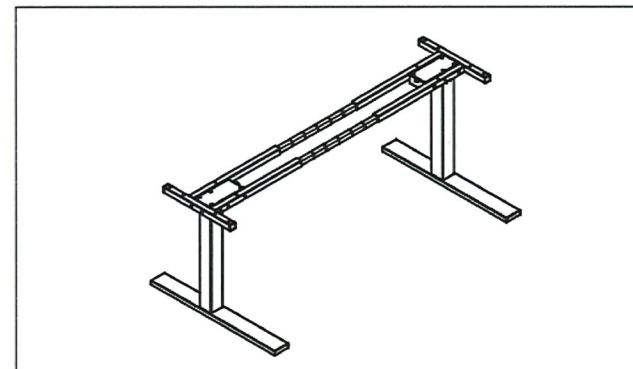

TEKNION / HiSPACE ELECTRIC BASE ONLY

**Base Only (For retrofitting existing rectangle tops)*

<http://www.teknion.com/ca/products/galleries/hispace-gallery>

- Platinum (Silver) Metal Base
- (*Available 24"-30"D x 48"-72"W)
- Memory Display Switch
- 200lb Rise Capacity
- Range: 25.5" – 50.5"H

24"-30"D x 48"-72W \$541.50

(*Telescoping base fits under a variety of sized tops)

Installation Estimate \$125



COUNTERBALANCE / HEIGHT ADJUSTABLE / COMPLETE DESK



TEKNION / LIVELLO COUNTERBALANCE

**Complete Height Adjustable Desk w/ Top*

<http://www.teknion.com/products/galleries/livello-tables-gallery>

Foundation HPL Laminate Top

Foundation Metal Base

(*Available 24-30"D x 42-84"W)

150lb Rise Capacity (minus weight of worksurface)

Counterbalance Mechanism

Standard Range: 29" – 49"H

Extended Range: 26" – 43"H

24"D x 48"W	\$877.75
30"D x 60"W	\$938.50
30"D x 72"W	\$978.75
Installation Estimate	\$150



COUNTERBALANCE / HEIGHT ADJUSTABLE / BASE ONLY



TEKNION / LIVELLO COUNTERBALANCE

**Base Only (For retrofitting existing rectangle desks)*

<http://www.teknion.com/products/galleries/livello-tables-gallery>

Foundation Metal Base

(*Available 24-30"D x 42-84"W)

150lb Rise Capacity (minus weight of worksurface)

Counterbalance Mechanism

Standard Range: 29" – 49"H

Extended Range: 26" – 43"H

24"D x 48"W	\$810.00
30"D x 60"W	\$873.50
30"D x 72"W	\$891.50
Installation Estimate	\$125



ELECTRIC / HEIGHT ADJUSTABLE / BASE ONLY (Extended Corner)



ESI Victory-LX - 2 Leg Base Only
2VT-LX-C48-24/30

**Base Only (For retrofitting existing extended corner desks)*

<https://www.esiergo.com/height-adjustable-tables/electric-table-bases/sp/victory-lx-2-leg/>

Silver Standard; White or Black optional
Basic Up/Down Switch
Range: 22" - 47"H
220lb Rise Capacity
Exceeds BIFMA x5.5 requirements

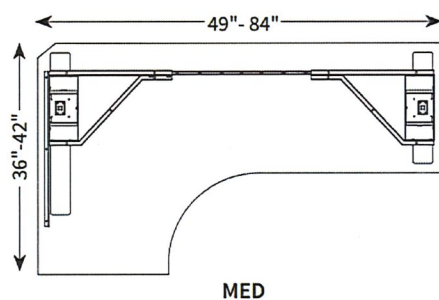

DIGITAL KEYPAD INCLUDED WITH BASE



- Digital programmable switch with 3 memory settings
- Keypad can slide under worksurface to store out of the way

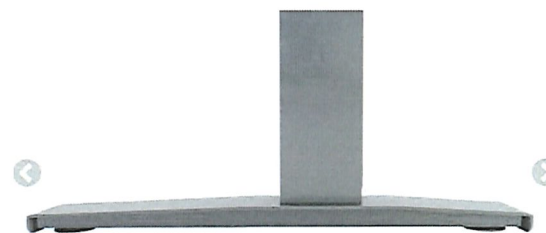

36-42"D x 48"-84W \$531.00

Freight: 1-4 Bases \$150 Flat
 5+ Bases Free

(*Telescoping base fits under a variety of sized tops)

Installation Estimate \$125



ELECTRIC / HEIGHT ADJUSTABLE / BASE ONLY (3-Leg)



BASE ONLY

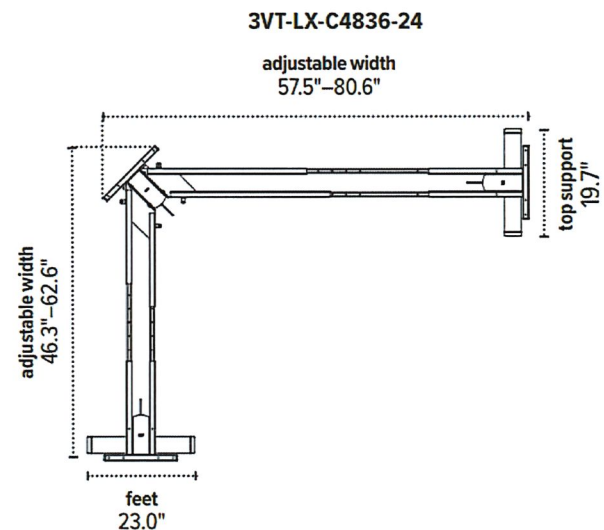

ESI Victory-LX - 3 Leg Base Only
3VT-LX-C4836-24

**Base Only (For retrofitting existing extended corner desks)*

<https://www.esiergo.com/height-adjustable-tables/electric-table-bases/sp/victory-lx-3-leg/>

Silver Standard; White or Black optional
Basic Up/Down Switch
Range: 22" – 47"H
320lb Rise Capacity
Exceeds BIFMA x5.5 requirements

48-84"D x 48"-84W	\$659.70
Freight:	1-4 Bases \$150 Flat
	5+ Bases Free
(*Telescoping base fits under a variety of sized tops)	
Installation Estimate	\$150



HEIGHT ADJUSTABLE / DESK MOUNTED



Humanscale's QuickStand Eco is the next generation in portable sit/stand solutions.

Sleeker, easier to use and comprised of more sustainable materials than ever before, it is a vast improvement over the current generation of sit/stand surfaces. QuickStand Eco features simple setup, portability and near effortless adjustability — transforming ordinary desktops into healthy, active workspaces.

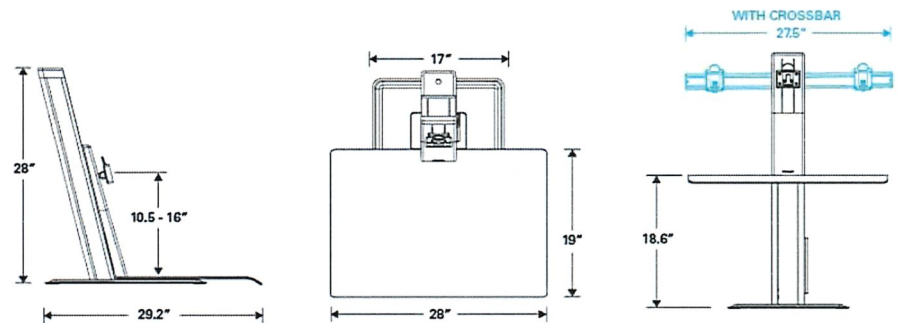

HUMANSCALE / QUICKSTAND ECO – Single or Double

<https://www.humanscale.com/products/product.cfm?group=quickstandeco>

White or Black

Dimensions: 28.1" H (in resting position) x 28" W x 29.2" D
 Work Surface: 28" W (710mm) x 19" D (480mm)
 Minimum Desk Required - 29" Product Weight:
 Laptop - 38.5 lbs. (17.5 kg)
 Single Monitor - 42.3 lbs. (19.2 kg)
 Dual Monitor - 45 lbs. (20.5 kg)
 Product Weight with Box:
 Laptop - 51.2 lbs. (23.2 kg)
 Single Monitor - 55.0 lbs. (24.9 kg)
 Dual Monitor - 57.7 lbs. (26.2 kg)
 Vertical Monitor Adjustment - 5"
 Total Height Range - 18.6"

Single Monitor	\$378.25
Double Monitor	\$432.37
Installation	\$55



HEIGHT ADJUSTABLE / DESK MOUNTED



QuickStand Lite features an innovative counterbalance mechanism that enables users of varying heights to transition from sitting to standing positions with ease, offering 20" of total height range and an added 5.5" of vertical monitor adjustment. Its effortless functionality encourages users to be active throughout the day.



HUMANSCALE / QUICKSTAND LITE – Single or Double

**Attaches to existing desktop – Clamp or Bolt Mounted*

<https://www.humanscale.com/products/product.cfm?group=quickstandlite>

Silver or Black

Weight capacity is 22lbs

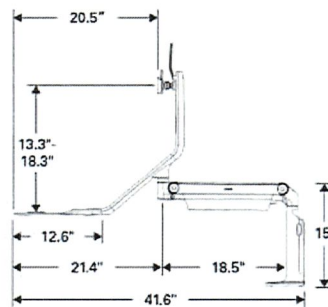

Light Single Monitor	\$459.43
Heavy Single Monitor	\$486.48
Light Double Monitor	\$513.54
Wide Double Monitor	\$524.37
Installation	\$55



HEIGHT ADJUSTABLE / DESK MOUNTED



HUMANSCALE / QUICKSTAND

**Attaches to existing desktop – Clamp or Bolt Mounted*

(Also available as a freestanding base)

<https://www.humanscale.com/products/product.cfm?group=>

Black or White

Monitors up to 30lbs

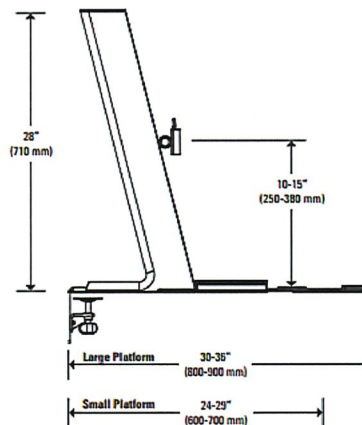

Single Heavy, Small Platform \$537.90
 Single Heavy, Large Platform \$592.01

Standard Double, Small Platform \$564.95
 Standard Double, Large Platform \$592.01

Wide Double, Small Platform \$575.77
 Wide Double, Large Platform \$602.84

Installation \$55



MONITOR ARMS



INNOVATIVE / FREEDOM DESK

Available in three sizes: 30", 36" and 42".

<http://innovativeworkspaces.com/product/ergotech-freedom-desk/>

Spring assisted to raise and lower in seconds
Upper desk surface has a 10mm bolt-thru hole for mounting an optional monitor arm.
Ships fully assembled, no installation required.
5 Year Warranty
Black or White



30"W	\$284.00
36"W	\$358.00
42"W	\$330.00
Freight	\$28.00 EACH
Installation	\$55



KEYBOARD TRAYS

6G90090HG22

\$170.21

Installation

\$55

(Balance-M/TRACKLESS)-(LO \$218.46

Installation

\$55

SOLUTIONULTRA

\$216.79

Installation

\$55

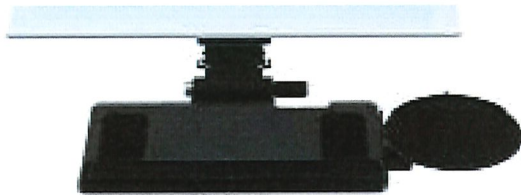

HUMANSCALE / KEYBOARD TRAY

6G90090HF22

https://www.humanscale.com/products/category_detail.cfm?category=keyboard_systems

Black
Standard Mechanism / Platform
9" Clip Mouse High
19" Foam Palm Support w/ Synthetic Leather Cover
22" Track Length

*Installation labor to be quoted as required; including vendor to perform a site visit to measure and determine proper needs of the workspace.



SYMMETRY / TRACKLESS KEYBOARD TRAY (for Height Adjustable Worksurfaces)

Balance-M/TRACKLESS)-(LO

<http://www.symmetryoffice.com/tableBuilder/index.cfm?pid=245>

Black
Standard Mechanism for Height Adjustable Surfaces
Includes Mouse Pad and Mouse Guard



ESI / KEYBOARD TRAY

SOLUTIONULTRA

<https://www.esiergo.com/keyboard-solutions/combo-solutions/sp/solution-ultra/>

PL217 SWITCH-N-CLICK PLATFORM
18.75" keyboard platform
9.25" Switch-n-Click mousing platform

Designed to complement radius corner work surfaces and position the keyboard closer to the work area.

AA360 ARTICULATING ARM

21" glide track, Lift and Lock
7" height adjustment
High: 2.5" above track
Low: 4.5" below track



MONITOR ARMS

DOUBLE MONITOR ARM



SINGLE MONITOR ARM



ESI / EVOLVE-F

EVOLVE1-F // EVOLVE2-F

<https://www.esiergo.com/monitor-arms/single/sp/evolve1-f/>

<https://www.esiergo.com/monitor-arms/dual/sp/evolve2-f/>

Single and Dual Monitor Arm.
Manual Height Adjustment.

Monitor Extension: 16.25"
Monitor Retraction: 3"
Monitor Tilt: +90°/-25°
Monitor Rotation: +90°/-90°
Weight Capacity (per arm):
Maximum: 20 lbs
180° Lock-Out Feature
Quick Release
16" Pole
Desk clamp & grommet mount included
Max Monitor Width: 27" (bezel measured left to right)

Single Monitor Arm	\$149.03
Double Monitor Arm	\$239.90
Freight	\$25.00 ea
Installation	\$55



MONITOR ARMS

M2CS2S	\$140.00
Installation	\$55

*Installation labor to be quoted as required; including vendor to perform a site visit to measure and determine proper needs of the workspace.



HUMANSCALE / M2 SINGLE

M2CS2S

<https://www.humanscale.com/products/product.cfm?group=M2>

Articulating Arm w/ Spring Tension Technology
 Silver, Polished Aluminum or Black
 Desk Clamp Mount OR Bolt Through Mount
 Fixed Straight Link / Dynamic Link Arm Style
 Standard VESA Plate

SINGLE	\$164.12
DOUBLE	\$275.29
Installation	\$55

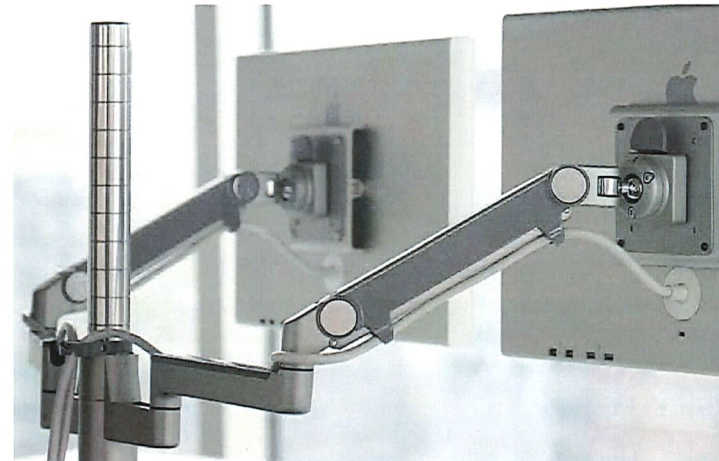

HUMANSCALE / MFLEX

*Single or Double

MF21S2C12 // MF22S22C12

<https://www.humanscale.com/products/product.cfm?group=M2>

Articulating Arm w/ Spring Tension Technology
 Silver, Polished Aluminum or Black
 Bolt or Clamp Mount
 Fixed Straight Link / Dynamic Link Arm Style
 12"H Post
 Standard VESA Plate



VALUES

EXCELLENCE

Office Interiors & Design is committed to excellence in all aspects of interior design and furniture products and services; in communication, space planning and design, CAD drawing, furniture specification, finish selection, order placement, receiving, warehousing, installation and client wrap-up; in the hiring of the absolute best people and continuing professional development of everyone; in all administrative policies and procedures; and participation in the communities that fuel the continual reinvigoration of the interior design community.

LISTENING

Remaining ever mindful that each client is a unique individual or group, with unique and specific requirements, the employees of OID are committed to sharing the client vision; through active listening, providing thoughtful, individualized solutions, and remaining flexible of mind, the shared vision is attained.

STEWARDSHIP

As a mid-western, family owned company we recognize that our company's strength comes from our people; and that our people come from our community. OID is committed to fostering a love of design in young people and we pledge to continue to support local design students and curricula.

KNOWLEDGE

OID has extensive experience and product expertise across many markets; including corporate, government, public spaces, technology and higher education. From top to bottom, we understand the specific markets we serve.

We utilize the latest technology to accommodate client needs quickly. Planning, specifications, ordering and tracking orders are managed in a way that ensures speed and accuracy.

PEOPLE

We pride ourselves on the knowledge, expertise and professionalism of our entire company. Many of our employees have been with the company for over 15 years, and we are continually honored with an incredible employee retention rate as well as a commitment to ongoing training.

Our service team is comprised of extremely dependable and professional individuals that continue to reinforce the positive experience of working with our company.

MISSION

Office Interiors & Design, Inc. is a full-service commercial furniture dealership dedicated to delivering an enjoyable, professional client experience; ever-striving to realize the client vision while strictly adhering to budget and schedule.

OID was founded by Dian Pickerel in 1995 and remains a family-owned, women-owned business.

OID is a client-first company that positions itself for long-term success by committing to client delight.

OID is pledged to excellence of client experience and creating the amazing spaces of our client's vision and that the design, administrative and installation teams are trained experts; ready to assist clients in all phases of the process, communicate effectively, and create solutions.

Office Interiors & Design intends that its clients achieve all of their project goals and are delighted by the process and results.

VISION

Office Interiors & Design, Inc. is a preeminent regional commercial furniture dealership, where the furniture experience transforms every client into an earnest, vocal advocate of our firm.



SERVICES

OID is a single source resource for all commercial furniture needs across a variety of markets. We support clients from space planning through furniture assembly and move in, as well as post occupancy needs. It's our job to take the hassle out of creating smart furniture solutions.



DESIGN

We offer full design services including workplace strategy, typical development, 3D renderings, space planning, technical specification, fabric and finish selections, installation drawings and field verification.



CUSTOMIZATION

We help our clients achieve a vision that also fits with their organizations branding and goals. Our manufacturer partners allow us to customize everything from colors, finishes, fabrics, furniture design, and more. Each product is truly designed to order the way you want it.



PRODUCT SOLUTIONS

As workplace design and project management specialists, we help create and refine your vision for the office. We provide idea starters, full floor plan product selections, and offerings that fit within your budget.

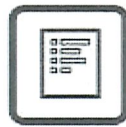

PROJECT MANAGEMENT

Our experienced Project Leads provide you one point of contact to tailor your project to specific budget and schedule needs. Dedicated Project Leads guide you through every step including planning, installation and revisions.



INSTALLATION

We outline your schedule and communication plan, and our team will oversee the production and installation processes to ensure they run smoothly. We are committed to finishing well through our team, and our partner installers, of courteous, prompt and professional installers.



THIS ENDORSEMENT CHANGES THE POLICY. PLEASE READ IT CAREFULLY.

ADDITIONAL INSURED – OWNERS, LESSEES OR CONTRACTORS – SCHEDULED PERSON OR ORGANIZATION

This endorsement modifies insurance provided under the following

COMMERCIAL GENERAL LIABILITY COVERAGE PART

SCHEDULE

Name Of Additional Insured Person(s) Or Organization(s)	Location(s) Of Covered Operations
City of Lincoln and Lancaster County and City of Lincoln/Lancaster County Public Building Commission	Multiple locations for The City of Lincoln/Lancaster County
Information required to complete this Schedule, if not shown above, will be shown in the Declarations.	

A. Section II – Who is An Insured is amended to include as an additional insured the person(s) or organization(s) shown in the Schedule, but only with respect to liability for "bodily injury", "property damage" or "personal and advertising injury" caused, in whole or in part, by:

1. Your acts or omissions; or
2. The acts or omissions of those acting on your behalf;

in the performance of your ongoing operations for the additional insured(s) at the location(s) designated above.

However:

1. The insurance afforded to such additional insured only applies to the extent permitted by law; and
2. If coverage provided to the additional insured is required by a contract or agreement, the insurance afforded to such additional insured will not be broader than that which you are required by the contract or agreement to provide for such additional insured.

B. With respect to the insurance afforded to these additional insureds, the following additional exclusions apply:

This insurance does not apply to "bodily injury" or "property damage" occurring after:

1. All work, including materials, parts or equipment furnished in connection with such work, on the project (other than service, maintenance or repairs) to be performed by or on behalf of the additional insured(s) at the location of the covered operations has been completed; or
2. That portion of "your work" out of which the injury or damage arises has been put to its intended use by any person or organization other than another contractor or subcontractor engaged in performing operations for a principal as a part of the same project.

C. With respect to the insurance afforded to these additional insureds, the following is added to **Section III – Limits Of Insurance:**

If coverage provided to the additional insured is required by a contract or agreement, the most we will pay on behalf of the additional insured is the amount of insurance:

1. Required by the contract or agreement; or

2. Available under the applicable Limits of Insurance shown in the Declarations;
whichever is less.

This endorsement shall not increase the applicable Limits of Insurance shown in the Declarations.

SFM Safe Insurance Company
 Workers' Compensation and Employers' Liability Policy

Policy Information Page Endorsement

Named Insured and Mailing Address
 Office Interiors and Design Inc
 121 Cherry Hill Blvd
 Lincoln, NE 68510-2639

Agency and Mailing Address
 INSPRO Inc
 PO Box 6847
 Lincoln, NE 68506-0847

Policy No: 094137.201

Policy Period: 12/11/2017 - 12/11/2018

Endorsements Changed:

- Insured's Name (WC220602)
- Policy Number (WC220603)
- Effective Date (WC220604)
- Expiration Date (WC220605)
- Insured's Mailing Address (WC220606)
- Experience Modification (WC220607)
- Producer's Name (WC220608)
- Change in Workplace of Insured (WC220609)
- Insured's Legal Status (WC220610)
- Item 3.A. States (WC220611)
- Item 3.B. Limits (WC220612)
- Item 3.C. States (WC220613)
- Item 3.D. Endorsement Numbers (WC220614)
- Item 4. Class, Rate, Other (WC220615)
- Interim Adjustment of Premium (WC220616)
- Carrier Servicing Office (WC220617)
- Interstate/Intrastate Risk ID Number (WC220618)
- Carrier Number (WC220619)

Description of Change:

In consideration of an ADDITIONAL PREMIUM of \$132., as per attached "Revised" WC-4 Installment Endorsement, it is agreed that Endorsement WC 00 03 13 Waiver of our Right to Recover from Others Endorsement is attached to and forms a part of the policy.

Classification Description	Class Code	Premium Basis Total Estimated Annual Remuneration	Rate per \$100 of Remuneration	Estimated Annual Premium
----------------------------	------------	---	--------------------------------	--------------------------

Payroll From: 12/11/2017 - 06/23/2018

Clerical Office Employees Noc	8810	176,673	0.23	406
Salespersons Or Collect-Outsid	8742	58,756	0.68	400
Furniture Stores	8044	0	4.70	0
Waiver of Subrogation - Job	0930		1.05	53
Coverage B	9807		1.008	6
Additional to Balance Cov B	9848		0.00	34
Experience Mod	9898		1.32	288

Payroll From: 06/23/2018 - 12/11/2018

Clerical Office Employees Noc	8810	155,731	0.23	358
Salespersons Or Collect-Outsid	8742	51,791	0.68	352
Furniture Stores	8044	0	4.70	0
Waiver of Subrogation - Job	0930		1.05	47
Coverage B	9807		1.008	6
Additional to Balance Cov B	9848		0.00	29
Experience Mod	9898		1.32	253
Expense Constant	0900			240
Terrorism Risk Insurance	9740			44
Catastrophe Premium	9741			44

Classification Description	Class Code	Premium Basis Total Estimated Annual Remuneration	Rate per \$100 of Remuneration	Estimated Annual Premium
----------------------------	------------	---	--------------------------------------	--------------------------

Total Estimated Annual Premium	2,560
Previous Total Estimated Annual Premium	2,428
This reflects a additional premium of:	132

Change Effective Date: 12/11/2017

NCCI# 76093

SFM Safe Insurance Company
 Workers' Compensation and Employers' Liability Policy

Waiver Of Our Right To Recover From Others Endorsement

This endorsement changes the policy to which it is attached effective on the inception date of the policy unless a different date is indicated below.

This endorsement, effective on **12/11/2017** at 12:01 A.M. standard time, forms a part of Policy **094137.201** issued to **Office Interiors and Design Inc.**

We have the right to recover our payments from anyone liable for an injury covered by this policy. We will not enforce our right against the person or organization named in the Schedule. (This agreement applies only to the extent that you perform work under a written contract that requires you to obtain this agreement from us.)

This agreement shall not operate directly or indirectly to benefit anyone not named in the Schedule.

SCHEDULE

This waiver of subrogation endorsement applies to the state of Nebraska

City of Lincoln, Lancaster County &
 City of Lincoln -Lancaster County Public Building Commission
 555 S 10th St Lincoln NE 68508

Waiver of subrogation for address listed above has an estimated charge of 5% of the applicable manual premium, with a minimum premium of \$100. At audit the actual payrolls for this project will be obtained and the 5% charge will be adjusted accordingly.

Please keep separate payrolls records for this project available at the time of audit

Payroll Period: 12/11/2017 to 06/23/2018

Class/Description	Payroll	Rate	Premium
8044 Furniture Stores	0	4.70	0
8742 Salespersons Or Collect-Outsid	0	0.68	0
8810 Clerical Office Employees Noc	0	0.23	0

Payroll Period: 06/23/2018 to 12/11/2018

Class/Description	Payroll	Rate	Premium
8044 Furniture Stores	0	4.70	0
8742 Salespersons Or Collect-Outsid	0	0.68	0
8810 Clerical Office Employees Noc	0	0.23	0
Totals	0		0