

CONTRACT DOCUMENTS

LANCASTER COUNTY

NEBRASKA

For

Bid No. 18-141

Project No: 18-22

CRACK SEALING BITUMINOUS SURFACING

Scodeller Construction
51722 Grand River Ave
Wixom, MI 48393

LANCASTER COUNTY, NEBRASKA
CONTRACT AGREEMENT

THIS CONTRACT, made and entered into this _____ day of _____, _____, by and between Scodeller Construction, hereinafter called the Contractor, and the County of Lancaster, Nebraska, a political subdivision of the State of Nebraska, hereinafter called the County.

WHEREAS, the County has caused to be prepared in accordance with law, Specifications, Plans, and other Contract Documents for the Work herein described and has caused to be published an advertisement for and in connection with said Work, to-wit: Bid No. 18-141, Project No. 18-22, Crack Sealing Bituminous Surfacing; and

WHEREAS, the Contractor, in response to such advertisement, has submitted to the County, in the manner and at the time specified, a sealed Proposal in accordance with the terms of said advertisement; and

WHEREAS, the County, in the manner prescribed by law has publicly opened, read aloud, examined, and canvassed the Proposals submitted in response to such advertisement, and as a result of such canvass has determined and declared the Contractor to be the lowest responsible bidder for the said Work for the sum or sums named in the Contractor's Proposal, a copy thereof being attached to and made a part of this Contract.

NOW, THEREFORE, in consideration of the sums to be paid to the Contractor and the mutual covenants herein contained, the Contractor and the County hereby agree as follows:

1. The Contractor agrees to (a) furnish all tools, equipment, supplies, superintendence, transportation, and other construction accessories, services, and facilities; (b) furnish all materials, supplies, and equipment specified to be incorporated into and form a permanent part of the complete work; (c) provide and perform all necessary labor in a substantial and workmanlike manner and in accordance with the provisions of the Contract Documents; and (d) execute construct, and compete all work included in and covered by the County's award of this Contract to the Contractor, such award being based on the acceptance by the County of the Contractor's Proposal.
2. The County agrees to pay the Contractor for the performance of the work embraced in this Contract and the Contractor agrees to accept as full compensation therefor, the following sums for all work covered by and included in the Contract award and designated above, payment thereof to be made in the manner provided by the County in the sum of: One Hundred Ten Thousand Seven Hundred Dollars and 00/100 (\$110,700.00).
3. EQUAL EMPLOYMENT OPPORTUNITY: In connection with the carrying out of this project, the Contractor shall not discriminate against any employee, applicant for employment, or any other person because of race, color, religion, sex, national origin, ancestry, disability, age or marital status. The Contractor will take affirmative action to ensure that applicants are employed, and that employees are treated during employment, without regard to their race, color, religion, sex, national origin, ancestry, disability, age or marital status. Such action shall include, but not be limited to, the following: employment, upgrading, demotion or transfer; recruitment or recruitment advertising; layoff or termination; rates of pay or other compensation; and selection for training, including apprenticeship.
4. To the extent permitted by law, the County relinquishes control of the construction site to the Contractor and its subcontractors during the period of construction. The construction, placement of barricades, and posting of warning signs in the area of construction will be the responsibility of the Contractor. This shall include the placement of construction equipment and any obstacles which are created as a result of the construction project. The placement of barricades and warning signs shall be in compliance with the Manual on Uniform Control Devices, the 2011 City of Lincoln Standard Specifications for Municipal Construction, as supplemented by the 2007 Edition of the Standard Specifications of Highway Construction of the State of Nebraska, the Special Provisions, Supplementary Special Provisions, and all other supplementary documents to this Agreement. To the extent permitted by law, the Contractor expressly accepts control of the construction site, such control shall include, but not be limited to, barricades, signs, road crossings, warning signs, construction equipment and any obstacles created during construction of the project.
5. It is the express intent of the parties that this Agreement shall not create an employer-employee relationship. Employees of the Contractor shall not be deemed to be employees of the County and employees of the County shall not be deemed to be employees of the Contractor. The Contractor and the County shall be responsible to their respective employees for all salary and benefits. Neither the Contractor's employees nor the County's employees shall be entitled to any salary, wages, or benefits from the other party, including but not limited to overtime, vacation, retirement benefits, workers' compensation, sick leave or injury leave. Contractor shall also be responsible for maintaining workers' compensation insurance, unemployment insurance for its employees, and for payment of all federal, state, local and any other payroll taxes with respect to its employees' compensation.

6. Each party agrees to indemnify and hold harmless, to the fullest extent allowed by law, the other party and its principals, officers, and employees from and against all claims, demands, suits, actions, payments, liabilities, judgments and expenses (including court-ordered attorneys' fees), arising out of or resulting from the acts or omissions of their principals, officers, or employees in the performance of this Agreement. Liability includes any claims, damages, losses, and expenses arising out of or resulting from performance of this Agreement that results in any claim for damage whatsoever including any bodily injury, civil rights liability, sickness, disease, or damage to or destruction of tangible property, including the loss of use resulting therefrom. Further, each party shall maintain a policy or policies of insurance (or a self-insurance program), sufficient in coverage and amount to pay any judgments or related expenses from or in conjunction with any such claims. Nothing in this Agreement shall require either party to indemnify or hold harmless the other party from liability for the negligent or wrongful acts or omissions of said other party or its principals, officers, or employees.
7. This Contract shall be effective upon execution by both parties. The Work included in this Contract shall commence on October 1, 2018 (*or upon notice to proceed by the County*) and shall be completed on or before November 2, 2018 (*or within 32 calendar days*).
8. If any portion of this Agreement is held invalid, the remainder hereof shall not be affected thereby if such remainder would then continue to conform to the terms and requirements of applicable law.
9. GUARANTEE: A Performance and Labor and Material Payment Bond in the full amount of the Contract shall be required for all construction contracts.
10. In accordance with Neb. Rev. Stat. 4-108 through 4-114, the Contractor agrees to register with and use a federal immigration verification system, to determine the work eligibility status of new employees performing services within the state of Nebraska. A federal immigration verification system means the electronic verification of the work authorization program of the Illegal Immigration Reform and Immigrant Responsibility Act of 1996, 8 U.S.C. 1324 a, otherwise known as the E-Verify Program, or an equivalent federal program designated by the United States Department of Homeland Security or other federal agency authorized to verify the work eligibility status of a newly hired employee pursuant to the Immigration Reform and Control Act of 1986. The Contractor shall not discriminate against any employee or applicant for employment to be employed in the performance of this section pursuant to the requirements of state law and 8 U.S.C.A. 1324b. The Contractor shall require any subcontractor to comply with the provisions of this section.
11. This Contract Agreement, along with the Suppliers Response, Plans and the following Supplemental Contract Documents, attached hereto and incorporated by this reference, form this Contract:
 1. Instructions to Bidders
 2. Supplemental Instructions to Bidders
 3. Map
 4. Accepted Proposal of Contractor
 5. Contractor Work Resume Form
 6. Project Schedule Form
 7. Special Provisions
 8. Signing Plans
 9. Performance and Labor and Material Payment Bond
 10. Purchasing Agent Appointment
 11. Nebraska Resale or Exempt Sale Certificate
 12. Tax Assessment Form
 13. Employer Classification Act Instructions
 14. Employee Classification Act Affidavit
 15. Insurance Clause and Certificate

The Contractor and the County hereby agree that all the terms and conditions of this Contract shall be binding upon themselves, and their heirs, administrators, executors, legal and personal representatives, successors, and assigns.

IN WITNESS WHEREOF, the **Contractor** and the **County** do hereby execute this contract.

EXECUTION BY LANCASTER COUNTY, NEBRASKA

ATTEST:

BY THE BOARD OF COUNTY COMMISSIONERS OF
LANCASTER COUNTY, NEBRASKA

County Clerk

Contract and Bond Approved as to Form

this _____ day of _____, _____

Deputy County Attorney

EXECUTION BY CONTRACTOR

IF A CORPORATION:

SCONDELLER CONSTRUCTION
Name of Corporation

51722 GRAZING RIVER AVENUE
(Address) WIXOM, MI 48393

ATTEST:

Secretary

Steph Scodeller Secretary

By: _____
Duly Authorized Official

E.S. DWYER, VICE PRES.
Legal Title of Official

IF OTHER TYPE OF ORGANIZATION:

Name of Organization

Type of Organization

Address)

By: _____
Member

By: _____
Member

IF AN INDIVIDUAL:

Name

Address

Signature

INSTRUCTIONS TO BIDDERS

LANCASTER COUNTY, NEBRASKA

PURCHASING DIVISION

E-Bid

1. BIDDING PROCEDURE

- 1.1 Sealed bid, (formal and informal), subject to Instructions and General Conditions and any special conditions set forth herein, will be received in the office of the Purchasing Division, 440 So. 8th St., Lincoln, NE 68508, until the bid closing date and time indicated for furnishing Lancaster County, hereinafter referred to as "County", the materials, supplies, equipment or services shown in the electronic bid request.
- 1.2 Bidders shall use the electronic bid system for submitting bids and must complete all required fields. If you do not care to bid, please respond to the bid request and note your reason.
- 1.3 Identify the item you will furnish by brand or manufacturer's name and catalog numbers. Also furnish specifications and descriptive literature if not bidding the specific manufacturer or model as listed in the specifications.
- 1.4 Any person submitting a bid for a firm, corporation, or other organization must show evidence of his authority so to bind such firm, corporation, or organization.
- 1.5 Bids received after the time and date established for receiving bids will be rejected.
- 1.6 The Bidders and public are invited, but not required, to attend the formal opening of bids. At the opening, prices will be displayed electronically and/or read aloud to the public. The pricing is also available for immediate viewing on-line. No decisions related to an award of a contract or purchase order will be made at the opening.

2. BID SECURITY

- 2.1 Bid security, as a guarantee of good faith, in the form of a certified check, cashier's check, or Bidder's bond, may be required to be submitted with this bid document, as indicated on the bid.
 - 2.1.1 Bid security, if required, shall be in the amount specified on the bid. The bid security must be scanned and attached to the "Response Attachments" section of your response or it can be faxed to the Purchasing office at 402-441-6513. The original bid security should then be sent or delivered to the office of the Purchasing Division, 440 S. 8th St., Ste. 200, Lincoln, NE 68508 within three (3) days of bid closing.
 - 2.1.2 If bid security is not received in the Purchasing Division as stated above, the vendor may be determined to be non-responsive.
- 2.2 If alternate bids are submitted, only one bid security will be required, provided the bid security is based on the amount of the highest gross bid.
- 2.3 Such bid security will be returned to the unsuccessful Bidders when the award of bid is made.
- 2.4 Bid security will be returned to the successful Bidder(s) as follows:
 - 2.4.1 For single order bids with specified quantities: upon the delivery of all equipment or merchandise, and upon final acceptance by the County.
 - 2.4.2 For all other contracts: upon approval by the County of the executed contract and bonds.
- 2.5 County shall have the right to retain the bid security of Bidders to whom an award is being considered until either:
 - 2.5.1 A contract has been executed and bonds have been furnished.
 - 2.5.2 The specified time has elapsed so that the bids may be withdrawn.
 - 2.5.3 All bids have been rejected.
- 2.6 Bid security will be forfeited to the County as full liquidated damages, but not as a penalty, for any of the following reasons, as pertains to this bidding document:
 - 2.6.1 If the Bidder fails or refuses to enter into a contract on forms provided by the County, and/or if the Bidder fails to provide sufficient bonds or insurance within the time period as established in this bidding document.

3. BIDDER'S REPRESENTATION

- 3.1 Each Bidder by electronic signature and submitting a bid, represents that the Bidder has read and understands the bidding documents, the bid attributes, the bid attachments, and the bid has been submitted in accordance therewith.
- 3.2 Each Bidder for services further represents that the Bidder has examined and is familiar with the local conditions under which the work is to be done and has correlated the observations with the requirements of the bid documents.

4. INDEPENDENT PRICE DETERMINATION

- 4.1 By submitting this bid, the Bidder certifies that the prices in this bid have been arrived at independently, without consultation, communication or agreement, for the purpose of restricting competition, as to any matter relating to such prices with any other Bidder or with any competitor; unless otherwise required by law, the prices which have been quoted in this bid have not been knowingly disclosed by the Bidder prior to bid opening directly or indirectly to any other Bidder or to any competitor; no attempt has been made, or will be made, by the Bidder to induce any person or firm to submit, or not to submit, a bid for the purpose of restricting competition.

5. CLARIFICATION OF SPECIFICATION DOCUMENTS

- 5.1 Bidders shall promptly notify the Purchasing Agent or designee of any ambiguity, inconsistency or error which they may discover upon examination of the bidding documents.
- 5.2 Bidders desiring clarification or interpretation of the bidding documents for formal bids shall make a written request which must reach the Purchasing Agent or designee at least five (5) calendar days prior to the date and time for receipt of formal bids.
- 5.3 Changes made to the bidding documents will be issued electronically. All vendors registered for that bid will be notified of the addendum. Subsequent Bidders will only receive the bid with the addendum included.
- 5.4 Oral interpretations or changes to the bidding documents made in any manner other than written form, will not be binding on the County; and Bidders shall not rely upon such interpretations or changes.

6. ADDENDA

- 6.1 Addenda are instruments issued by the County prior to the date for receipt of bids which modify or interpret the bidding document by addition, deletion, clarification or correction.
- 6.2 Addenda notification will be made available to all registered vendors immediately via e-mail for inspection on-line.
- 6.3 No formal bid addendums will be issued later than forty-eight (48) hours prior to the date and time for receipt of formal bids, except an addendum withdrawing the invitation to bid, or an addendum which includes postponement of the bid.

7. ANTI-LOBBYING PROVISION

- 7.1 During the period between the advertised date and the contract award, Bidders, including their agents and representatives, shall not directly discuss or promote their bid with any member of the County Board or County staff except in the course of County-sponsored inquiries, briefings, interviews, or presentations, unless requested by the County.

8. BRAND NAMES

- 8.1 Wherever in the specifications or bid that brand names, manufacturer, trade name, or catalog numbers are specified, it is for the purpose of establishing a grade or quality of material only; and the term "or equal" is deemed to follow.
- 8.2 It is the Bidder's responsibility to identify any alternate items offered in the bid, and prove to the satisfaction of the County that said item is equal to, or better than, the product specified.
- 8.3 Bids for alternate items shall be stated in the appropriate space on the E-Bid form. Bidders MUST attach to its bid documents in the Vendor Attachment Section of the E-Bid, a statement identifying the manufacturer and brand name of each proposed alternate, plus a complete description of the alternate items including illustrations, performance test data and any other information necessary for an evaluation.
- 8.4 The Bidder must indicate any variances and explain by item number from the bidding document no matter how slight.
- 8.5 If variations are not stated in the bid, it will be assumed that the item being bid fully complies with the County's bidding documents.

9. DEMONSTRATIONS/SAMPLES

- 9.1 Bidders shall demonstrate the exact item(s) proposed within seven (7) calendar days from receipt of such request from the County.
- 9.2 Such demonstration can be at the County delivery location or a surrounding community.
- 9.3 If items are small and mailable, and the Bidder is proposing an alternate product, the Bidder shall supply a sample of the exact item. Samples will be returned at Bidder's expense after receipt by the County of acceptable goods. The Bidder must indicate how samples are to be returned.

10. DELIVERY (Non-Construction)

- 10.1 Each Bidder shall state on the bid the date upon which it can make delivery of all equipment or merchandise. Time required for delivery is hereby made an essential element of the bid.
- 10.2 The County reserves the right to cancel orders, or any part thereof, without obligation, if delivery is not made within the time(s) specified on the bid.
- 10.3 All bids shall be based upon inside delivery of the equipment or merchandise F.O.B. to the County at the location specified by the County, with all transportation charges paid.
- 10.4 At the time of delivery, a designated Lancaster County employee will sign the invoice/packing slip. The signature will only indicate that the order has been received and the items actually delivered agree with the delivery invoice. This signature does not indicate all items meet specifications, were received in good condition and/or that there is not possible hidden damage or shortages.

11. WARRANTIES, GUARANTEES AND MAINTENANCE

- 11.1 Copies of the following documents, if requested, shall accompany the bid proposal for all items being bid:
 - 11.1.1 Manufacturer's warranties and/or guarantees.
 - 11.1.2 Bidder's maintenance policies and associated costs.
- 11.2 As a minimum requirement of the County, the Bidder will guarantee in writing that any defective components discovered within a one (1) year period after the date of acceptance shall be replaced at no expense to the County. Replacement parts of defective components shall be shipped at no cost to the County. Shipping costs for defective parts required to be returned to the Bidder shall be paid by the Bidder.

12. ACCEPTANCE OF MATERIAL

- 12.1 All components used in the manufacture or construction of materials, supplies and equipment, and all finished materials, shall be new, the latest make/model, of the best quality, and the highest grade workmanship.
- 12.2 Material delivered under this bid shall remain the property of the Bidder until:
 - 12.2.1 A physical inspection and actual usage of the material is made and found to be acceptable to the County; and
 - 12.2.2 Material is determined to be in full compliance with the bidding documents and accepted bid.
- 12.3 In the event the delivered material is found to be defective or does not conform to the bidding documents and accepted bid, the County reserves the right to cancel the order upon written notice to the Bidder and return materials to the Bidder at Bidder's expense.
- 12.4 Awarded Bidder shall be required to furnish title to the material, free and clear of all liens and encumbrances, issued in the name of the Lancaster County, Nebraska, as required by the bidding documents or purchase orders.
- 12.5 Awarded Bidder's advertising decals, stickers or other signs shall not be affixed to equipment. Vehicle mud flaps shall be installed blank side out with no advertisements. Manufacturer's standard production forgings, stampings, nameplates and logos are acceptable.

13. BID EVALUATION AND AWARD

- 13.1 The electronic signature shall be considered an offer on the part of the Bidder. Such offer shall be deemed accepted upon issuance by the County of purchase orders, contract award notifications, or other contract documents appropriate to the work.
- 13.2 No bid shall be modified or withdrawn for a period of ninety (90) calendar days after the time and date established for receiving bids, and each Bidder so agrees in submitting the bid.
- 13.3 In case of a discrepancy between the unit prices and their extensions, the unit prices shall govern.
- 13.4 The bid will be awarded to the lowest responsive, responsible Bidder whose bid will be most advantageous to the County, and as the County deems will best serve the requirements and interests of the County.
- 13.5 The County reserves the right to accept or reject any or all bids; to request rebids; to award bids item-by-item, with or without alternates, by groups, or "lump sum"; to waive irregularities and technicalities in bids; such as shall best serve the requirements and interests of the County.
- 13.6 In order to determine if the Bidder has the experience, qualification, resources and necessary attributes to provide the quality workmanship, materials and management required by the plans and specifications, the Bidder may be required to complete and submit additional information as deemed necessary by the County. Failure to provide the information requested to make this determination may be grounds for a declaration of non-responsive with respect to the Bidder.
- 13.7 The County reserves the right to reject irregular bids that contain unauthorized additions, conditions, alternate bids, or irregularities that make the bid incomplete, indefinite or ambiguous.
- 13.8 Any governmental agency may piggyback on any contract entered into from this bid.

14. INDEMNIFICATION

- 14.1 The Bidder shall indemnify and hold harmless, to the fullest extent allowed by law, the County, its agents, officers, employees and representatives from and against all claims, demands, suits, actions, payments, liability, judgements and expenses (including court-ordered attorney's fees), arising out of or resulting from the performance of the contract that results in bodily injury, sickness, disease, death, civil rights liability, or injury to or destruction of tangible property, including the loss of use resulting therefrom, and that are caused in whole or in part by the Bidder, its employees, agents, any subcontractor, anyone directly or indirectly employed by them, or anyone for whose acts any of them may be liable. This section will not require the Bidder to indemnify or hold harmless the County for any losses, claims, damages and expenses arising out of or resulting from the sole negligence of the County, its agents, employees, or representatives.
- 14.2 In any and all claims against the County or any of its members, officers or employees by an employee of the Bidder, any subcontractor, anyone directly or indirectly employed by any of them or by anyone for whose acts made by any of them may be liable, the indemnification obligation under paragraph 14.1 shall not be limited in any way by any limitation of the amount or type of damages, compensation or benefits payable by or for the Bidder or any subcontractor under worker's compensation acts, disability benefit acts or other employee benefit acts.

15. TERMS OF PAYMENT

- 15.1 Unless stated otherwise, the County will begin processing payment within thirty (30) calendar days after all labor has been performed and all equipment or other merchandise has been delivered, and all such labor and equipment and other materials have met all contract specifications.

16. LAWS

- 16.1 The laws of the State of Nebraska shall govern the rights, obligations, and remedies of the parties under this bid and any contract reached as a result of this process.
- 16.2 Bidder agrees to abide by all applicable local, state and federal laws and regulations concerning the handling and disclosure of private and confidential information concerning individuals and corporations as to inventions, copyrights, patents and patent rights.
- 16.3 The Bidder agrees to hold the County harmless from any claims resulting from the Bidder's unlawful disclosure or use of private or confidential information.

17. EQUIPMENT TAX ASSESSMENT

17.1 Any bid for public improvement shall comply with Nebraska Revised Statutes 77-1323 and 77-1324. Indicating; every person, partnership, limited liability company, association or corporation furnishing labor or material in the repair, alteration, improvement, erection, or construction of any public improvement shall sign a certified statement which will accompany the contract. The certified statement shall state, stating that all equipment to be used on the project, except that acquired since the assessment date, has been assessed for taxation for the current year, giving the county where assessed.

18. AFFIRMATIVE ACTION

- 18.1 Each Bidder agrees that it will not discriminate against any employee or applicant for employment because of race, color, religion, sex, national origin, ancestry, disability, age, or marital status.
- 18.2 The successful Bidder will be required to comply with the provisions of the County's Affirmative Action Policy.
- 18.3 The Equal Opportunity Officer will determine compliance or non-compliance with the County's Affirmative Action Policy upon a complete and substantial review of successful Bidder's equal opportunity policies, procedures and practices.
- 18.4 The County provides equal opportunity for all Bidders and encourages minority businesses, women's businesses and locally owned business enterprises to participate in our bidding process.

19. INSURANCE

19.1 All Bidders shall take special notice of the insurance provisions required for all County contracts (see Insurance Clause for All County Contracts).

20. EXECUTION OF CONTRACT

20.1 Depending on the type of service provided, one of the following methods will be employed. The method applicable to this contract will be checked below:

- a. PURCHASE ORDER, unless otherwise noted.
1. This contract shall consist of a Lancaster County Purchase Order.
 2. A copy of the Bidder's bid response (or referenced bid number) attached and that the same, in all particulars, becomes the contract between the parties hereto: that both parties thereby accept and agree to the terms and conditions of said bid documents.
- b. CONTRACT, unless otherwise noted.
1. County will furnish 2 copies of the Contract to the successful Bidder who shall prepare attachments as required. Insurance as evidenced by a Certificate of Insurance (as required), surety bonds properly executed (as required), and Contract signed and dated.
 2. The prepared documents shall be returned to the Purchasing Office within 10 days (unless otherwise noted).
 3. The County will sign and date the Contract and submit the Contract to the County Board of Commissioners for approval and signature.
 4. Upon approval and signature, the County will return one copy to the successful Bidder.

21. TAXES AND TAX EXEMPTION CERTIFICATE

21.1 The County is generally exempt from any taxes imposed by the State or Federal Government. A Tax Exemption Certificate will be provided as applicable.

22. E-VERIFY

22.1 In accordance with Neb. Rev. Stat. 4-108 through 4-114, the contractor agrees to register with and use a federal immigration verification system, to determine the work eligibility status of new employees performing services within the state of Nebraska. A federal immigration verification system means the electronic verification of the work authorization program of the Illegal Immigration Reform and Immigrant Responsibility Act of 1996, 8 U.S.C. 1324 a, otherwise known as the E-Verify Program, or an equivalent federal program designated by the United States Department of Homeland Security or other federal agency authorized to verify the work eligibility status of a newly hired employee pursuant to the Immigration Reform and Control Act of 1986. The Contractor shall not discriminate against any employee or applicant for employment to be employed in the performance of this section pursuant to the requirements of state law and 8 U.S.C.A 1324b. The contractor shall require any subcontractor to comply with the provisions of this section. For information on the E-Verify Program, go to www.uscis.gov/everify.

SUPPLEMENTAL INSTRUCTIONS TO BIDDERS

Lancaster County Engineering Department Road and Bridge Construction Projects

This project shall be subject to and performed in accordance with the Instructions to Bidders, and with the revisions and amendments listed below. In the event of a conflict with the Instructions to Bidders, the Supplemental Instructions listed below shall control and take precedence. Contractors must register as a vendor with City/County Purchasing to receive electronic bid (E-Bid) notices and must submit their bid via the E-Bid system. Please call (402) 441-8103 or e-mail purchasing@lincoln.ne.gov for assistance.

1. Section 1.1 shall be amended as follows: Sealed bids, formal and informal, are subject to the Instructions and General Conditions, and any Special Conditions set forth herein, and will be received in the Office of the Purchasing Agent, 440 So. 8th St., Lincoln, NE 68508, until the bid closing date and time indicated for furnishing Lancaster County the materials, supplies, equipment or services shown in the written specifications and electronic bid request.
2. Section 1.3 is not applicable to this project.
3. Section 5.1 shall be amended as follows: Bidders shall promptly notify the Lancaster County Engineering Department of any ambiguity, inconsistency, or error which they may discover upon examination of the specification documents.
4. Section 8 is not applicable to this project.
5. Section 9 is not applicable to this project.
6. Section 10 is not applicable to this project.
7. Section 11 is not applicable to this project.
8. Section 12 is not applicable to this project.
9. Section 13.5 shall be amended as follows: It is the intent of this bid to receive proposals and award a contract for all the construction work shown on the plans. However, the County reserves the right and will be free to evaluate the proposals based on the low bids for a combination of any or all parts as the County sees fit or desires. The bidder must bid all items on the proposal(s). All work awarded will be awarded to one and only one bidder.
10. Section 13.8 is not applicable to this project.
11. Section 15 is not applicable to this project.
12. The following sections are added to the Instructions to Bidders:

STANDARD SPECIFICATIONS. The work as detailed on the plans shall be completed in accordance with the requirements of the Nebraska Department of Road's 2007 Standard Specifications for Highway Construction. The Nebraska Department of Road's 2007 Standard Specifications for Highway Construction (NDOR Standard Specifications), including all amendments, Supplemental Specifications and additions thereto effective at the date of the contract, the Special Provisions, plans, and all supplementary documents are essential parts of the contract.

BID DOCUMENTS. Copies of the Proposal, Specifications (Standard Specifications, Special Provisions, General Requirements, etc.), Plans (if required) and other document forms may be viewed at the office of the County Engineer or may be downloaded via the City/County e-bid process. Bidders are required to examine the same and satisfy themselves that all requirements are fully understood. Bidders are encouraged to personally inspect the location of the project upon which they are bidding.

QUALIFICATION OF BIDDERS. The bidder shall either be currently qualified with the Nebraska State Department of Roads for the group or groups of work to be bid on this contract or the bidder shall provide proof of responsibility to the satisfaction of Lancaster County. Generally, proof of responsibility shall consist of providing a brief resume of work successfully completed by the bidder that is similar to the type of work being bid. Additional information may be required by the County in order to determine a prospective bidder's qualifications.

All bidders The Contractor will complete and attach this form to the E-Bid in the Response Attachment section IF it has not done any work for Lancaster County similar in nature to that of this bid in the last three years.

SUBLETTING OR ASSIGNING THE CONTRACT. The bidder's attention is directed to Section 108.01 of the Standard Specifications regarding assignment or subletting contracts.

Site Location

Crack Sealing Bituminous Surfacing

Project No. 18-22

Lancaster County, Nebraska

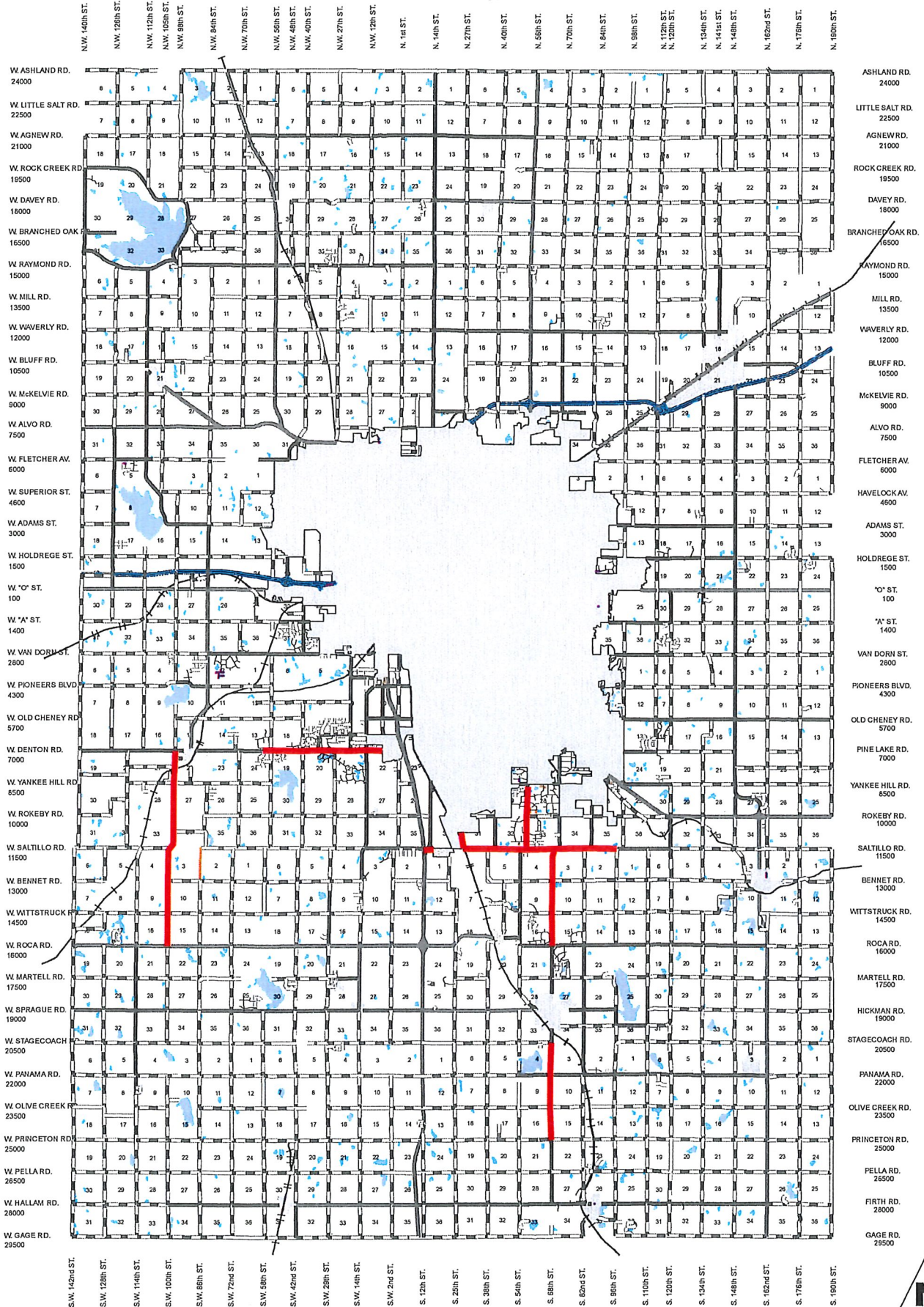

City of Lincoln/Lancaster County (Lincoln Purchasing) Supplier Response

Bid Information		Contact Information		Ship to Information
Bid Creator	Robert Walla Purchasing Agent	Address	Purchasing\City & County	Address
Email	rwalla@lincoln.ne.gov		440 S. 8th St.	
Phone	1 (402) 441-8309 x		Lincoln, NE 68508	Contact
Fax	1 (402) 441-6513 x	Contact	Robert Walla - Purchasing Agent	Department
Bid Number	18-141			Building
Title	CRACK SEALING BITUMINOUS SURFACING, PROJECT NO. 18-22 (Rebid) (Co. Engineer))	Department		Floor/Room
		Building		Telephone
Bid Type	Bid	Floor/Room		Fax
Issue Date	5/24/2018 01:39 PM (CT)	Telephone	(402) 441-8309 x	Email
Close Date	6/13/2018 12:00:00 PM (CT)	Fax		
		Email	rwalla@lincoln.ne.gov	

Supplier Information

Company	Scodeller Construction
Address	51722 Grand River
	Wixom, MI 48393
Contact	Michael Lierman
Department	
Building	
Floor/Room	
Telephone	(248) 374-1102
Fax	(248) 374-1109
Email	michael@scodeller.com
Submitted	6/13/2018 10:25:31 AM (CT)
Total	\$110,700.00

By submitting your response, you certify that you are authorized to represent and bind your company.

Signature Michael Lierman

Email michael@scodeller.com

Supplier Notes

Bid Notes

If you need assistance in preparing your bid, contact our office at 402-441-8103 to set up a training session in Purchasing or assistance over the phone.

Bid Activities

Date	Name	Description
6/13/2018 12:00:00 PM (CT)	Intent to Bid - General Contractor Listing	If you intend to bid as a Sub Contractor, select "No, I do not intend to respond to this opportunity" in the Response Intent Box, click Save. Click "Intent" a second time, select "Yes, I intend to respond to this opportunity" in the Response Intent Box, click Save.

Bid Messages

Bid Attributes

Please review the following and respond where necessary

#	Name	Note	Response
1	Instructions to Bidders	I acknowledge reading and understanding the Instructions to Bidders.	Yes
2	Supplemental Instructions to Bidders	I acknowledge reading and understanding the Supplemental Instructions to Bidders.	Yes
3	Insurance Requirements and Endorsements	<p>Vendor agrees to the applicable terms listed in the Insurance Clause document including the submission of the Certificate of ACCORD and the following endorsements:</p> <ol style="list-style-type: none"> 1. Additional Insured - Lancaster County. 2. Workers Compensation - Waiver of Subrogation. 3. 30 Day Cancellation Notice <p>Insurance Certificate and required Endorsements are required at time of contract execution by the vendor.</p> <p>Vendors are strongly encouraged to send the insurance requirements and endorsement information to their insurance agent prior to bid close in order to expedite the contract execution process.</p>	Yes
4	NDOR Standard Specs for Hwy Construction	I acknowledge reading and understanding the current Nebraska Department of Road's Standard Specifications for Highway Construction Supplemental Specifications to the Standard Specifications for Highway Construction, view at: http://www.dor.state.ne.us/ref-man/	Yes
5	Specifications	I acknowledge reading and understanding the specifications.	Yes
6	Drawings	I acknowledge reading and understanding the Project Drawings.	Yes
7	Work Resume Form	I have attached my Contractor Work Resume Form to this bid if my company has not completed work for Lancaster County in the last 3 years.	Yes
8	Project Schedule Form	I have attached my Project Schedule Form to this bid.	Yes
9	Barricade and Detour Plans	I acknowledge reading and understanding the Barricade Plans and Detour Plans.	Yes
10	Sample Contract	I acknowledge reading and understanding the Contract Agreement Forms.	Yes
11	Bonds	I acknowledge that the Performance Bond and Payment Bond in the amount of 100% of the Contract amount will be required with the signed contract upon award of this job.	Yes

12	Tax Exempt Certification Forms	Materials being purchased in this bid are tax exempt and unit prices are reflected as such. A Purchasing Agent Appointment form and a Exempt Sales Certificate form shall be issued with contract documents. (Note: State Tax Law does not provide for sales tax exemption for proprietary functions for government, thereby excluding the purchases of pipes to be installed in water lines and purchase of water meters.)	Yes
13	Tax Assessment Form	I acknowledge reading and understanding the Tax Assessment Form will be required with the contract.	Yes
14	Bid Bond Submission	I acknowledge and understand that my bid will not be considered unless a bid bond or certified check in the sum of five percent (5%) of the total amount of the bid is made payable to the order of the County Treasurer as a guarantee of good faith prior to the bid opening. The bid security may be scanned and attached to the 'Response Attachments' section of your response or faxed to the Purchasing Office (402)441-6513. The original bond/check must then be received in the Purchasing Office, 440 S. 8th Street, Ste. 200, Lincoln, NE 68508 within three (3) days of bid closing. YOU MUST INDICATE YOUR METHOD OF BID BOND SUBMISSION IN BOX TO RIGHT!	I have scanned and attached my bid bond.
15	Project Dates	The Contractor agrees that the Work in this Contract shall commence on October 1, 2018 (or upon notice to proceed by the County) and shall be completed on or before November 2, 2018 (or within 32 calendar days).	Yes
16	Unit Price Spreadsheets	I acknowledge the Excel spreadsheets are attached to this bid in the Response Attachment Section. The unit price of the Excel Spreadsheet takes precedence over the total submitted in Line Items.	Yes
17	Employee Class Act Affidavit	I acknowledge if awarded the contract I will abide by the law, notarize and attach the Employee Classification Act Affidavit to my contract.	Yes
18	Recycling of Corrugated Cardboard	I acknowledge that I must comply with the City of Lincoln recycling regulations which includes a ban of all corrugated cardboard from the City Landfill effective April 1, 2018. Vendors are encouraged to utilize recycling sites located throughout the city of Lincoln to dispose of corrugated cardboard.	Yes
19	Contact	Name of person submitting this bid:	Michael Lierman
20	Electronic Signature	Please check here for your electronic signature.	Yes

21 U.S. Citizenship Attestation

Is your company legally considered an Individual or Sole Proprietor: YES or NO NO

As a Vendor who is legally considered an Individual or a Sole Proprietor I hereby understand and agree to comply with the requirements of the United States Citizenship Attestation Form, available at:
<http://www.sos.ne.gov/business/notary/citizenforminfo.html>

All awarded Vendors who are legally considered an Individual or a Sole Proprietor must complete the form and submit it with contract documents at time of execution.

If a Vendor indicates on such attestation form that he or she is a qualified alien, the Vendor agrees to provide the US Citizenship and Immigration Services documentation required to verify the Vendor's lawful presence in the United States using the Systematic Alien Verification for Entitlements (SAVE) Program.

Vendor further understands and agrees that lawful presence in the United States is required and the Vendor may be disqualified or the Contract terminated if such lawful presence cannot be verified as required by Neb. Rev. Stat. 4-108.

Line Items

#	Qty	UOM	Description	Response
1	1	Lump Sum	CRACK SEALING BITUMINOUS SURFACING, PROJECT NO. 18-22 (Rebid) -- Total Lump Sum attached spreadsheet.	\$110,700.00

Item Notes: Fill out the itemized Excel spreadsheet attached below. Attach completed spreadsheet on the 'Response Attachments' of your response.

Supplier Notes:

Response Total: \$110,700.00

Contractor Name **Scodeller Construction**

Line No.	Description	Estimated Quantity	Unit	Unit Price	Amount
	Project No. 18-22				
	Crack Sealing Bituminous Surfacing				
1	Crack Sealing Bituminous Surfacing	120,000.00	LF	\$0.90	\$108,000.00
2	Construction Signs	150.00	SignDays	\$8.00	\$1,200.00
3	Furnishing and Operating Pilot Vehicle	20.00	Days	\$15.00	\$300.00
4	Flagging	40.00	Days	\$5.00	\$200.00
5	Mobilization	1.00	LumpSum	\$1,000.00	\$1,000.00
	Total				\$110,700.00

CONTRACTOR WORK RESUME FORM
FOR
LANCASTER COUNTY, NEBRASKA

PROJECT NO. 18-22

CRACK SEALING BITUMINOUS SURFACING

The following is a list of projects recently completed by Scodeller Construction which are thought to be similar in nature to the work required in the aforementioned project:
(Firm Name)

1. ST. Louis Airport Joint seal Contract 70814
Owner Project Name and/or Number
4700 St. Andrew Ln 190,000 6-6-18
Street Address Contract Amount Completion Date
Bridgeton MD 63044
City State Zip
Vaughn Desha (314) 551-5352
Name Owner's Representative Phone

Brief Description of Work
Joint cleaning and sealing of taxiway and runway

2. City OF LINCOLN / STATE OF NEB NH-180-9(3)
Owner Project Name and/or Number
I-180 Cornhusker to US-34 46,500 MAY 2018
Street Address Contract Amount Completion Date
Lincoln NE
City State Zip
Duwayne Knutson (402) 471-4567
Name Owner's Representative Phone

Brief Description of Work
Crack sealing I-80 - Concrete, Asphalt, traffic Control

3. STATE OF Nebraska
Owner

NH-680-9(38)
Project Name and/or Number

I-680, Fort St. - MD river
Street Address

143,000
Contract Amount

MAY 2018
Completion Date

Omaha NE 68145
City State Zip

MD Farvati (402) 595-2534
Name Owner's Representative Phone

Brief Description of Work

Crack sealing bituminous surfacing I-680

4. STATE OF Arkansas
Owner

STATE HWY 65 B / 02.0647
Project Name and/or Number

Bryant St. - Convention Center Dr.
Street Address

309,183
Contract Amount

MAY 2018
Completion Date

Pine Bluff AR 72206
City State Zip

Tim Bennett (501) 539-0827
Name Owner's Representative Phone

Brief Description of Work

Joint sealing STATE Highway 65 Pine bluff AR

The Contractor will complete and attach this form to the E-Bid in the Response Attachment section IF it has not done any work for Lancaster County similar in nature to that of this bid in the last three years.

PROJECT SCHEDULE
FOR
LANCASTER COUNTY, NEBRASKA

PROJECT NO. 18-22

CRACK SEALING BITUMINOUS SURFACING

The following is the sequence that the bidder proposes to use to complete the work under this Contract. The dates specified shall be considered approximate and is furnished to the County, property owners, utility companies and emergency service organizations for informational use. Bidder shall estimate the chronological order of the work and report accordingly.

WORK DESCRIPTION	ESTIMATED BEGIN DATE	ESTIMATED COMPLETION DATE
1. <u>Crack seal bituminous</u>	<u>10-1-18</u>	<u>10-3-18</u>
2. <u>Crack seal bituminous</u>	<u>10-4-18</u>	<u>10-6-18</u>
3. <u>Crack seal bituminous</u>	<u>10-8-18</u>	<u>10-10-18</u>
4. <u>Crack seal bituminous</u>	<u>10-11-18</u>	<u>10-16-18</u>
5. <u>Crack seal bituminous</u>	<u>10-17-18</u>	<u>10-22-18</u>
6. <u>Crack Seal bituminous</u>	<u>10-23-18</u>	<u>10-29-18</u>
7. <u>Crack seal bituminous</u>	<u>10-30-18</u>	<u>11-2-18</u>

The Contractor will attach this form to the E-Bid in the "Response Attachment" section

GENERAL INFORMATION

The following are revisions, amendments and/or supplements to the Standard Specifications:

Section 101, Article 101.0317

Commission. Shall mean the Board of County Commissioners of Lancaster County, Nebraska.

Section 101, Article 101.0321

The word "Pre-Qualified" shall be eliminated from the definition of the term Contractor.

Section 101, Article 101.0328

Department. Shall mean the Lancaster County Engineering Department.

Section 101, Article 101.0335

Engineer. Shall mean the Lancaster County Engineer.

Section 101, Article 101.0349

The word "Pre-Qualified" shall be eliminated from the definition of the term Letting.

Section 101, Article 101.0383

State. Shall mean Lancaster County, Nebraska.

Section 102, Article 102.01

This section of the Standard Specification is null and void.

Section 102, Article 102.02

This section of the Standard Specification is null and void and will be replaced with the following:

Qualification of bidders with the State of Nebraska on County projects is desirable but not mandatory. If in the opinion of the County Engineer a bidders' experience, equipment or financial condition is in doubt, he may request and the bidders will provide information documenting the bidder qualifications prior to awarding a contract to said bidder.

Section 102, Article 102.05

This section of the Standard Specification is null and void (see E.E.O. requirements in Instructions to Bidders).

Section 102, Article 102.06

This section of the Standard Specification is null and void.

Section 102, Article 102.08

This section of the Standard Specification is null and void.

Section 102, Article 102.10 Paragraphs 1 and 2

These sections of the Standard Specification are null and void and will be replaced with the following:

All bids will be submitted using the City of Lincoln/Lancaster County Purchasing Agents' e-bid system. Facsimile or e-mail bids are not acceptable.

Section 102, Article 102.11 Paragraphs 1(b), 1(c), 1(e), 1(f), 1(g), 1(h), and 1(l).

These sections of the Standard Specifications are null and void.

Section 102, Article 102.12 Paragraph 2(a)

The sentence which references "Annual Bid Bond" is null and void.

Section 102, Article 102.12

This section of the Standard Specifications is null and void and will be replaced with the requirements in Section 1 of the Instructions to Bidders.

Section 102, Article 102.15

This section of the Standard Specifications is null and void and will be replaced with the requirements in Section 2 of the Instructions to Bidders.

Section 103, Article 103.01

The reference to the "Director" in the first sentence will mean Lancaster County Board of Commissioners. The reference to "Thirty Days" in the second sentence will be amended to 90 days.

SPECIAL PROVISIONS FOR PROJECT NO. 18-22; CRACK SEALING BITUMINOUS SURFACING
Page 2

Section 103, Article 103.04

This section of the Standard Specifications is null and void and will be replaced with the Paragraph titled "Performance, Labor, and Material Payment Bond" in these Supplemental Special Provisions.

Section 103, Article 103.05

This section of the Standard Specifications is null and void and will be replaced with Paragraph 20 of the Instructions to bidders.

Section 103, Article 103.06 Paragraph 1(a) and 1(b)

This section of the Standard Specifications is null and void and will be replaced with Paragraph 20 of the Instructions to Bidders.

Section 103, Article 103.06 Paragraph 2(b)

This section of the Standard Specification will be amended to read as follows:

- b. Proceed with the execution of the contract after the 10 day period when all required documents have been correctly submitted.

Section 105, Article 105.02 Paragraph 7

The address for submittal of shop drawings and working drawings will be amended to:

Lancaster County Engineering Department
444 Cherrycreek Road, Bldg "C"
Lincoln, NE 68528
Attn: Shop Drawings

Section 107, Article 107.12 This section of the Standard Specification is null and void.

Section 107, Article 107.13

The insurance coverages and limitations specified in this portion of the Standard Specification will be superseded by the form entitled "Insurance Clause for all County Contracts". All other requirements of this portion of the Standard Specification will remain unchanged.

DELIVERY (Construction)

All bids shall be based on the delivery schedule specified in the Special Provisions and/or Project Schedule Form. Time required for delivery of labor, materials, services, etc... as specified above is hereby made an essential element of the bid.

CONTRACT TIME PERIOD

The bidder proposes to furnish all necessary equipment, tools, machinery, apparatus, and other means of construction; to do all work and to furnish all materials and labor necessary to complete the work in accordance with the Plans, Specifications, and Special Provisions now on file in the office of the Lancaster County Engineer; to commence said work on October 1, 2018, and to complete all work on or before November 2, 2018. This project will be considered a calendar day project.

A contractor may begin work on the contract before the date specified herein, provided the contractor has received a notice to proceed from the County, such change is acceptable to the County Engineer, and the contractor has received written permission from the County to do so.

PROPOSAL EVALUATION

The unit prices specified herein shall prevail when evaluating the proposals to determine the successful bidder. Should an error be discovered in the estimated quantities during the advertisement period, every effort will be made to issue an addendum correcting the discrepancy. If, in the opinion of the County Engineer an addendum cannot be issued prior to the filing of the proposals, the County reserves the right to evaluate the proposals based on the known quantities at the time the proposals are opened.

BID BOND

The bidder will furnish a Bidder's Bond for not less than five percent (5%) of the total bid made payable to the County Treasurer of Lancaster County, Nebraska, which is to be retained as liquidated damages in case the bidder fails to enter into a Contract with sufficient bond for the full amount of the Contract price within ten (10) calendar days from the date of the award of the Contract to the bidder.

PERFORMANCE, LABOR, AND MATERIAL PAYMENT BOND. Within ten (10) calendar days after the award of the bid, the successful bidder must execute a written contract between the bidder and the County; such contract will incorporate the County's contract documents and be on forms provided by the County. Failure to enter into such a contract with the County within such time period will cause a forfeiture of bidder's bid security to the County as fully liquidated damages. Also within such time period, the successful bidder must furnish on forms provided by the County a Performance and Labor and Material Payment Bond in the sum of one hundred percent (100%) of the contract price, executed by the bidder and a corporate surety company authorized to transact business in the State of Nebraska. Such bond shall be conditioned upon the faithful performance of all terms and conditions of the contract documents, including the holding harmless of the County from failure to do so and including the making good of any and all guarantees which the contract documents may require; and, such bond shall be further conditioned upon the payment of all laborers and materialmen who provide labor, materials, etc. actually used or rented in the performance of the contract, including insurance premiums and interest.

SALE TAX EXEMPT STATUS

The Contractor is hereby advised that this project is sales tax exempt. The Contractor will be issued a Purchasing Agent Appointment and Sales Tax Exempt Certificate for the work on this project.

RETAINED EARNINGS

Section 109.07, 3(b) of the Standard Specifications is void.

PLANS AND SPECIFICATION

Section 111 of the Standard Specifications is void and replaced by the following:

- 1) The County will place review copies of the Plans and Specifications on file at the office of the Lancaster County Engineer. The Specifications are also available via the e-bid process by downloading the documents from the City of Lincoln/Lancaster County website.
- 2) Upon award of the Contract, the Contractor may request up to three (3) additional sets of Plans and Specifications at no charge.
- 3) Additional Specifications may be purchased by payment of the current reproduction fee.

TRAFFIC CONTROL

Section 104.05 (3.) of the Standard Specification is void.

The Contractor will barricade and sign the project and detour in accordance with the Plans included in these Special Provisions. The Contractor will maintain both the barricades and construction signs throughout the duration of the project.

PROVISIONS FOR TRAFFIC

In those instances where permitted, the Contractor may close the road to all traffic except local traffic. The Contractor will at all times, to the extent practicable, provide facilities for continuous uninterrupted egress and ingress to and from the nearest intersecting public roads or streets for local traffic which has its origin or destination within the limits of the project.

In the instances where road closure is not permitted (lane closure only) the Contractor will conduct all construction operations such that the warning signs and traffic control devices may be removed or laid down allowing the traffic lane to be safely re-opened to traffic each evening. (See Special Provision entitled "Method of Completion").

Temporary approaches and/or crossings shall be provided and maintained in a safe condition by the Contractor. This work will not be paid for directly, it will be considered subsidiary to items of work for which direct payment is made.

DESCRIPTION OF CRACK SEALING BITUMINOUS SURFACING

The following roads are to be crack sealed as listed:

- 1) Saltillo Road – Highway 77 to South 15th Street, and South 27th Street to South 96th Street
- 2) South 27th Street – Saltillo Road north 0.5 mile
- 3) South 56th Street – Saltillo Road to Yankee Hill Road
- 4) South 68th Street – Saltillo Road to Roca Road
- 5) South 68th Street – Stagecoach Road to Princeton Road
- 6) West Denton Road – SW 60th Street to Folsom Street
- 7) SW 98th Street & SW 100th Street – Highway 33 to Denton Road

ACCOMMODATION OF TRAFFIC FOR BITUMINOUS PAVEMENT CRACK SEALING

The Contractor shall limit the crack sealing work performed on this project to one traffic lane per worksite, with the other lane used for the accommodation of traffic through the worksite.

The traffic movements through the worksite(s) will be controlled in accordance with the *Traffic Control Plan* included in the specifications. The Contractor may restrict the traveling public to one-way traffic at the worksite(s). During all of the time traffic is restricted to one lane, at least one flagger shall be provided by the Contractor at each end of the worksite to direct the orderly movement of the traffic.

The Contractor will also provide traffic cones (minimum 18" tall) at centerline of road spaced approximately 50' apart to protect the work zone. No direct payment will be made for furnishing and installing traffic cones, but shall be subsidiary to items for which direct payment is made.

The maximum length of a worksite shall be one mile. In the event that the Contractor elects to utilize more than one worksite simultaneously, the worksites must be in the same traffic lanes and a minimum of one mile separation between worksites shall prevail.

Any changes or exceptions to the control of traffic outlined in these Special Provisions will need to be approved by the Engineer.

SANITARY PROVISIONS

The Contractor shall provide restrooms facilities for the project as specified in *Section 107.06 of the Standard Specifications*.

COMPLETION OF PROJECT

All work is to be completed by November 2, 2018. Liquidated damages for calendar days used after November 2, 2018 will be assessed in accordance with *Section 108.08 of the Standard Specifications*.

CONSTRUCTION SITE CONTROL

To the extent permitted by law, the County relinquishes control of the construction site to the Contractor and its Subcontractors during the period of construction. The construction, placement of barricades, and posting of warning signs in the area of construction will be the responsibility of the Contractor. This shall include the placement of construction equipment and any obstacles which are created as a result of the construction project. The placement of barricades and warning signs shall be in compliance with the current edition of the *Manual on Uniform Traffic Control Devices and the 2007 Edition of the Standard Specifications of Highway Construction of the State of Nebraska*. The placement of such barricades and signs shall be reviewed by the County Engineer's Office prior to commencement of the project to ensure compliance. To the extent permitted by law, the Contractor expressly accepts control of the construction site, such control shall include, but not be limited to, barricades, signs, road crossing, construction equipment and any obstacles created during construction of the project.

SEALANTS

The rubber modified asphalt joint sealant acceptable for use on this project shall be on the Nebraska Department of Transportation approved product list. The rout dimension shall be ½" wide by ¾" deep. Toilet paper is an acceptable blotting agent for freshly filled cracks.

BARRICADES

All barricades and sign supports furnished under this specification will be compliant with the National Cooperative Highway Research Program (NCHRP) Report #350 (Test Level -3)

The barricades will be provided by the Contractor in accordance with the Barricade Plan for each site as indicated in the plans for the project or as directed by the Project Engineer. All barricades furnished shall be Type II or Type III and will be equipped with Type "A" flashing lights. All barricades required by the Barricade Plan or the Detour Plan will be properly erected prior to any work beginning at the construction site. Maintenance of and payment for barricades will be in accordance with *Subsection 937.09* of the *Standard Specifications*.

Once work on the project site(s) has been completed, the Project Engineer will direct the Contractor to pick up and remove the barricades, construction signs and the appurtenances thereto. The Contractor or his subcontractor will perform the removal work within five (5) calendar days. If in the event the removal is not done within the time period specified, Lancaster County forces will remove and store, at the nearest maintenance facility, the items described above. A fee of \$50.00/hour for each hour will be charged for the removal expense incurred by County forces. The expense will be reduced from any payments due the Contractor.

CONSTRUCTION SIGNS

All construction signs furnished under this specification will be compliant with the National Cooperative Highway Research Program (NCHRP) Report #350 (Test Level - 3).

The construction signs will be provided by the Contractor in accordance with the "Barricade Plan," the "Detour Plan," or as directed by the Project Engineer. Each construction site will be barricaded; however, not all sites will have a designated detour route or a detour plan.

The work will include furnishing each sign regardless of size or message. All signs furnished shall be reflectorized with a material that has a smooth, sealed outer surface which will display approximately the same size, shape, and color both day and night.

All signs furnished for use in work areas or on detour routes designated for the project shall meet all applicable standards and specifications prescribed in Parts II and V and Part VI of the latest edition of the *Manual On Uniform Traffic Control Devices* (M.U.T.C.D.). See the "Detour Plans" attached to *Special Provisions*.

It is the intent of this specification that the construction signs specified herein be fastened to the Type III barricades or 4" x 4" wooden posts of adequate length as shown on the plans or called for in the *Special Provisions*. If in the opinion of the Project Engineer this method of erection proves unsatisfactory, the Contractor will be required to provide the necessary sign supports and fasteners at no additional cost. All construction signs and non-standard signs required by the barricade plan or the detour plan will be erected prior to any work beginning at the construction site.

Payment for construction signs will be measured by the number of calendar days each sign remains in use on the project regardless of the size, type, mounting method, or message appearing on the sign. The unit for this work shall be known as a "Sign Day".

This price shall be full and complete compensation for furnishing all labor, material, equipment, and other incidentals necessary to provide, erect, maintain, repair, and remove construction signs.

The County will supply non-standard signs to be attached to the Type II or Type III barricades by the Contractor to aid in the control of traffic during the work. The Contractor shall remove and return the signs to the County upon completion of the work. The installation, maintenance, and removal of non-standard signs will not be paid for directly but will be subsidiary to the items for which direct payment is made.

TYPICAL SECTION

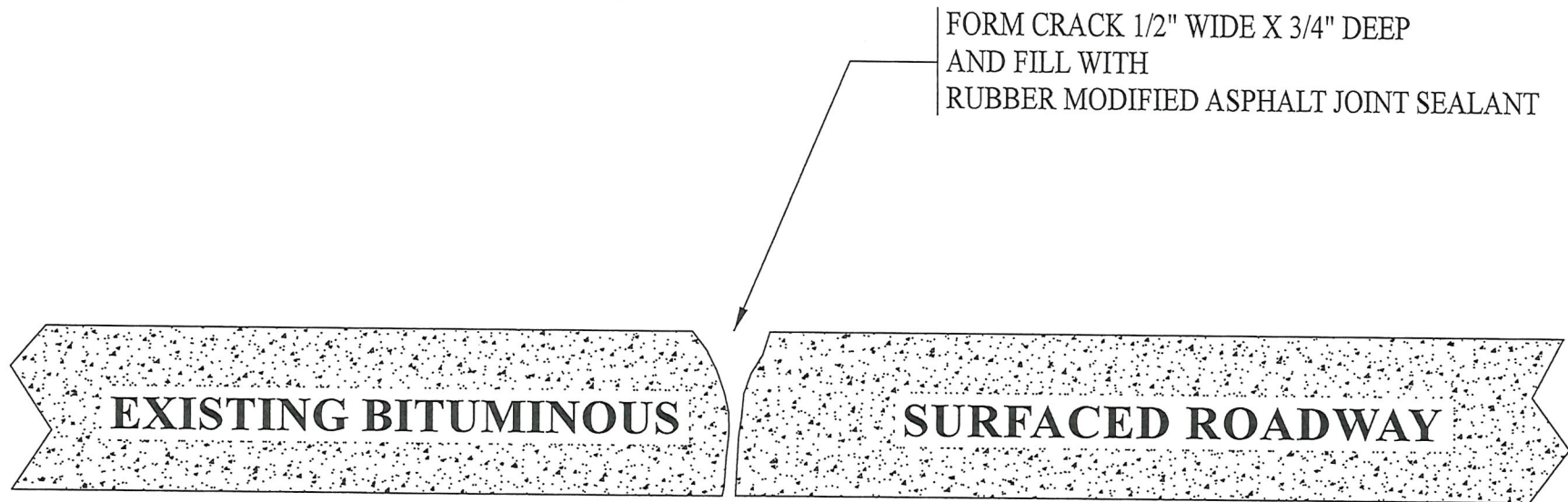

**DETAIL OF TYPICAL TRANSVERSE AND LONGITUDINAL CRACK
SEALING ON BITUMINOUS SURFACED ROADWAY**

TRAFFIC CONTROL PLAN

PROJECT NO. 18-22
CRACK SEALING BITUMINOUS PAVEMENT

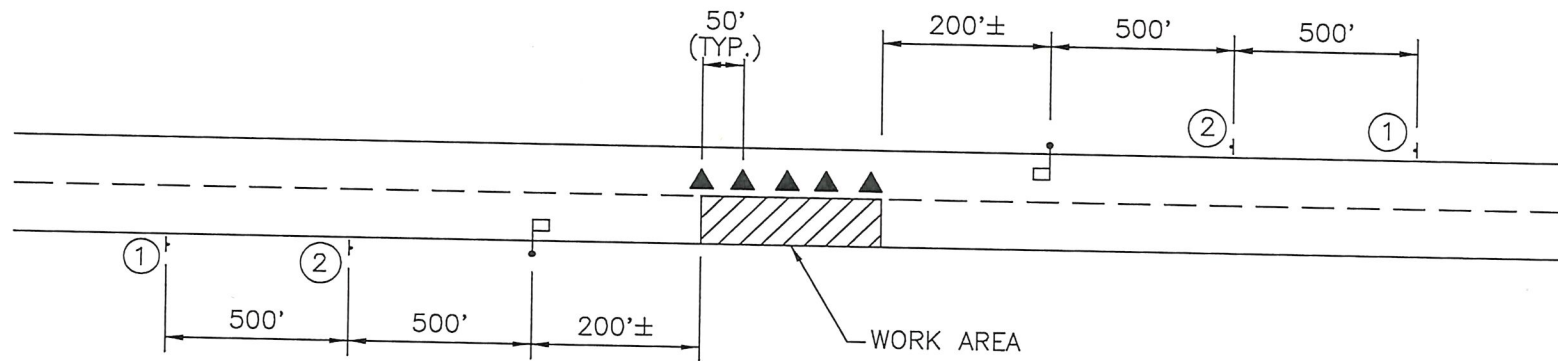

LEGEND

- ① ROAD WORK AHEAD SIGN (W21-4A)
- ② ADVANCE FLAGGER SYMBOL SIGN (W20-7A)
- 🚧 FLAGGER
- ▲ FLUORESCENT TRAFFIC CONES (MINIMUM 18" TALL)

DUPLICATE ORIGINAL

Bond #10161824

PERFORMANCE AND LABOR AND MATERIAL PAYMENT BOND

KNOW ALL MEN BY THESE PRESENTS, that we, Scodeller Construction, Inc. as principal, hereinafter referred to as "Contractor," and The Guarantee Company of North America USA, a corporate surety company authorized to transact business in the State of Nebraska as surety, hereinafter referred to as "Surety," are held and firmly bound unto the County of Lancaster, Nebraska, hereinafter referred to as "County," in the penal sum of One Hundred Ten Thousand Seven Hundred Dollars and 00/100 (\$110,700.00) lawful money of the United States for the payment of which sum, well and truly to be made, we bind ourselves and our heirs, executors, administrators, legal representatives, successors, and assigns jointly and severally, firmly by these presents.

THE CONDITION OF THIS OBLIGATION is such that whereas, the Contractor has entered into a certain contract with the County, dated _____, _____, which contract hereby defined to include all contract documents (instructions to bidders, the accepted bid proposal, special and general conditions, specifications, and drawings) is by reference hereby made a part hereof and is hereinafter referred to as "Contract" for Project No. 18-22 – Crack Sealing Bituminous Surfacing, Lancaster County, Nebraska.

NOW, THEREFORE, IF THE Contractor (1) shall in all particulars well, duly, and faithfully observe, perform, and abide by each and every covenant, condition, and part of the Contract according to the true intent and meaning in each case AND save harmless and defend the County from all suits, judgments, damages, costs, charges, and expenses which may accrue from failure to do so AND make good any and all guarantees which the Contract may require of the Contractor or of the subcontractors; and (2) shall duly pay for all labor, materials, equipment, tools, repairs on machinery, provisions, utilities, fuels, lubricants, and all other supplies or materials actually used or rented by the Contractor or by the subcontractors in performance of the Contract including all insurance premiums on insurance required by the Contract together with interest as provided by law - THEN this obligation shall be and become null and void; otherwise, it shall remain in full force and effect.

PROVIDED FURTHER, that the Surety for value received hereby stipulates and agrees that no change, extension of time, alteration, or addition to the terms of the Contract or to the work to be performed thereunder shall in any wise affect the Surety's obligation on this bond; and the Surety hereby waives notice of any change, extension of time, alteration, or addition to the terms of the Contract or to the work to be performed thereunder.

IN WITNESS WHEREOF, this bond is executed this 6th day of July, 2018



Witness
51722 Grand River Ave Wixom MI 48393
Address

Scodeller Construction, Inc.

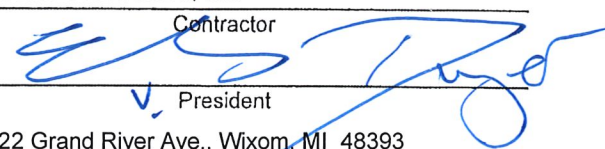
Contractor

President
51722 Grand River Ave., Wixom, MI 48393
Address

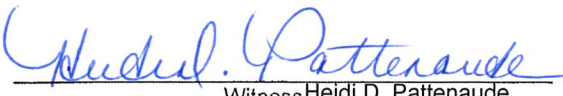

Witness Heidi D. Pattenau
25800 Northwestern Hwy., Suite #535, Southfield, MI
Address 48075

The Guarantee Company of North America USA

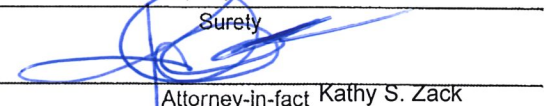
Surety

Attorney-in-fact Kathy S. Zack
One Towne Square, Suite #1470, Southfield, MI 48076
Address

(Accompany this bond with Attorney-in-fact's authority from Surety, certified to include the above date of the bond.)



POWER OF ATTORNEY

NOW ALL BY THESE PRESENTS: That THE GUARANTEE COMPANY OF NORTH AMERICA USA, a corporation organized and existing under the laws of the State of Michigan, having its principal office in Southfield, Michigan, does hereby constitute and appoint

Kathy S. Zack, Michael C. Schatz, Heidi D. Pattenaude, Jennifer A. Jarosz
Cornish, Zack, Hill & Associates, Inc.

its true and lawful attorney(s)-in-fact to execute, seal and deliver for and on its behalf as surety, any and all bonds and undertakings, contracts of indemnity and other writings obligatory in the nature thereof, which are or may be allowed, required or permitted by law, statute, rule, regulation, contract or otherwise.

The execution of such instrument(s) in pursuance of these presents, shall be as binding upon THE GUARANTEE COMPANY OF NORTH AMERICA USA as fully and amply, to all intents and purposes, as if the same had been duly executed and acknowledged by its regularly elected officers at the principal office.

The Power of Attorney is executed and may be certified so, and may be revoked, pursuant to and by authority of Article IX, Section 9.03 of the By-Laws adopted by the Board of Directors of THE GUARANTEE COMPANY OF NORTH AMERICA USA at a meeting held on the 31st day of December, 2003. The President, or any Vice President, acting with any Secretary or Assistant Secretary, shall have power and authority:

- 1. To appoint Attorney(s)-in-fact, and to authorize them to execute on behalf of the Company, and attach the Seal of the Company thereto, bonds and undertakings, contracts of indemnity and other writings obligatory in the nature thereof; and
2. To revoke, at any time, any such Attorney-in-fact and revoke the authority given, except as provided below
3. In connection with obligations in favor of the Florida Department of Transportation only, it is agreed that the power and authority hereby given to the Attorney-in-Fact includes any and all consents for the release of retained percentages and/or final estimates on engineering and construction contracts required by the State of Florida Department of Transportation. It is fully understood that consenting to the State of Florida Department of Transportation making payment of the final estimate to the Contractor and/or its assignee, shall not relieve this surety company of any of its obligations under its bond.
4. In connection with obligations in favor of the Kentucky Department of Highways only, it is agreed that the power and authority hereby given to the Attorney-in-Fact cannot be modified or revoked unless prior written personal notice of such intent has been given to the Commissioner - Department of Highways of the Commonwealth of Kentucky at least thirty (30) days prior to the modification or revocation.

Further, this Power of Attorney is signed and sealed by facsimile pursuant to resolution of the Board of Directors of the Company adopted at a meeting duly called and held on the 6th day of December 2011, of which the following is a true excerpt:

RESOLVED that the signature of any authorized officer and the seal of the Company may be affixed by facsimile to any Power of Attorney or certification thereof authorizing the execution and delivery of any bond, undertaking, contracts of indemnity and other writings obligatory in the nature thereof, and such signature and seal when so used shall have the same force and effect as though manually affixed.

IN WITNESS WHEREOF, THE GUARANTEE COMPANY OF NORTH AMERICA USA has caused this instrument to be signed and its corporate seal to be affixed by its authorized officer, this 2nd day of October, 2015.



THE GUARANTEE COMPANY OF NORTH AMERICA USA

[Signature of Stephen C. Ruschak]

[Signature of Randall Musselman]

STATE OF MICHIGAN
County of Oakland

Stephen C. Ruschak, President & Chief Operating Officer

Randall Musselman, Secretary

On this 2nd day of October, 2015 before me came the individuals who executed the preceding instrument, to me personally known, and being by me duly sworn, said that each is the herein described and authorized officer of The Guarantee Company of North America USA; that the seal affixed to said instrument is the Corporate Seal of said Company; that the Corporate Seal and each signature were duly affixed by order of the Board of Directors of said Company.



Cynthia A. Takai
Notary Public, State of Michigan
County of Oakland
My Commission Expires February 27, 2024
Acting in Oakland County

IN WITNESS WHEREOF, I have hereunto set my hand at The Guarantee Company of North America USA offices the day and year above written.

[Signature of Cynthia A. Takai]

I, Randall Musselman, Secretary of THE GUARANTEE COMPANY OF NORTH AMERICA USA, do hereby certify that the above and foregoing is a true and correct copy of a Power of Attorney executed by THE GUARANTEE COMPANY OF NORTH AMERICA USA, which is still in full force and effect.



IN WITNESS WHEREOF, I have thereunto set my hand and attached the seal of said Company this 6th day of July, 2018

[Signature of Randall Musselman]

Randall Musselman, Secretary



THE GUARANTEE COMPANY OF NORTH AMERICA USA
 One Towne Square, Suite 1470
 Southfield, Michigan 48076
 Phone: 248-281-0281 Fax: 248-750-0431
www.gcna.com

Bid Bond

CONTRACTOR:
 (Name, legal status and address)

Scodeller Construction, Inc.
4410 S. 40th, Suite C
St. Joseph, MO 64503

SURETY:
 (Name, legal status and principal place of business)

The Guarantee Company of North America USA
One Towne Square, Suite 1470
Southfield, Michigan 48076

OWNER:
 (Name, legal status and address)

County Treasurer of Lancaster County, Nebraska
Purchasing Division, 440 S. 8th St., Suite 200
Lincoln, NE 68508

This document has important legal consequences. Consultation with an attorney is encouraged with respect to its completion or modification.

Any singular reference to Contractor, Surety, Owner or other party shall be considered plural where applicable.

BOND AMOUNT: Five Percent (5%) of attached bid

PROJECT:
 (Name, location or address and Project number, if any)

Crack Sealing Bituminous Surfacing
Project No. 18-22 - Lancaster County Bid No. 18-141

The Contractor and Surety are bound to the Owner in the amount set forth above, for the payment of which the Contractor and Surety bind themselves, their heirs, executors, administrators, successors and assigns, jointly and severally, as provided herein. The conditions of this Bond are such that if the Owner accepts the bid of the Contractor within the time specified in the bid documents, or within such time period as may be agreed to by the Owner and Contractor, and the Contractor either (1) enters into a contract with the Owner in accordance with the terms of such bid, and gives such bond or bonds as may be specified in the bidding or Contract Documents, with a surety admitted in the jurisdiction of the Project and otherwise acceptable to the Owner, for the faithful performance of such Contract and for the prompt payment of labor and material furnished in the prosecution thereof, or (2) pays to the Owner the difference, not to exceed the amount of this Bond, between the amount specified in said bid and such larger amount for which the Owner may in good faith contract with another party to perform the work covered by said bid, then this obligation shall be null and void, otherwise to remain in full force and effect. The Surety hereby waives any notice of an agreement between the Owner and Contractor to extend the time in which the Owner may accept the bid. Waiver of notice by the Surety shall not apply to any extension exceeding sixty (60) days in the aggregate beyond the time for acceptance of bids specified in the bid documents, and the Owner and Contractor shall obtain the Surety's consent for an extension beyond sixty (60) days.

If this Bond is issued in connection with a subcontractor's bid to a Contractor, the term Contractor in this Bond shall be deemed to be Subcontractor and the term Owner shall be deemed to be Contractor.

When this Bond has been furnished to comply with a statutory or other legal requirement in the location of the Project, any provision in this Bond conflicting with said statutory or legal requirement shall be deemed deleted herefrom and provisions conforming to such statutory or other legal requirement shall be deemed incorporated herein. When so furnished, the intent is that this Bond shall be construed as a statutory bond and not as a common law bond.

Signed and sealed this 13th day of June, 2018

[Signature]
 (Witness)

Scodeller Construction, Inc.
[Signature] Principal (Seal)
Division Manager (Title)

[Signature]
 (Witness)

The Guarantee Company of North America USA
 (Surety)
[Signature]
 Kathy S. Zack Attorney-In-Fact (Title), (Seal)



The Guarantee Company of North America USA
Southfield, Michigan

POWER OF ATTORNEY

NOW ALL BY THESE PRESENTS: That THE GUARANTEE COMPANY OF NORTH AMERICA USA, a corporation organized and existing under the laws of the State of Michigan, having its principal office in Southfield, Michigan, does hereby constitute and appoint

Kathy S. Zack, Michael C. Schatz, Heidi D. Pattenau, Jennifer A. Jarosz
Cornish, Zack, Hill & Associates, Inc.

its true and lawful attorney(s)-in-fact to execute, seal and deliver for and on its behalf as surely, any and all bonds and undertakings, contracts of indemnity and other writings obligatory in the nature thereof, which are or may be allowed, required or permitted by law, statute, rule, regulation, contract or otherwise.

The execution of such instrument(s) in pursuance of these presents, shall be as binding upon THE GUARANTEE COMPANY OF NORTH AMERICA USA as fully and amply, to all intents and purposes, as if the same had been duly executed and acknowledged by its regularly elected officers at the principal office.

The Power of Attorney is executed and may be certified so, and may be revoked, pursuant to and by authority of Article IX, Section 9.03 of the By-Laws adopted by the Board of Directors of THE GUARANTEE COMPANY OF NORTH AMERICA USA at a meeting held on the 31st day of December, 2003. The President, or any Vice President, acting with any Secretary or Assistant Secretary, shall have power and authority:

1. To appoint Attorney(s)-in-fact, and to authorize them to execute on behalf of the Company, and attach the Seal of the Company thereto, bonds and undertakings, contracts of indemnity and other writings obligatory in the nature thereof; and
2. To revoke, at any time, any such Attorney-in-fact and revoke the authority given, except as provided below
3. In connection with obligations in favor of the Florida Department of Transportation only, it is agreed that the power and authority hereby given to the Attorney-in-Fact includes any and all consents for the release of retained percentages and/or final estimates on engineering and construction contracts required by the State of Florida Department of Transportation. It is fully understood that consenting to the State of Florida Department of Transportation making payment of the final estimate to the Contractor and/or its assignee, shall not relieve this surety company of any of its obligations under its bond.
4. In connection with obligations in favor of the Kentucky Department of Highways only, it is agreed that the power and authority hereby given to the Attorney-in-Fact cannot be modified or revoked unless prior written personal notice of such intent has been given to the Commissioner - Department of Highways of the Commonwealth of Kentucky at least thirty (30) days prior to the modification or revocation.

Further, this Power of Attorney is signed and sealed by facsimile pursuant to resolution of the Board of Directors of the Company adopted at a meeting duly called and held on the 6th day of December 2011, of which the following is a true excerpt:

RESOLVED that the signature of any authorized officer and the seal of the Company may be affixed by facsimile to any Power of Attorney or certification thereof authorizing the execution and delivery of any bond, undertaking, contracts of indemnity and other writings obligatory in the nature thereof, and such signature and seal when so used shall have the same force and effect as though manually affixed.

IN WITNESS WHEREOF, THE GUARANTEE COMPANY OF NORTH AMERICA USA has caused this instrument to be signed and its corporate seal to be affixed by its authorized officer, this 2nd day of October, 2015.



THE GUARANTEE COMPANY OF NORTH AMERICA USA

STATE OF MICHIGAN
County of Oakland

Stephen C. Ruschak, President & Chief Operating Officer

Randall Musselman, Secretary

On this 2nd day of October, 2015 before me came the individuals who executed the preceding instrument, to me personally known, and being by me duly sworn, said that each is the herein described and authorized officer of The Guarantee Company of North America USA; that the seal affixed to said instrument is the Corporate Seal of said Company; that the Corporate Seal and each signature were duly affixed by order of the Board of Directors of said Company.



Cynthia A. Takai
Notary Public, State of Michigan
County of Oakland
My Commission Expires February 27, 2024
Acting in Oakland County

IN WITNESS WHEREOF, I have hereunto set my hand at The Guarantee Company of North America USA offices the day and year above written.

I, Randall Musselman, Secretary of THE GUARANTEE COMPANY OF NORTH AMERICA USA, do hereby certify that the above and foregoing is a true and correct copy of a Power of Attorney executed by THE GUARANTEE COMPANY OF NORTH AMERICA USA, which is still in full force and effect.



IN WITNESS WHEREOF, I have thereunto set my hand and attached the seal of said Company this 13th day of June, 2018

Randall Musselman, Secretary

DEPARTMENT OF INSURANCE

CERTIFICATE OF AUTHORITY

THE GUARANTEE COMPANY OF NORTH AMERICA USA

DOMICILED IN THE STATE OF MICHIGAN

IS HEREBY AUTHORIZED AND LICENSED TO TRANSACT THE BUSINESS OF INSURANCE IN THE STATE OF NEBRASKA AS DESCRIBED BY THE FOLLOWING SUB-SECTION(S) OF SECTION 44-201, OF THE STATUTES OF NEBRASKA:

- 05 Property Insurance
- 06 Credit Property
- 07 Glass Insurance
- 08 Burglary and Theft Insurance
- 09 Boiler and Machinery Insurance
- 10 Liability Insurance
- 12 Vehicle Insurance
- 13 Fidelity Insurance
- 14 Surety Insurance
- 16 Credit Insurance
- 18 Marine Insurance
- 20 Miscellaneous Insurance

151030

NEBRASKA IDENTIFICATION NUMBER

May 1, 2018

DATE ISSUED

April 30, 2019

DATE EXPIRES



SIGNED AT LINCOLN, NEBRASKA

Bruce R. Range
DIRECTOR OF INSURANCE

CONTRACT AGREEMENT

RE: PURCHASING AGENT APPOINTMENT

The Contractor performing work for the County of Lancaster, Nebraska, will be issued a Purchasing Agent Appointment signed by the Purchasing Agent of the County. It is to be used by the Contractor and his subcontractors when purchasing tangible personal property to be actually incorporated into the contract work including materials incidental but necessary to the performance of the contract, provided that such materials are actually incorporated into the contract work. It does not apply to either (1) the purchase of materials to be used but not incorporated into the contract work including but not limited to form lumber, scaffold, etc.; or (2) the purchase or rental of machinery, equipment, or tools owned or leased by the Contractor or his subcontractors and used in performing the contract work.

Purchase qualifying as aforesaid shall be considered as being made by the County. The County shall be obligated to the vendor for the purchase price; but the Contractor or subcontractor, as the case may be, shall handle all payments therefore on behalf of the County. The vendor shall agree to make demand or claim for payment of the purchase price from the County by submitting an invoice to the Contractor or subcontractor. Title to all materials and supplies so qualifying shall vest in the County directly from the vendor; and regardless of the method of payment, title shall vest in the County as otherwise provided in the contract with the County. The Contractor or subcontractor shall not acquire title to any material incorporated into the project. All invoices shall bear the Contractor's or subcontractor's name as agent for the County.

The Contractor may reproduce copies of this Contract Agreement and of the original of the aforesaid Appointment and Certificate to furnish to his suppliers on each invoice or order. The Contractor shall enter the supplier's (the vendor's) name and address, the date, the invoice or order number, a description of the items, and the amount in the spaces provided and shall sign the certificate on the line provided for the "Purchaser's Agent."

The Contractor shall provide each subcontractor with a copy of this Contract Agreement; and of said Appointment and Certificate, the Contractor shall add the subcontractor's name and address in the places provided therefore. Each subcontractor is hereby given the authority to reproduce copies of the copy of said Appointment and Certificate thus provided him by the Contractor and to furnish the same to his (the subcontractor's) suppliers on each invoice or order, and the subcontractor shall complete and sign the same for his purchases in like manner as above set forth for the Contractor.

Nebraska Resale or Exempt Sale Certificate for Sales Tax Exemption

Name and Mailing Address of Purchaser			Name and Mailing Address of Seller		
Name Lancaster County			Name Scodeller Construction		
Legal Name					
Street or Other Mailing Address 555 S. 10th St.			Street or Other Mailing Address 51722 Grand River		
City Lincoln	State NE	Zip Code 68508	City Wixom	State MI	Zip Code 48393

Check Type of Certificate

- Single Purchase If single purchase is checked, enter the related invoice or purchase order number _____
- Blanket If blanket is checked, this certificate is valid until revoked in writing by the purchaser.

I hereby certify that the purchase, lease, or rental by the above purchaser is exempt from the Nebraska sales tax for the following reason:

- Check One** Purchase for Resale (Complete Section A.) Exempt Purchase (Complete Section B.) Contractor (Complete Section C.)

Section A — Nebraska Resale Certificate

Description of Property or Service Purchased

I hereby certify that the purchase, lease, or rental of _____ from the seller listed above is exempt from the Nebraska sales tax as a purchase for resale, rental, or lease in the normal course of our business. The property or service will be resold either in the form or condition in which it was purchased, or as an ingredient or component part of other property or service to be resold.

I further certify that we are engaged in business as a: Wholesaler Retailer Manufacturer Lessor

Description of Product Sold, Leased, or Rented

of _____

My Nebraska Sales Tax ID Number is 01-_____.

If none, state the reason _____

or Foreign State Sales Tax Number _____ State _____.

Section B — Nebraska Exempt Sale Certificate

The basis for this exemption is exemption category 1 (See the list of Exemption Categories and corresponding numbers on reverse side).

If exemption category 2 or 5 is claimed, enter the following information:

Description of Property or Service Purchased	Intended Use of Property or Service Purchased
_____	_____

If exemption category 3 or 4 is claimed, enter your Nebraska Certificate of Exemption State ID number. 05-_____ Do not enter your Federal Employer ID Number.

If exemption category 6 is claimed, the seller must enter the following information and sign this form below:

Description of Items Sold	Date of Seller's Original Purchase	Was tax paid when purchased by seller?	Was item depreciable?
_____	_____	<input type="checkbox"/> Yes <input type="checkbox"/> No	<input type="checkbox"/> Yes <input type="checkbox"/> No

Section C — For Contractors Only

1. Purchase of building materials or fixtures.

As an Option 1 or Option 3 contractor, I hereby certify that the purchase of building materials and fixtures from the seller listed above are exempt from Nebraska sales tax. My Nebraska Sales or Use Tax ID Number is: _____.

2. Purchases made by an Option 2 contractor under a Purchasing Agent Appointment on behalf of _____ (exempt entity)

As an Option 2 contractor, I hereby certify that the purchase of building materials and fixtures from the seller listed above is exempt from Nebraska sales tax pursuant to the attached Purchasing Agent Appointment and Delegation of Authority for Sales and Use Tax, Form 17.

Any purchaser, agent, or other person who completes this certificate for any purchase which is not for resale, lease, or rental in the regular course of the purchaser's business, or is not otherwise exempted from sales and use taxes is subject to a penalty of \$100 or ten times the tax, whichever amount is larger, for each instance of presentation and misuse. With regard to a blanket certificate, this penalty applies to each purchase made during the period the blanket certificate is in effect. Under penalties of law, I declare that I am authorized to sign this certificate, and to the best of my knowledge and belief, it is correct and complete.

sign here ▶

Authorized Signature

Assistant Purchasing Agent
Title

Date

Authorized Signature Name (please print)

**Do not send this certificate to the Nebraska Department of Revenue. Keep it as part of your records.
Sellers cannot accept incomplete certificates.**

The Department is committed to the fair administration of the Nebraska tax laws. It is unlawful to claim an exemption for purchases of property or services that are subject to tax. Sellers are encouraged to notify the Department of any unlawful use of this form.
revenue.nebraska.gov, 800-742-7474 (NE and IA), 402-471-5729

Instructions

Who May Issue a Resale Certificate. Purchasers are to give the seller a properly completed Form 13, Section A, when making purchases of property or taxable services that will subsequently be resold in the purchaser's normal course of business. The property or services must be resold in the same form or condition as when purchased, or as an ingredient or component part of other property that will be resold.

Who May Issue an Exempt Sale Certificate. Form 13, Section B, may be completed and issued by governmental units or organizations that are exempt from paying Nebraska sales and use taxes. See this list in the [Nebraska Sales Tax Exemptions Chart](#). Most nonprofit organizations are not exempt from paying sales and use tax. Enter the appropriate number from "Exemption Categories" (listed below) that properly reflects the basis for your exemption.

For additional information about proper issuance and use of this certificate, please review [Reg-1-013, Sale for Resale – Resale Certificate](#), and [Reg-1-014, Exempt Sale Certificate](#).

Contractors. Contractors complete Form 13, Section C, part 1 or part 2 based on the option elected on the [Contractor Registration Database](#).

To make tax-exempt purchases of building materials and fixtures, Option 1 or Option 3 contractors must complete Form 13, Section C, Part 1. To make tax-exempt purchases of building materials and fixtures pursuant to a construction project for an exempt governmental unit or an exempt nonprofit organization, Option 2 contractors must complete Form 13, Section C, Part 2. The contractor must also attach a copy of a properly completed [Purchasing Agent Appointment and Delegation of Authority for Sales and Use Tax, Form 17](#), to the Form 13, and both documents must be given to the supplier when purchasing building materials. See the [contractor information guides](#) and [Reg-1-017, Contractors](#), for additional information. Also, see the Important Note under "Exemption Categories" number 3.

When and Where to Issue. The Form 13 must be given to the seller at the time of the purchase to document why sales tax does not apply to the purchase. The Form 13 must be kept with the seller's records for audit purposes.

Sales Tax Number. A purchaser who is engaged in business as a wholesaler or manufacturer is not required to provide an ID number when completing Section A. Out-of-state purchasers may provide their home state sales tax number. Section B does not require a Nebraska ID number when exemption category 1, 2, or 5 is indicated.

Fully Completed Resale or Exempt Sale Certificate. A fully completed resale or exempt sale certificate is proof for the retailer that the sale was for resale or is exempt. For a resale certificate to be fully completed, it must include: (1) identification of the purchaser and seller, type of business engaged in by the purchaser; (2) sales tax permit number; (3) signature of an authorized person; and (4) the date of issuance.

For an exempt sale certificate to be fully completed, it must include: (1) identification of purchaser and seller; (2) a statement that the certificate is for a single purchase or is a blanket certificate covering future sales; (3) a statement of the basis for exemption, including the type of activity engaged in by the purchaser; (4) signature of an authorized person; and (5) the date of issuance.

Penalties. Any purchaser who gives a Form 13 to a seller for any purchase which is other than for resale, lease, or rental in the normal course of the purchaser's business, or is not otherwise exempted from sales and use tax under the Nebraska Revenue Act, is subject to a penalty of \$100 or ten times the tax, whichever is greater, for each instance of presentation and misuse. In addition, any purchaser, or their agent, who fraudulently signs a Form 13 may be found guilty of a Class IV misdemeanor.

Exemption Categories

(Insert appropriate number from the list below in Section B)

1. Governmental units, identified in [Reg-1-072, United States Government and Federal Corporations](#); and [Reg-1-093, Governmental Units](#). Governmental units are not assigned exemption numbers.

Sales to the U.S. government, its agencies, instrumentalities, and corporations wholly owned by the U.S. government are exempt from sales tax. However, sales to institutions chartered or created under federal authority, but which are not directly operated and controlled by the U.S. government for the benefit of the public, generally are taxable.

Purchases by governmental units that are not exempt from Nebraska sales and use taxes include, but are not limited to: governmental units of other states; sanitary and improvement districts; rural water districts; railroad transportation safety districts; and county historical societies.

2. Purchases when the intended use renders it exempt. See [Nebraska Sales Tax Exemption Chart](#).
3. Purchases made by organizations that have been issued a [Nebraska Exempt Organization Certificate of Exemption](#) (Certificate of Exemption). [Reg-1-090, Nonprofit Organizations](#); [Reg-1-091, Religious Organizations](#); and [Reg-1-092, Educational Institutions](#), identify these organizations. These organizations are issued a Certificate of Exemption with a state ID number which must be entered in Section B of Form 13.

Important Note: Nonprofit educational institutions must be accredited regionally or nationally and have their primary campus in Nebraska to be exempt from sales and use tax. Also nonprofit organizations providing any of the types of health care or services that qualify to be exempt must be licensed or certified by the Nebraska Department of Health and Human Services (DHHS) to be exempt from sales and use taxes. There is no sales and use tax exemption prior to these entities being accredited, licensed, or certified. They CANNOT issue either a [Resale or Exempt Sale Certificate, Form 13](#), or a [Purchasing Agent Appointment, Form 17](#), to any retailer or contractor relating to purchases of building materials for construction or repair projects performed prior to being accredited, licensed, or certified. After an entity becomes accredited, licensed, or certified upon completion of the construction project, it may submit a [Form 4](#).

Nonprofit **health care organizations** that hold a Certificate of Exemption are exempt for purchases for use at their facility, or portion of the facility, covered by the license issued under the Nebraska Health Care Facility Licensure Act. Only specific types of health care facilities and activities are exempt. Purchases of items for use at facilities that are not covered under the license, or for any other activities that are not specifically exempt, are taxable. The exemption is not for the entire organization that offers different levels of health care or other activities, but is limited to the specific type of health care that is exempt. Purchases for non-exempt types of health care are taxable.

4. Purchases of motor vehicles, trailers, semitrailers watercraft, and aircraft used predominately as common or contract carrier vehicles; accessories that physically become part of the common or contract carrier vehicle; and repair and replacement parts for these vehicles. The exemption ID number must be entered in Section B of the Form 13. An individual or business that has been issued a common or contract carrier certificate of exemption may only use it to purchase those items described above prior to the expiration date on the certificate. The certificate of exemption expires every 5 years. (See [Nebraska Common or Contract Carrier Information Guide](#)).
5. Purchases of manufacturing machinery and equipment made by a person engaged in the business of manufacturing, including repair and replacement parts or accessories, for use in manufacturing. (See [Reg-1-107, Manufacturing Machinery and Equipment Exemption](#)).
6. Occasional sales of used business or farm machinery or equipment productively used by the seller as a depreciable capital asset for more than one year in his or her business. The seller must have previously paid tax on the item being sold. The seller must complete, sign, and give the Exempt Sale Certificate to the purchaser. (See [Reg-1-022, Occasional Sales](#)). The Form 13 must be kept with the purchaser's records for audit purposes.

Purchasing Agent Appointment and Delegation of Authority for Sales and Use Tax

PURCHASING AGENT APPOINTMENT					
Name and Address of Prime Contractor			Name and Address of Governmental Unit or Exempt Organization		
Name Scodeller Construction			Name Lancaster County		
Street or Other Mailing Address 51722 Grand River			Street or Other Mailing Address 555 S. 10th St.		
City Wixom	State MI	Zip Code 48393	City Lincoln,	State NE	Zip Code 68508
Name and Location of Project			Appointment Information		
Name Crack Sealing Bituminous Surfacing			Effective Date (see Instructions)		
Street or Other Mailing Address			Expiration Date		
City Lancaster County	State NE	Zip Code	Nebraska Exemption Number (Exempt Organizations Only) N/A (Gov't)		
Identify Project Bid No. 18-141 - Project No. 18-22					

The undersigned governmental unit or exempt organization appoints the above-named contractor and the contractor's delegated subcontractors as its agent to purchase and pay for building materials that will be annexed to real estate by them into the tax exempt construction project stated above.

sign here

Authorized Signature of Governmental Unit or Exempt Organization

Title

Date

DELEGATION OF PRIME CONTRACTOR'S AUTHORITY			
Name and Address of Subcontractor		Delegation Information	
Name		Effective Date	
Street or Other Mailing Address		Expiration Date	
City	State	Zip Code	Portion of Project

The undersigned prime contractor hereby delegates authority to act as the purchasing agent of the named governmental unit or exempt organization to the above-named subcontractor.

sign here

Signature of Prime Contractor or Authorized Representative

Title

Date

INSTRUCTIONS

WHO MUST FILE. Any governmental unit or organization that is **exempt** from sales and use tax may appoint as its agent a prime contractor to purchase building materials and/or fixtures that will be annexed to property that belongs to or will belong to the governmental unit or exempt organization pursuant to a construction contract with the governmental unit or exempt organization. The appointment of the prime contractor as its agent is completed by issuing a Purchasing Agent Appointment and Delegation of Authority for Sales and Use Tax, Form 17, to the prime contractor. The Form 17 is required to be given to the contractor **BEFORE** he or she annexes building materials. The governmental unit or exempt organization must identify the project (e.g., east wing, chapel construction, or new school auditorium). Most

nonprofit organizations are NOT exempt from sales tax in Nebraska. In addition, not all governmental units are exempt from Nebraska sales tax. Refer to [Contractor Information](#) on our Web site for additional information on exempt entities. A contractor can confirm the exempt status of a governmental unit or exempt organization by contacting the Nebraska Department of Revenue.

The exemption from the payment of the Nebraska and local option sales and use taxes only applies if the governmental unit or exempt organization directly, or through its contractor, pays for the building materials. **IMPORTANT NOTE:** When an organization that requires licensure in order to be exempt (i.e., nonprofit hospitals), but is not licensed at the time of the construction project, the exempt organization **CANNOT**

issue either a purchasing agent appointment or an exemption certificate. If the exempt organization becomes licensed upon completion of the project, it may apply for a refund of the tax paid or collected by the contractors.

WHENTO FILE. A prime contractor engaging in a construction project with a governmental unit or exempt organization must receive a properly completed and signed Form 17 **BEFORE** any building materials are annexed. If Form 17 is not issued, the contractor must pay the sales and use taxes and the governmental unit or exempt organization may obtain a refund of the taxes paid by the contractor.

WHERE TO FILE. A copy of the completed form should be retained by the governmental unit or exempt organization issuing the Form 17. The original is to be retained by the prime contractor. Copies of this form must be made by the prime contractor for delegation purposes to any subcontractors working on the project identified on this form.

APPOINTMENT INFORMATION. Enter the dates the purchasing agent appointment will become effective and when it will expire. This appointment will not allow any purchases without payment of the tax by the prime contractor or subcontractor before the effective date or after the expiration date. The dates the delegation becomes effective and the expiration dates must be completed. The phrase “upon completion” or similar phrase is not acceptable as an expiration date. The governmental unit or exempt organization may need to issue another Form 17 if the project is not completed within the prior “effective” and “expiration” dates. Exempt organizations must enter their Nebraska Sales and Use Tax Exemption number.

DELEGATION OF PRIME CONTRACTOR’S AUTHORITY. The prime contractor may delegate his or her authority to act as the purchasing agent of the governmental unit or exempt organization to a subcontractor. The prime contractor must complete his or her copy of Form 17 for each subcontractor who is delegated authority to act as a purchasing agent. Reproductions of this delegation must be provided to the subcontractor, who must retain a copy for his or her records, and to the governmental unit or exempt organization.

Enter the dates the delegation of the subcontractor will become effective, when it will expire, and the portion of the project delegated. This delegation will not allow any purchases without payment of the tax by the subcontractor before the delegation date or after the expiration date. Any further delegation from a subcontractor to additional subcontractors must be delegated by providing a copy of the Form 17 that they received from the prime contractor and attaching it to a separate Form 17 with any further delegation to other subcontractors. The purchasing agent appointment is limited to the contractor’s purchase of building materials and/or fixtures for the specific project and is only valid during the appointment dates shown on the Form 17.

EXEMPT SALE CERTIFICATE. A prime contractor who has been appointed to act as a purchasing agent by a governmental unit or exempt organization, and who hires a subcontractor operating as an Option 1 contractor, must provide to that subcontractor a completed copy of Form 17 and a [Nebraska Resale or Exempt Sale Certificate, Form 13](#), with Section C,

Part 2, completed. The subcontractor will retain these forms in his or her records, and will not charge the contractor sales tax on any portion of the invoice involving the annexation of materials to the specific project identified on the Form 17. If these forms are not provided to the subcontractor operating under Option 1, the subcontractor must collect and remit sales tax on the charge for the separately stated building materials portion of the invoice. If the Option 1 subcontractor does not separately state the charge for the building materials from contractor labor, then the entire charge is taxable to the prime contractor.

Contractors operating under Option 2 (maintaining a tax-paid inventory) who have been issued a Form 17 from a governmental unit or an exempt organization, must furnish each vendor a copy of the Form 17 and a Form 13, completing Section C, Part 2, when purchasing building materials that will be annexed to real estate. Forms 13 and 17 must be retained with the vendor’s and contractor’s records for audit purposes. A contractor or subcontractor may reproduce copies of these documents which will be furnished to the vendors for each invoice or order made by them.

Invoices from vendors for the purchase of building materials by the contractor as purchasing agent, or the authorized subcontractor, must clearly identify that such purchase is for the specific Form 17 project.

CREDIT/REFUND OF SALES AND USE TAX. A contractor or subcontractor who has been appointed as a purchasing agent before any materials are annexed, may withdraw sales or use tax-paid materials from inventory that will be annexed to real estate or used to repair property annexed to real estate and receive a credit for the sales or use tax amount previously paid on those materials.

The contractor or subcontractor may take a credit either against his or her current tax liability, or file a [Claim for Overpayment of Sales and Use Tax, Form 7](#), and receive a refund of the sales or use tax paid on those materials.

TOOLS, EQUIPMENT, AND SUPPLIES. The purchase, rental, or lease of tools, supplies, or equipment (i.e., scaffolding, barricades, machinery, etc.) by a contractor for use in the completion of an exempt project CANNOT be purchased tax free, even if the contractor has been issued a Form 17. These items do not become annexed to the real estate.

OPTION 1 CONTRACTOR ONLY. If an Option 1 contractor is the **only** contractor involved in performing work for a governmental unit or exempt organization, a Form 17 is NOT required. The Option 1 contractor must only obtain a Form 13, Section B, from the exempt project owner.

PENALTY. Any person who signs this document with the intent to evade payment of tax is liable for the sales and use tax, interest, and penalty, and may be found guilty of a misdemeanor.

AUTHORIZED SIGNATURE. The purchasing agent appointment must be signed by an officer of the exempt organization or proper government official. The delegation of prime contractor’s authority must be signed by the owner, partner, corporate officer, or other individual authorized to sign by a power of attorney on file with the Nebraska Department of Revenue.

LANCASTER COUNTY

EMPLOYER CLASSIFICATION ACT INSTRUCTIONS

WHEREAS, there is concern over the inappropriate competitive advantages in the public bidding process for local publicly funded construction and delivery service contracts resulting from the misclassification of individuals performing construction labor services as "independent contractors" rather than "employees"; such "independent contractors" are commonly referred to as "1099 workers" due to the IRS form they receive rather than a W-4 which an employee receives;

WHEREAS, this mis-classification of such individuals as "independent contractors" rather than as "employees" eliminates any obligation to pay these individuals legally required minimum or overtime wages, to provide legally required workers' compensation insurance, to make unemployment insurance payments, to pay legally required employment and payroll taxes, and to provide any other health, pension, or benefit such individuals would typically receive if properly classified as employees;

WHEREAS, this mis-classification of individuals performing construction labor services for the contractor as "independent contractors" rather than "employees" is a violation of federal and state law, but is difficult to enforce once public construction or delivery service contracts have been bid, awarded, and entered into;

WHEREAS, the use of public funds to compensate contractors who unlawfully avoid their obligation to pay legally required minimum or overtime wages, to provide legally required workers' compensation insurance, to make unemployment insurance payments, to pay legally required employment and payroll taxes, and to provide any other health, pension, or benefit is not in the public interest; and

WHEREAS, the Employee Classification Act, *Neb. Rev. Stat. §§ 48-2901 to 48-2912* (effective July 15, 2010) provides that any contract entered into between a political subdivision and a contractor shall require that each contractor who performs construction or delivery service pursuant to the contract submit to the political subdivision an affidavit attesting that (1) each individual performing services for such contractor is properly classified under the Employee Classification Act, (2) such contractor has completed a federal I-9 immigration form and has such form on file for each employee performing service, (3) such contractor has complied with *Neb. Rev. Stat. § 4-114* requirements that the contractor register and use a federal immigration employment verification system to determine the work eligibility status of new employees physically performing services in the State of Nebraska, (4) such contractor has no reasonable basis to believe that any individual performing services for such contractor is an undocumented worker, and (5) as of the time of the contract, such contractor is not barred from contracting with the state or any political subdivision pursuant to *§ 48-2912 of the Employee Classification Act*.

NOW, THEREFORE, Lancaster County adopts the following policy as to the bid and award of contracts to contractors for construction and delivery services with Lancaster County;

The Purchasing Agent shall immediately include in the County's notice to bidders for construction contracts that all contractors submitting bids in response to the notice shall affirmatively certify to the Purchasing Agent that all individuals hired to perform construction or delivery labor services for the contractor under the contract shall be properly classified as employees and not as independent contractors if the individual does not meet the requirements of an independent contractor under federal and state law (including the requirements of the State of Nebraska Employee Classification Act), and that the contractor will comply with all legal obligations with respect to these employees (including, but not limited to , minimum and overtime pay, workers' compensation, unemployment compensation, and payment of federal and state payroll taxes). The notice to bidders shall further provide that contractors may use affidavits required pursuant to the Employee Classification Act for this purpose, but that a failure to make the affirmative certification to the Purchasing Agent shall render the bidder ineligible for award of the contract.

The Purchasing Agent shall immediately include the following provisions in contracts for construction or delivery services:

(1) Contractor agrees that each individual performing services for the contractor shall be properly classified as an employee and not as an independent contractor if the individual does not meet the requirements of an independent contractor under the State of Nebraska's Employee Classification Act and that contractor shall comply with all legal obligations with respect to the employee (including, but not limited to, minimum and overtime pay, workers' compensation, unemployment compensation, and payment of federal and state payroll taxes).

(2) Contractor understands and agrees that failure to classify each individual hired to perform services under the contract as an employee rather than as an independent contractor if the individual does not meet the requirements of an independent contractor under the State of Nebraska's Employee Classification Act and/or failure to comply with legal obligations with respect to the employee (including, but not limited to, minimum and overtime pay, workers' compensation, unemployment compensation, and payment of federal and state payroll taxes) shall be considered a breach of the contract and is a ground for rescission of the Contract by the County.

(3) Contractor additionally agrees to include the following provision in each subcontract entered into with a subcontractor as part of the contractor's contract with the County.

(a) Subcontractor agrees that each individual performing services for the subcontractor shall be properly classified as an employee and not as an independent contractor if the individual does not meet the requirements of an independent contractor under the State of Nebraska's Employee Classification Act and that subcontractor shall comply with all legal obligations with respect to the employee (including, but not limited to, minimum and overtime pay, workers' compensation, unemployment compensation, and payment of federal and state payroll taxes).

(b) Subcontractor understands and agrees that subcontractor's failure to properly classify individuals hired to perform services under the subcontract as employees and not as independent contractors if the individual does not meet the requirements of an independent contract under the State of Nebraska's Employee Classification Act and/or failure to comply with legal obligation with respect to the employee (including, but not limited to, minimum and overtime pay, workers' compensation, unemployment compensation, and payment of federal and state payroll taxes) shall be considered a breach of the contract and is a ground for rescission of the subcontract with the contractor.

(4) Contractor agrees that if subcontractor fails to or is suspected of failing to properly classify each individual hired pursuant to the subcontract as an employee and not as an independent contractor if the individual does not meet the requirements of an independent contractor under the State of Nebraska's Employee Classification Act and/or fails to comply with legal obligations with respect to the subcontractor's employees, the contractor shall take appropriate corrective action including, but not limited to, reporting the suspected violation of the State of Nebraska Employee Classification Act to the Nebraska Department of Labor or rescission of the subcontract by the contractor. Written notification of the corrective action shall be submitted to the Lincoln-Lancaster County Purchasing Department. Contractor understands and agrees that contractor's failure to take appropriate corrective action shall be considered a breach of the contractor's contract with the County and is a ground for rescission of the contract by the County.

(5) The County shall notify the Nebraska Department of Labor of any contractor or subcontractor it has determined is in breach of contract due to the terms of this order.

(6) Any contractor or subcontractor who shall have been determined by the Nebraska Department of Labor to have knowingly provided a false affidavit to the County under the State of Nebraska's Employee Classification Act shall be referred to the Purchasing Agent of the County who shall determine whether to declare such contractor or subcontractor an irresponsible bidder who shall be disqualified from receiving any business from the County for a stated period of time.

(7) This policy does not prohibit a contractor or subcontractor from hiring individuals to perform construction labor services as independent contractors, provided that the contractor's or subcontractor's use of such individuals as an independent contractor complies with the criteria found in subdivision 5 of *Neb. Rev. Stat. § 48-604* and is otherwise valid under federal and state law and is not intended to circumvent lawful obligations under federal and state law or county contractual requirements.

EMPLOYEE CLASSIFICATION ACT AFFIDAVIT

For the purpose of complying with THE NEBRASKA EMPLOYEE CLASSIFICATION ACT, Nebraska Revised Statutes 48-2901 to 48-2912,

I, SCODREURE CONSTRUCTION herein below known as the Contractor, state under oath and swear as follows:

1. Each individual performing services for the Contractor is properly classified under the Employee Classification Act.
2. The Contractor has completed a federal I-9 immigration form and has such form on file for each employee performing services.
3. The Contractor has complied with *Neb. Rev. Stat. 4-114*.
4. The Contractor has no reasonable basis to believe that any individual performing services for the Contractor is an undocumented worker.
5. The Contractor is not barred from contracting with state or any political subdivision pursuant to *Neb. Rev. Stat. 48-2912* of this Act.
6. As the Contractor, I understand that pursuant to the Employee Classification Act a violation of the Act by a contractor is grounds for rescission of the contract by Lancaster County. I understand that pursuant to the Act any contractor who knowingly provides a false affidavit may be subject to criminal penalties and upon a second or subsequent violation shall be barred from contracting with Lancaster County for a period of three years after the date of discovery of the falsehood.

I hereby affirm and swear that the statements and information provided on this affidavit are true, complete and accurate. The undersigned person does hereby agree and represent that he or she is legally capable to sign this affidavit and to lawfully bind the Contractor to this affidavit.

PRINT NAME: TEAMONKA STEPLER DWYER
 (First, Middle, Last)

SIGNATURE: [Handwritten Signature]

TITLE: VICER PRES.

State of ~~Nebraska~~ Michigan)
)ss.
 County of Oakland)

This affidavit was signed and sworn to before me, the undersigned Notary Public, on this
6th day of July, 2018.

[Handwritten Signature]
 Notary Public

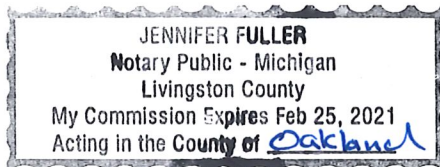

**INSURANCE CLAUSE FOR ALL CITY OF LINCOLN, LANCASTER COUNTY
AND PUBLIC BUILDING COMMISSION CONTRACTS**

Insurance coverage on this Contract will be required for the entities selected below

City of Lincoln Lancaster County Public Building Commission

Vendors must provide coverage & documents related to the items with a check mark in Sections 1 – 1.9.

This includes proof of coverage and waivers as required below.

All Vendors must comply with Sections 2-8.

THE REQUIREMENTS HEREIN APPLY TO CONTRACTS TO BE ISSUED BY THE CITY OF LINCOLN,
LANCASTER COUNTY, AND THE LINCOLN-LANCASTER COUNTY PUBLIC BUILDING COMMISSION.
**FOR PURPOSES OF CERTIFICATES, ENDORSEMENTS AND OTHER PROOF REQUIRED HEREIN, ONLY
INCLUDE THE ENTITY ISSUING THE CONTRACT.**

FAILURE OF THE APPROPRIATE ENTITY (CITY, COUNTY, OR PUBLIC BUILDING COMMISSION) TO
OBJECT TO THE FORM OF THE CERTIFICATE OR ENDORSEMENT OR TO DEMAND SUCH PROOF AS
IS REQUIRED HEREIN SHALL NOT CONSTITUTE A WAIVER OF ANY OF THE INSURANCE
REQUIREMENTS SET FORTH BELOW.

Insurance; Coverage Information

The Contractor shall, prior to beginning work, provide proof of insurance coverage in a form satisfactory to the City/County/PBC, which shall not withhold approval unreasonably. The coverages and minimum levels required by this Contract are set forth below and shall be in effect for all times that work is being done pursuant to this Contract. No work on the Project or pursuant to this Contract shall begin until all insurance obligations herein are met to the satisfaction of the City/County/PBC, which shall not unreasonably withhold approval. Self-insurance shall not be permitted unless consent is given by the City/County/PBC prior to execution of the Contract and may require submission of financial information for analysis. Deductible levels shall be provided in writing from the Contractor's insurer and will be no more than \$25,000 per occurrence or as may be approved by the City or County as appropriate. Said insurance shall be written on an **OCCURRENCE** basis, and shall be **PRIMARY, with any insurance coverage maintained by the City/County/PBC being secondary or excess.**

Certificates

The Contractor shall provide certificates of insurance and such other proof, such as endorsements, as may be acceptable to the City or County (as appropriate) evidencing compliance with these requirements. The Contractor shall provide a Certificate of Insurance demonstrating the coverage required herein and the necessary endorsements or other proof and waivers described herein and below before being permitted to begin the work or project pursuant to this Contract.

1. **Commercial General Liability**

The Contractor shall provide proof of Commercial General Liability Insurance with a minimum limit of not less than \$1,000,000 each occurrence and \$2,000,000 aggregate. These minimum limits can be met by primary and umbrella liability policies. Coverage shall include: Premises-Operations, Products/ Completed Operations, Contractual, Broad Form Property Damage, and Personal Injury. Such coverage shall be endorsed for the general aggregate to be on a **PER PROJECT** basis, and the Contractor shall provide an additional insured endorsement acceptable to the City/County/PBC. The required insurance must include coverage for all projects and operations of Contractor or similar language that meets the approval of the City/County/PBC, which approval shall not be unreasonably withheld.

1.1 **Additional Insured (Requires an Endorsement Form)**

All Contractors shall provide an Additional Insured Endorsement form or other proof showing the City/County/PBC as additional insured for commercial general liability, auto liability and such other coverages as may be required by the City/County/PBC. The form or other proof shall be as is acceptable to the City/County Attorney.

1.2 **Automobile Liability**

The Contractor shall provide proof of Automobile Liability coverage, which shall include: Owned, Hired and Non-Owned. Bodily Injury and Property Damage Combined Single Limit shall be at least \$1,000,000 Per Accident.

1.3 **Garage Keepers / Garage Liability**

The Contractor shall provide garage insurance, if required. Coverage shall include Garage Liability and Garage Keepers on a Direct Primary Basis, including Auto Physical Damage, with limits of not less than \$1,000,000 each accident Bodily Injury and Property Damage combined liability and Actual Cash Value auto physical damage. Coverage symbol(s) 30 and 21 shall be provided, where applicable.

1.4 **Workers' Compensation; Employers' Liability**

The Contractor shall provide proof of workers' compensation insurance of not less than minimum statutory requirements under the laws of the State of Nebraska and any other applicable State. Employers' Liability coverage with limits of not less than \$500,000 each accident or injury shall be included. The Contractor shall provide the City/County/PBC with an endorsement for waiver of subrogation or other proof of such waiver as may be acceptable to the City or County. The Contractor shall also be responsible for ensuring that all subcontractors have workers' compensation insurance for their employees before and during the time any work is done pursuant to this Contract.

1.5 Builder's Risk Insurance

The Contractor shall purchase and maintain builder's risk property insurance for all sites upon which construction is occurring as provided by Contract and all storage sites where equipment, materials, and supplies of any kind purchased pursuant to the Contract are being held or stored unless the Contractor receives notice that the City/County/PBC has obtained a builder's risk policy for itself. Except to the extent recoverable by Contractor from another subcontractor, deductibles shall be the responsibility of the Contractor. This coverage is required whenever the work under contract involves construction or repair of a building structure or bridge.

1.5.1 Waiver of Builder's Risk Insurance Carrier's Subrogation Rights

The Contractor and its subcontractor(s) waive all rights of action and subrogation that the insurance company providing the builder's risk policy may have against each of them and/or the City/County/PBC, Architect, and the officers, agents and employees of any of them, for all claims, damages, injuries and losses, to the extent covered by such property insurance. Such waiver of subrogation shall be effective for such persons even though such persons would otherwise have a duty of indemnification or contribution, contractual or otherwise, and even though such persons did not pay the insurance premium directly or indirectly, and whether or not such persons had an insurable interest in any property damaged. The Contractor or subcontractor shall provide proof of such waiver.

1.6 Pollution Liability

Contractors shall provide proof of pollution liability insurance arising out of all operations of the Contractors and subcontractors, due to discharge, dispersal, release, or escape of contaminants or pollutants into or upon land, the atmosphere or any watercourse or body of water with bodily injury and property damage limits of not less than \$1,000,000 per occurrence and \$2,000,000 annual aggregate for:

- 1) Bodily injury, sickness, disease, mental anguish or shock sustained by any person, including death;
- 2) Property damage including physical injury to or destruction of tangible property including the resulting loss of use thereof, clean-up costs, and the loss of use of tangible property that has not been physically injured or destroyed;
- 3) Defense including loss adjustment costs, charges and expenses incurred in the investigation, adjustment or defense of claims for such compensatory damages;
- 4) Definition of pollution conditions shall include asbestos, lead, and mold so that these risks are covered if caused by Contractor/successful candidate's work or operations.
- 5) Coverage is required on an occurrence form.

1.7 Errors and Omissions; Professional Liability

Errors and Omissions or Professional Liability insurance, as may be required, covering damages arising out of negligent acts, errors, or omissions committed by Contractor in the performance of this Contract, with a liability limit of not less than \$1,000,000 each claim. Contractor shall maintain this policy for a minimum of two (2) years after completion of the work or shall arrange for a two year extended discovery (tail) provision if the policy is not renewed. The intent of this policy is to provide coverage for claims arising out of the performance of professional Services under this contract and caused by any error, omission, breach or negligent act, including infringement of intellectual property (except patent and trade secret) of the Contractor. This coverage is required whenever the Contractor or service provider is required to be certified, licensed or registered by a regulatory entity and/or where the provider's judgment in planning and design could result in economic loss to City/County/PBC.

1.8 Railroad Contractual Liability Insurance

If work is to be performed within 50 feet of any railroad property and affecting any railroad bridge or trestle, tracks, road beds, tunnel, underpass or railroad crossing, the Contractor must provide proof acceptable to the City or County that any exception for such work in the Contractor's commercial general liability policy has been removed or deleted.

1.8.1 Railroad Protective Liability

If work is to be performed within 50 feet of any railroad property and affecting any railroad bridge or trestle, tracks, road beds, tunnel, underpass or crossing or otherwise required by the Special Provisions or applicable requirements of an affected railroad, the Contractor shall provide Railroad Protective Liability Insurance naming the affected railroad/s as insured with minimum limits for bodily injury and property damage of \$2,000,000 per occurrence, \$6,000,000 aggregate, or such other limits as required in the Special Provisions or by the affected railroad. The original of the policy shall be furnished to the railroad and a certified copy of the same furnished to the City/County/PBC Purchasing Department prior to any related construction or entry upon railroad premises by the Contractor or for work related to the Contract.

1.9 Cyber Insurance

The Contractor shall maintain network risk and cyber liability coverage (including coverage for unauthorized access, failure of security, breach of privacy perils, as well as notification costs and regulatory defense) in an amount of not less than \$1,000,000. Such insurance shall be maintained in force at all times during the term of the Contract and for a period of two years thereafter for services completed during the term of the Contract.

2. **Cancellation Notice**

All Contractors shall include an endorsement to provide for at least thirty (30) days' firm written notice in the event of cancellation during the term of the Contract and during the period of any required continuing coverages. The Contractor shall provide, prior to expiration of the policies, certificates and endorsement forms evidencing renewal insurance coverages. The parties agree that the failure of City/County/PBC to object to the form of a certificate and/or additional insured endorsement or endorsement forms provided shall not constitute a waiver of this requirement.

3. **Risk of Loss**

Except to the extent covered by the builder's risk insurance, the Contractor shall have the sole responsibility for the proper storage and protection of, and assumes all risk of loss of, any subcontractor's Work and tools, materials, equipment, supplies, facilities, offices and other property at or off the Project site. The Contractor shall be solely responsible for ensuring each subcontractor shall take every reasonable precaution in the protection of all structures, streets, sidewalks, materials and work of other subcontractors. Contractor shall protect its Work from damage by the elements or by other trades working in the area.

4. **Umbrella or Excess Liability**

The Contractor may use an Umbrella, Excess Liability, or similar coverage to supplement the primary insurance stated above in order to meet or exceed the minimum coverage levels required by this Contract.

5. **Minimum Scope of Insurance**

All Liability Insurance policies shall be written on an "Occurrence" basis only. All insurance coverage are to be placed with insurers authorized to do business in the State of Nebraska and must be placed with an insurer that has an A.M. Best's Rating of no less than A:VII unless specific approval has been granted otherwise.

6. **Indemnification**

To the fullest extent permitted by law the Contractor shall indemnify, defend, and hold harmless the Owner, its elected officials, officers, employees, agents, consultants, and employees of any of them from and against claims, damages, losses and expenses, including but not limited to attorney fees, arising out of or resulting from performance of the Work, provided that such claim, damage, loss or expense is attributable to bodily injury, sickness, disease or death, or to injury to or destruction of tangible or intangible property, including the Work itself, but only to the extent caused by the negligent, wrongful, or intentional acts or omissions of the Contractor, a subcontractor, anyone directly or indirectly employed by them or anyone for whose acts they may be liable, regardless of whether or not such claim, damage, loss or

expense is caused in part by the negligence of a party indemnified hereunder. In the event the claim, damage, loss or expense is caused in part by the negligence of a party indemnified hereunder, the indemnification by the Contractor shall be prorated based on the extent of the liability of the party indemnified hereunder. Such obligation shall not be construed to negate, abridge, or reduce obligations of indemnity which would otherwise exist as to a party or person described in this Section. Nothing herein shall be construed to be a waiver of sovereign immunity by the Owner.

7. **Reservation of Rights**

The City/County/PBC reserves the right to require a higher limit of insurance or additional coverages when the City/County/PBC determines that a higher limit or additional coverage is required to protect the City/County/PBC or the interests of the public. Such changes in limits or coverages shall be eligible for a change order or amendment to the Contract.

8. **Sovereign Immunity**

Nothing contained in this clause or other clauses of this Contract shall be construed to waive the Sovereign Immunity of the City/County/PBC.

9. **Further Contact**

For further information or questions concerning coverage or acceptable forms, Contractors may contact the Purchasing Division or the department that issued the bid or the request for proposal.

For general questions regarding Insurance Requirements, please contact Risk Management for the City or County.



CERTIFICATE OF LIABILITY INSURANCE

DATE (MM/DD/YYYY)
07/27/2018

THIS CERTIFICATE IS ISSUED AS A MATTER OF INFORMATION ONLY AND CONFERS NO RIGHTS UPON THE CERTIFICATE HOLDER. THIS CERTIFICATE DOES NOT AFFIRMATIVELY OR NEGATIVELY AMEND, EXTEND OR ALTER THE COVERAGE AFFORDED BY THE POLICIES BELOW. THIS CERTIFICATE OF INSURANCE DOES NOT CONSTITUTE A CONTRACT BETWEEN THE ISSUING INSURER(S), AUTHORIZED REPRESENTATIVE OR PRODUCER, AND THE CERTIFICATE HOLDER.

IMPORTANT: If the certificate holder is an ADDITIONAL INSURED, the policy(ies) must be endorsed. If SUBROGATION IS WAIVED, subject to the terms and conditions of the policy, certain policies may require an endorsement. A statement on this certificate does not confer rights to the certificate holder in lieu of such endorsement(s).

PRODUCER Dale and Michael Corporation Lyman & Sheets Insurance Agency 2213 E. Grand River Ave. Lansing, MI 48912 David A. Drayton INSURED Scodeller Construction, Inc. 51722 Grand River Wixom, MI 48393	1-517-482-2211 CONTACT NAME: Kathy Satterlee PHONE (A/C, No, Ext): 517-319-5129 FAX (A/C, No): 517-371-4881 E-MAIL ADDRESS: kathys@lymansheets.com PRODUCER CUSTOMER ID #:
INSURER(S) AFFORDING COVERAGE	
INSURER A: OLD REPUBLIC INS CO	NAIC # 24147
INSURER B: CINCINNATI INS CO	10677
INSURER C:	
INSURER D:	
INSURER E:	
INSURER F:	

COVERAGES

CERTIFICATE NUMBER: 53507865

REVISION NUMBER:

THIS IS TO CERTIFY THAT THE POLICIES OF INSURANCE LISTED BELOW HAVE BEEN ISSUED TO THE INSURED NAMED ABOVE FOR THE POLICY PERIOD INDICATED. NOTWITHSTANDING ANY REQUIREMENT, TERM OR CONDITION OF ANY CONTRACT OR OTHER DOCUMENT WITH RESPECT TO WHICH THIS CERTIFICATE MAY BE ISSUED OR MAY PERTAIN, THE INSURANCE AFFORDED BY THE POLICIES DESCRIBED HEREIN IS SUBJECT TO ALL THE TERMS, EXCLUSIONS AND CONDITIONS OF SUCH POLICIES. LIMITS SHOWN MAY HAVE BEEN REDUCED BY PAID CLAIMS.

INSR LTR	TYPE OF INSURANCE	ADDL INSR	SUBR WVD	POLICY NUMBER	POLICY EFF (MM/DD/YYYY)	POLICY EXP (MM/DD/YYYY)	LIMITS
A	GENERAL LIABILITY <input checked="" type="checkbox"/> COMMERCIAL GENERAL LIABILITY <input type="checkbox"/> CLAIMS-MADE <input checked="" type="checkbox"/> OCCUR <input checked="" type="checkbox"/> XCU/Contractual Liab <input checked="" type="checkbox"/> Waiver of Subrogation GEN'L AGGREGATE LIMIT APPLIES PER: <input type="checkbox"/> POLICY <input checked="" type="checkbox"/> PRO-JECT <input type="checkbox"/> LOC	X	X	MWZY 312353	03/01/18	03/01/19	EACH OCCURRENCE \$ 1,000,000 DAMAGE TO RENTED PREMISES (Ea occurrence) \$ 500,000 MED EXP (Any one person) \$ 10,000 PERSONAL & ADV INJURY \$ 1,000,000 GENERAL AGGREGATE \$ 2,000,000 PRODUCTS - COMP/OP AGG \$ 2,000,000 \$
A	AUTOMOBILE LIABILITY <input checked="" type="checkbox"/> ANY AUTO <input type="checkbox"/> ALL OWNED AUTOS <input type="checkbox"/> SCHEDULED AUTOS <input type="checkbox"/> HIRED AUTOS <input type="checkbox"/> NON-OWNED AUTOS	X	X	MWTB 312352	03/01/18	03/01/19	COMBINED SINGLE LIMIT (Ea accident) \$ 1,000,000 BODILY INJURY (Per person) \$ BODILY INJURY (Per accident) \$ PROPERTY DAMAGE (Per accident) \$ \$ \$
B	UMBRELLA LIAB <input checked="" type="checkbox"/> OCCUR EXCESS LIAB <input type="checkbox"/> CLAIMS-MADE DEDUCTIBLE <input checked="" type="checkbox"/> RETENTION \$ none	X	X	EXS 0011266	03/01/18	03/01/19	EACH OCCURRENCE \$ 4,000,000 AGGREGATE \$ 4,000,000 \$ \$
A	WORKERS COMPENSATION AND EMPLOYERS' LIABILITY ANY PROPRIETOR/PARTNER/EXECUTIVE OFFICER/MEMBER EXCLUDED? (Mandatory in NH) If yes, describe under DESCRIPTION OF OPERATIONS below			MWC 312354 00	03/01/18	03/01/19	<input checked="" type="checkbox"/> WC STATU-TORY LIMITS <input type="checkbox"/> OTH-ER E.L. EACH ACCIDENT \$ 1,000,000 E.L. DISEASE - EA EMPLOYEE \$ 1,000,000 E.L. DISEASE - POLICY LIMIT \$ 1,000,000

DESCRIPTION OF OPERATIONS / LOCATIONS / VEHICLES (Attach ACORD 101, Additional Remarks Schedule, if more space is required)

Additional Insured and Waiver of Subrogation status apply when required by written contract.

CERTIFICATE HOLDER**CANCELLATION**

Lancaster County 555 South 10th Street Lincoln, NE 68508 USA	SHOULD ANY OF THE ABOVE DESCRIBED POLICIES BE CANCELLED BEFORE THE EXPIRATION DATE THEREOF, NOTICE WILL BE DELIVERED IN ACCORDANCE WITH THE POLICY PROVISIONS. AUTHORIZED REPRESENTATIVE 
---	--

EamonnDwyer
ACORD 25 (2009/09)
53507865

The ACORD name and logo are registered marks of ACORD

© 1988-2009 ACORD CORPORATION. All rights reserved.

POLICY NUMBER: MWC 312354 00

WAIVER OF OUR RIGHT TO RECOVER FROM OTHERS ENDORSEMENT

We have the right to recover our payments from anyone liable for an injury covered by this policy. We will not enforce our right against the person or organization named in the Schedule. (This agreement applies only to the extent that you perform work under a written contract that requires you to obtain this agreement from us.)

This agreement shall not operate directly or indirectly to benefit anyone not named in the Schedule.

Schedule

**AS REQUIRED BY WRITTEN CONTRACT, TO THE EXTENT ALLOWABLE BY
LAW.**

DATE OF ISSUE: 03/01/18

OLD REPUBLIC INSURANCE COMPANY

WORKERS' COMPENSATION AND EMPLOYERS' LIABILITY INSURANCE POLICY

EARLIER NOTICE OF CANCELATION OR NONRENEWAL PROVIDED BY US

SCHEDULE

<u>Number of Days' Notice of Cancellation Non- payment of Premium</u>	<u>Number of Days' Notice of Cancellation Reasons Other Than Non-payment of Premium or Nonrenewal</u>	<u>State(s) Applicable</u>
10	60	SEE ITEM 3 . A .
<u>Number of Days' Notice of Nonrenewal</u>		<u>State(s) Applicable</u>

- A. For any statutorily permitted reason for cancellation, the number of days required for notice of cancellation, as provided in the Cancellation Condition or as amended by an applicable state cancellation endorsement, is increased to the number of days shown in the Schedule.
- B. For any statutorily permitted nonrenewal, the number of days required for notice of nonrenewal as amended by an applicable state endorsement is increased to the number of days shown in the Schedule.

IL 10 (12/06) OLD REPUBLIC INSURANCE COMPANY

THIS ENDORSEMENT CHANGES THE POLICY. PLEASE READ IT CAREFULLY.

ADDITIONAL INSURED/DESIGNATED INSURED AMENDMENT - PRIMARY AND NON-CONTRIBUTORY

This endorsement modifies insurance provided under the following:

BUSINESS AUTO COVERAGE FORM

SCHEDULE

Designated Person(s) or Organization(s):

All persons or organizations where required by written contract.

WHO IS AN INSURED (SECTION II) is amended to include the person(s) or organization(s) shown in the above Schedule, but only with respect to "accidents" arising out of work being performed for such person(s) or organization(s).

As respects any person(s) or organization(s) shown in the above Schedule with whom you have agreed in a written contract to provide primary insurance on a non-contributory basis, this insurance will be primary to and non-contributing with any other insurance available to such person(s) or organizations(s).

THIS ENDORSEMENT CHANGES THE POLICY. PLEASE READ IT CAREFULLY.

DESIGNATED INSURED FOR COVERED AUTOS LIABILITY COVERAGE

This endorsement modifies insurance provided under the following:

AUTO DEALERS COVERAGE FORM
BUSINESS AUTO COVERAGE FORM
MOTOR CARRIER COVERAGE FORM

With respect to coverage provided by this endorsement, the provisions of the Coverage Form apply unless modified by this endorsement.

This endorsement identifies person(s) or organization(s) who are "insureds" for Covered Autos Liability Coverage under the Who Is An Insured provision of the Coverage Form. This endorsement does not alter coverage provided in the Coverage Form.

This endorsement changes the policy effective on the inception date of the policy unless another date is indicated below.

Named Insured: Scodeller Construction Inc.
Endorsement Effective Date: 03/01/18

SCHEDULE

Name Of Person(s) Or Organization(s): As required by contract or agreement
Information required to complete this Schedule, if not shown above, will be shown in the Declarations.

Each person or organization shown in the Schedule is an "insured" for Covered Autos Liability Coverage, but only to the extent that person or organization qualifies as an "insured" under the Who Is An Insured provision contained in Paragraph **A.1.** of Section **II** – Covered Autos Liability Coverage in the Business Auto and Motor Carrier Coverage Forms and Paragraph **D.2.** of Section **I** – Covered Autos Coverages of the Auto Dealers Coverage Form.

IL 10 (12/06) OLD REPUBLIC INSURANCE COMPANY

THIS ENDORSEMENT CHANGES THE POLICY. PLEASE READ IT CAREFULLY.

EARLIER NOTICE OF CANCELLATION PROVIDED BY US

This endorsement modifies insurance provided under the following:

AUTO DEALERS COVERAGE FORM
BUSINESS AUTO COVERAGE FORM
MOTOR CARRIER COVERAGE FORM

SCHEDULE

Number of Days' Notice 10 (For non-payment of premium)

Number of Days' Notice 60 (For any other reason, other than
nonpayment of premium)

(If no entry appears above, information required to complete this endorsement will be shown in the Declarations as applicable to this endorsement.)

The number of days required for notice of Cancellation, as provided in the Cancellation policy Condition or as amended by an applicable state endorsement, is increased to the number of days shown in the Schedule.

THIS ENDORSEMENT CHANGES THE POLICY. PLEASE READ IT CAREFULLY.

**ADDITIONAL INSURED – OWNERS, LESSEES OR
CONTRACTORS – SCHEDULED PERSON OR
ORGANIZATION**

This endorsement modifies insurance provided under the following:

COMMERCIAL GENERAL LIABILITY COVERAGE PART

SCHEDULE

Name Of Additional Insured Person(s) Or Organization(s)	Location(s) Of Covered Operations
All persons or organizations when required by written contract or agreement	All Locations
Information required to complete this Schedule, if not shown above, will be shown in the Declarations.	

A. Section II – Who Is An Insured is amended to include as an additional insured the person(s) or organization(s) shown in the Schedule, but only with respect to liability for "bodily injury", "property damage" or "personal and advertising injury" caused, in whole or in part, by:

1. Your acts or omissions; or
2. The acts or omissions of those acting on your behalf;

in the performance of your ongoing operations for the additional insured(s) at the location(s) designated above.

However:

1. The insurance afforded to such additional insured only applies to the extent permitted by law; and
2. If coverage provided to the additional insured is required by a contract or agreement, the insurance afforded to such additional insured will not be broader than that which you are required by the contract or agreement to provide for such additional insured.

B. With respect to the insurance afforded to these additional insureds, the following additional exclusions apply:

This insurance does not apply to "bodily injury" or "property damage" occurring after:

1. All work, including materials, parts or equipment furnished in connection with such work, on the project (other than service, maintenance or repairs) to be performed by or on behalf of the additional insured(s) at the location of the covered operations has been completed; or
2. That portion of "your work" out of which the injury or damage arises has been put to its intended use by any person or organization other than another contractor or subcontractor engaged in performing operations for a principal as a part of the same project.

THIS ENDORSEMENT CHANGES THE POLICY. PLEASE READ IT CAREFULLY.

ADDITIONAL INSURED – OWNERS, LESSEES OR CONTRACTORS – COMPLETED OPERATIONS

This endorsement modifies insurance provided under the following:

COMMERCIAL GENERAL LIABILITY COVERAGE PART
PRODUCTS/COMPLETED OPERATIONS LIABILITY COVERAGE PART

SCHEDULE

Name Of Additional Insured Person(s) Or Organization(s)	Location And Description Of Completed Operations
All persons or organizations when required by written contract or agreement	All completed operations
Information required to complete this Schedule, if not shown above, will be shown in the Declarations.	

A. Section II – Who Is An Insured is amended to include as an additional insured the person(s) or organization(s) shown in the Schedule, but only with respect to liability for "bodily injury" or "property damage" caused, in whole or in part, by "your work" at the location designated and described in the Schedule of this endorsement performed for that additional insured and included in the "products-completed operations hazard".

However:

1. The insurance afforded to such additional insured only applies to the extent permitted by law; and
2. If coverage provided to the additional insured is required by a contract or agreement, the insurance afforded to such additional insured will not be broader than that which you are required by the contract or agreement to provide for such additional insured.

B. With respect to the insurance afforded to these additional insureds, the following is added to **Section III – Limits Of Insurance:**

If coverage provided to the additional insured is required by a contract or agreement, the most we will pay on behalf of the additional insured is the amount of insurance:

1. Required by the contract or agreement; or
2. Available under the applicable Limits of Insurance shown in the Declarations;

whichever is less.

This endorsement shall not increase the applicable Limits of Insurance shown in the Declarations.

C. With respect to the insurance afforded to these additional insureds, the following is added to **Section III – Limits Of Insurance:**

If coverage provided to the additional insured is required by a contract or agreement, the most we will pay on behalf of the additional insured is the amount of insurance:

1. Required by the contract or agreement; or

2. Available under the applicable Limits of Insurance shown in the Declarations;

whichever is less.

This endorsement shall not increase the applicable Limits of Insurance shown in the Declarations.

WAIVER OF TRANSFER OF RIGHTS OF RECOVERY AGAINST OTHERS TO US

This endorsement modifies insurance provided under the following:

COMMERCIAL GENERAL LIABILITY COVERAGE PART
PRODUCTS/COMPLETED OPERATIONS LIABILITY COVERAGE PART

SCHEDULE

Name Of Person Or Organization: When required by written contract
--

Information required to complete this Schedule, if not shown above, will be shown in the Declarations.
--

The following is added to Paragraph 8. **Transfer Of Rights Of Recovery Against Others To Us** of Section IV – Conditions:

We waive any right of recovery we may have against the person or organization shown in the Schedule above because of payments we make for injury or damage arising out of your ongoing operations or "your work" done under a contract with that person or organization and included in the "products-completed operations hazard". This waiver applies only to the person or organization shown in the Schedule above.

THIS ENDORSEMENT CHANGES THE POLICY. PLEASE READ IT CAREFULLY.

PRIMARY AND NONCONTRIBUTORY – OTHER INSURANCE CONDITION

This endorsement modifies insurance provided under the following:

COMMERCIAL GENERAL LIABILITY COVERAGE PART
PRODUCTS/COMPLETED OPERATIONS LIABILITY COVERAGE PART

The following is added to the **Other Insurance Condition** and supersedes any provision to the contrary:

Primary And Noncontributory Insurance

This insurance is primary to and will not seek contribution from any other insurance available to an additional insured under your policy provided that:

- (1) The additional insured is a Named Insured under such other insurance; and

- (2) You have agreed in writing in a contract or agreement that this insurance would be primary and would not seek contribution from any other insurance available to the additional insured.

THIS ENDORSEMENT CHANGES THE POLICY. PLEASE READ IT CAREFULLY.

EARLIER NOTICE OF CANCELLATION PROVIDED BY US

This endorsement modifies insurance provided under the following:

COMMERCIAL GENERAL LIABILITY COVERAGE PART
LIQUOR LIABILITY COVERAGE PART
POLLUTION LIABILITY COVERAGE PART
PRODUCTS/COMPLETED OPERATIONS LIABILITY COVERAGE PART

SCHEDULE

Number of Days' Notice 60

(If no entry appears above, information required to complete this Schedule will be shown in the Declarations as applicable to this endorsement.)

For any statutorily permitted reason other than nonpayment of premium, the number of days required for notice of cancellation, as provided in paragraph 2. of either the CANCELLATION Common Policy Condition or as amended by an applicable state cancellation endorsement, is increased to the number of days shown in the Schedule above.