

CONTRACT DOCUMENTS

**CITY OF LINCOLN/LANCASTER COUNTY
NEBRASKA**

**Annual Supply
Aluminum Sign Blanks
Bid No. 17-240**

**Vulcan Signs (Vulcan Inc.)
PO Box 1850
Foley, AL 36536-1850
(251) 943-1541**

**CITY OF LINCOLN/LANCASTER COUNTY, NEBRASKA
CONTRACT TERMS**

THIS CONTRACT, made and entered into by and between **Vulcan Signs (Vulcan Inc.), PO Box 1850, Foley, AL 36536-1850**, hereinafter called "Contractor", and the City of Lincoln, Nebraska, a municipal corporation, and the County of Lancaster, Nebraska, a political subdivision of the State of Nebraska, hereinafter called the "Owners".

WHEREAS, the Owner has caused to be prepared, in accordance with law, Specifications, Plans, and other Contract Documents for the Work herein described, and has approved and adopted said documents and has caused to be published an advertisement for and in connection with said Work, to-wit:

Aluminum Sign Blanks, Bid No. 17-240

and,

WHEREAS, the Contractor, in response to such advertisement, has submitted to the Owners, in the manner and at the time specified, a sealed Proposal/Supplier Response in accordance with the terms of said advertisement; and,

WHEREAS, the Owners, in the manner prescribed by law has publicly opened, read aloud, examined, and canvassed the Proposals/Supplier Responses submitted in response to such advertisement, and as a result of such canvass has determined and declared the Contractor to be the lowest responsible bidder for the said Work for the sum or sums named in the Contractor's Proposal/Supplier Responses, a copy thereof being attached to and made a part of this Contract;

NOW, THEREFORE, in consideration of the sums to be paid to the Contractor and the mutual covenants herein contained, the Contractor and the Owners have agreed and hereby agree as follows:

1. The Contractor agrees to (a) furnish all tools, equipment, supplies, superintendence, transportation, and other accessories, services, and facilities; (b) furnish all materials, supplies, and equipment specified to be incorporated into and form a permanent part of the complete work; (c) provide and perform all necessary labor in a substantial and workmanlike manner and in accordance with the provisions of the Contract Documents; and (d) execute and complete all Work included in and covered by the Owners' award of this Contract to the Contractor, such award being based on the acceptance by the Owner of the Contractor's Proposal, or part thereof, as follows:

Agreement to full proposal with the exception of lines 263 and 264 of Contractors proposal

2. The Owners agree to pay to the Contractor for the performance of the Work embraced in this Contract, the Contractor agrees to accept as full compensation therefore, the following sums and prices for all Work covered by and included in the Contract award and designated above, payment thereof to be made in the manner provided by the Owners:

The Owners will pay for products/service, according to the Line Item pricing as listed in Contractors Proposal/Supplier Response, a copy thereof being attached to and made a part of this Contract. The Owners shall order on an as- needed basis for the duration of

the contract. The cost of products or services for County agencies shall not exceed \$8,000.00 during the contract term without approval by the Board of Commissioners. The cost of products or services for City Departments shall not exceed \$26,000.00 during the contract term without approval.

3. Equal Employment Opportunity. In connection with the carrying out of this project, the contractor shall not discriminate against any employee or applicant for employment because of race, color, religion, sex, national origin, ancestry, disability, age or marital status. The Contractor will take affirmative action to ensure that applicants are employed, and that employees are treated during employment, without regard to their race, color, religion, sex, national origin, ancestry, disability, age or marital status. Such action shall include, but not be limited to, the following: employment, upgrading, demotion or transfer; recruitment or recruitment advertising; layoff or termination; rates of pay or other compensation; and selection for training, including apprenticeship.
4. E-Verify. In accordance with Neb. Rev. Stat. 4-108 through 4-114, the contractor agrees to register with and use a federal immigration verification system, to determine the work eligibility status of new employees performing services within the state of Nebraska. A federal immigration verification system means the electronic verification of the work authorization program of the Illegal Immigration Reform and Immigrant Responsibility Act of 1996, 8 U.S.C. 1324 a, otherwise known as the E-Verify Program, or an equivalent federal program designated by the United States Department of Homeland Security or other federal agency authorized to verify the work eligibility status of a newly hired employee pursuant to the Immigration Reform and Control Act of 1986. The Contractor shall not discriminate against any employee or applicant for employment to be employed in the performance of this section pursuant to the requirements of state law and 8 U.S.C.A 1324b. The contractor shall require any subcontractor to comply with the provisions of this section.
5. Termination. This Contract may be terminated by the following:
 - 5.1) Termination for Convenience. Either party may terminate this Contract upon thirty (30) days written notice to the other party for any reason without penalty.
 - 5.2) Termination for Cause. The Owners may terminate the Contract for cause if the Contractor:
 - 5.2.1) Refuses or fails to supply the proper labor, materials and equipment necessary to provide services and/or commodities.
 - 5.2.2) Disregards Federal, State or local laws, ordinances, regulations, resolutions or orders.
 - 5.2.3) Otherwise commits a substantial breach or default of any provision of the Contract Document. In the event of a substantial breach or default the Owners will provide the Contractor written notice of said breach or default and allow the Contractor ten (10) days from the date of the written notice to cure such breach or default. If said breach or default is not cured within ten (10) days from the date of notice, then the contract shall terminate.
6. Independent Contractor. It is the express intent of the parties that this contract shall not create an employer-employee relationship. Employees of the Contractor shall not be deemed to be employees of the Owners and employees of the Owners shall not be deemed to be employees of the Contractor. The Contractor and the Owners shall be responsible to their respective employees for all salary and benefits. Neither the Contractor's employees nor the Owners' employees shall be entitled to any salary, wages, or benefits from the other party, including but not limited to overtime, vacation, retirement benefits, workers' compensation, sick leave or injury

leave. Contractor shall also be responsible for maintaining workers' compensation insurance, unemployment insurance for its employees, and for payment of all federal, state, local and any other payroll taxes with respect to its employees' compensation.

7. Owner Inclusion. It is understood and agreed by all parties that "Owner/s" shall include the City of Lincoln and Lancaster County, Nebraska. Whenever in the Contract documents, including the instructions to bidders, specifications, insurance requirements, bonds, and terms and conditions or any other documents which are a part of the Contract, a singular entity is referenced (i.e., "the City" or "the County") it shall mean the "Owners" encompassing the City of Lincoln, and Lancaster County. Notwithstanding the foregoing, the duties and obligations of the City and the County pursuant to the Contract shall be treated as divisible and severable duties and obligations, and default by any one of the City or the County shall not be attributed to any other of the Owners, but shall remain the sole obligation of the defaulting entity.
8. Period of Performance. This Contract shall be effective upon execution by all parties. The term of the Contract shall be a one (1) year term with the option to renew for three (3) additional one (1) year terms.
9. The Contract Documents comprise the Contract, and consist of the following:
 1. Contract Terms
 2. Accepted Proposal/Supplier Response
 3. City of Lincoln and Lancaster County Sign Layouts
 4. Special Provisions
 5. Specifications
 6. Instructions to Bidders
 7. Notice to Bidders
 8. Sales Tax Exemption Form 13
(Note: This form cannot be used for the WATER Division of the City of Lincoln. The WATER Division is taxable per Reg. 066.14A or applicable laws.)

The herein above mentioned Contract Documents form this Contract and are a part of the Contract as if hereto attached. Said documents which are not attached to this document may be viewed at: lincoln.ne.gov - Keyword: Bid - Awarded or Closed bids.

The Contractor and the Owners hereby agree that all the terms and conditions of this Contract shall be binding upon themselves, and their heirs, administrators, executors, legal and personal representatives, successors, and assigns.

IN WITNESS WHEREOF, the Contractor and the Owners do hereby execute this contract upon completion of signatures on:

Vendor Signature Page
 City of Lincoln Signature Page
 Lancaster County Signature Page

Vendor Signature Page

**CONTRACT
Annual Supply
Aluminum Sign Blanks
Bid No. 17-240
City of Lincoln and Lancaster County
Vulcan Signs (Vulcan Inc.)**

EXECUTION BY CONTRACTOR

IF A CORPORATION:

Attest:



Secretary David M. Mullins Seal



IF OTHER TYPE OF ORGANIZATION:

Vulcan Inc., dba Vulcan Aluminum

Name of Corporation

PO Box 1850, Foley, AL 36536

Address

By:  J. Todd Koniar

Duly Authorized Official

General Manager

Legal Title of Official

Name of Organization

Type of Organization

Address

By: _____
Member

By: _____
Member

IF AN INDIVIDUAL:

Name

Address

Signature

City of Lincoln Signature Page

**CONTRACT
Annual Supply
Aluminum Sign Blanks
Bid No. 17-240
City of Lincoln and Lancaster County
Vulcan Signs (Vulcan Inc.)**

EXECUTION BY THE CITY OF LINCOLN, NEBRASKA

ATTEST:

City Clerk

CITY OF LINCOLN, NEBRASKA

Public Works and Utilities Director

Approved by Directorial Order No. _____

dated _____

Lancaster County Signature Page

**CONTRACT
Annual Supply
Aluminum Sign Blanks
Bid No. 17-240
City of Lincoln and Lancaster County
Vulcan Signs (Vulcan Inc.)**

EXECUTION BY LANCASTER COUNTY, NEBRASKA

Contract Approved as to Form:

The Board of County Commissioners of
Lancaster, Nebraska

Deputy Lancaster County Attorney

dated _____

City of Lincoln/Lancaster County (Lincoln Purchasing) Supplier Response

Bid Information		Contact Information		Ship to Information
Bid Creator	Sharon Mulder Asst Purchasing Agent	Address	Purchasing 440 S. 8th St. Lincoln, NE 68508	Address
Email	smulder@lincoln.ne.gov	Contact	Sharon R. Mulder Asst Purchasing Agent	Contact
Phone	(402) 441-7428			
Fax	(402) 441-6513			
Bid Number	17-240 Addendum 1	Department	Purchasing	Department
Title	Annual Supply - Aluminum Sign Blanks	Building	Suite 200	Building
Bid Type	Bid	Floor/Room		Floor/Room
Issue Date	8/25/2017 02:48 PM (CT)	Telephone	(402) 441-7428	Telephone
Close Date	9/8/2017 12:00:00 PM (CT)	Fax	(402) 441-6513	Fax
		Email	smulder@lincoln.ne.gov	Email

Supplier Information

Company Vulcan Signs (Vulcan Inc.)
 Address PO Box 1850
 Foley, AL 36536-1850
 Contact J. Todd Koniar
 Department
 Building
 Floor/Room
 Telephone (251) 943-1541
 Fax (251) 943-7590
 Email vulcan1@vulcaninc.com
 Submitted 9/7/2017 08:45:34 AM (CT)
 Total \$16,377.07

By submitting your response, you certify that you are authorized to represent and bind your company.

Signature J. Todd Koniar

Email vulcan1@vulcaninc.com

Supplier Notes

Delivery by common carrier to dock.

Bid Notes

Bid Activities

Bid Messages

Bid Attributes

Please review the following and respond where necessary

#	Name	Note	Response
1	Instructions to Bidders	I acknowledge reading and understanding the Instructions to Bidders.	Yes
2	Sample Contract	I acknowledge reading and understanding the sample contract.	Yes
3	Specifications	I acknowledge reading and understanding the specifications.	Yes
4	Drawings	I acknowledge reading and understanding the Project Drawings.	Yes
5	Delivery	State number of delivery days after receipt of order	30
6	Contact	Name of person submitting this bid:	J. Todd Koniar
7	Kindred Pricing	State the percentage off of the Vendors most current list price to be applied against Kindred Items.	0
8	Renewal is an Option	Contract Extension Renewal is an option.	Yes
9	Special Provision Term Contract Provisions	I acknowledge reading and understanding the Special Provision Term Contract Provisions.	Yes
10	Term Clause of Contract	I acknowledge that the term of the contract is for a one (1) year term with the option for three (3) additional one (1) year renewals from the date of the executed contract. . ((a) Are your bid prices firm for the first one (1) year contract period. YES or NO (b) Are your bid prices subject to escalation/de-escalation YES or NO (c) If (b), state period for which prices will remain firm: through _____	(a) YES (b) YES (c) November 2018
11	Method of Ordering	State your preferred method for ordering.	Email vulcan1@vulcaninc.com
12	Quantities	I acknowledge that the quantities listed for each line item are an estimated yearly amount. The City does not guarantee any dollar amount or order quantities for the term of the contract.	Y
13	Numbers in Price Box	I acknowledge, understand and hereby verify that ONLY numbers have been typed into the Unit Price box in the Line Item section of this ebid response. I further understand that if any symbols or letters (other than a decimal point for dollars and cents) have been typed into the Unit Price box that it will result in my bid showing an amount of \$0 for respective line items.	Yes
14	Bid award	I acknowledge and understand that the City, County and/or Public Building Commission reserves the right to award bids item-by-item, with or without alternates/options, by groups, or "lump sum" such as shall best serve the requirements and interests of the City, County and/or Public Building Commission. If your pricing is based on an all-or-nothing basis, please indicate so in the Supplier Notes section of your E-Bid response.	Yes
15	Electronic Signature	Please check here for your electronic signature.	Yes

- | | | |
|--------------------------------|--|----------------|
| 16 Agreement to Addendum No. 1 | Respondent hereby certifies that the change set forth in this addendum has been incorporated in their proposal and is part of their bid. Reason: Attachment to the Attribute section a Supplier and Date Attribute to complete. | Yes |
| 17 Supplier and Date | The Owner request that each sign include the supplier name and order date (month/year) on the edge of the face. This can be small. Please send sample pdf of what this would look like and where you would put on the sign for approval on the first order. I acknowledge that I have read this and will follow these instructions. Please sign. | Not applicable |

Vulcan, Inc.

410 EAST BERRY AVE P. O. BOX 1850 FOLEY, ALABAMA 36536-1850
(251) 943-7000 FAX (251) 943-9270 e-mail: vulcan@vulcaninc.com



RESOLUTION NO. 147

A RESOLUTION TO AUTHORIZE EMPLOYEES TO SIGN AND EXECUTE BIDS ON BEHALF OF VULCAN, INC.

BE IT RESOLVED by the directors of Vulcan, Inc. while in a regular meeting on December 9, 2016, as follows:

Section 1 - That the following officers and employees of the Corporation are hereby authorized to sign and execute bids on behalf of this Corporation.

Thomas M. Lee	President and Chief Executive Officer
Robert T. Hamlin	Sr. Vice President and Assistant Secretary
James E. Stewart, Jr.	Sr. Vice President and Assistant Secretary
David M. Mullins, Jr.	Chief Financial Officer and Secretary
Harold Perry Judd	Chief Information Officer
Hugh B. Markey	Vice President of Mill Sales
James F. Morris	General Manager
Kathy J. Hawkins	General Manager
Daniel A. Thompson	General Manager
J. Todd Koniar	General Manager
David B. Beviacqua	Sales Manager
Stacy J. Holland	Sales Representative
David R. Lee	Sales Representative

Section 2 - That this Resolution shall become effective as of January 1, 2017.

David M. Mullins
Secretary-Treasurer

Robert W. Lee
Chairman of the Board

I, David M. Mullins, Secretary of Vulcan, Inc., do hereby certify that the foregoing is a true and correct copy of Resolution No. 147, which Resolution was duly and legally adopted at a regular meeting of the Board of Directors of Vulcan, Inc. on December 9, 2016.

David M. Mullins
Secretary

Line Items

#	QTY	UOM								Response
			Sign/Plaque	Size (Inch)			Radius	USD		
				W	x	H			x	T

CITY OF LINCOLN STREET NAME SIGNS: LINE ITEMS 1 - 24 - SEE DRAWING FOR SPECIFICATION

PUNCHED VERTICAL CL 3/8" DIA. 1" FROM TOP AND BOTTOM, HORIZONTAL CL 1/4" DIA. 1" FROM EACH END

1	1	EA	STREET NAME (CITY)	6	x	6	x	0.080	.75"	2.06
2	1	EA	STREET NAME (CITY)	12	x	6	x	0.080	.75"	1.11
3	1	EA	STREET NAME (CITY)	18	x	6	x	0.080	.75"	1.67
4	1	EA	STREET NAME (CITY)	24	x	6	x	0.080	.75"	2.19
5	1	EA	STREET NAME (CITY)	30	x	6	x	0.080	.75"	2.67
6	1	EA	STREET NAME (CITY)	36	x	6	x	0.080	.75"	3.33
7	1	EA	STREET NAME (CITY)	42	x	6	x	0.080	.75"	3.92
8	1	EA	STREET NAME (CITY)	48	x	6	x	0.080	.75"	4.33
9	1	EA	STREET NAME (CITY)	54	x	6	x	0.080	.75"	5.01
10	1	EA	STREET NAME (CITY)	60	x	6	x	0.080	.75"	5.42
11	1	EA	STREET NAME (CITY)	66	x	6	x	0.080	.75"	5.8

12	1	EA	STREET NAME (CITY)	6	x	9	x	0.080	.75"	1.07
13	1	EA	STREET NAME (CITY)	12	x	9	x	0.080	.75"	1.57
14	1	EA	STREET NAME (CITY)	18	x	9	x	0.080	.75"	2.52
15	1	EA	STREET NAME (CITY)	24	x	9	x	0.080	.75"	3.17
16	1	EA	STREET NAME (CITY)	30	x	9	x	0.080	.75"	3.88

17	1	EA	STREET NAME (CITY)	36	x	9	x	0.080	.75"	4.89
18	1	EA	STREET NAME (CITY)	42	x	9	x	0.080	.75"	5.66
19	1	EA	STREET NAME (CITY)	48	x	9	x	0.080	.75"	6.4
20	1	EA	STREET NAME (CITY)	54	x	9	x	0.080	.75"	7.45
21	1	EA	STREET NAME (CITY)	60	x	9	x	0.080	.75"	8.15
22	1	EA	STREET NAME (CITY)	66	x	9	x	0.080	.75"	8.63
23	1	EA	STREET NAME (CITY)	72	x	9	x	0.080	.75"	9.88
24	1	EA	STREET NAME (CITY)	80	x	9	x	0.080	.75"	10.32

LANCASTER COUNTY STREET NAME SIGNS: LINE ITEMS 25 - 48 - SEE DRAWING FOR SPECIFICATION

PUNCHED VERTICAL CL 5/16" DIA., 3/4" FROM TOP AND BOTTOM, HORIZONTAL CL 5/16" DIA., 1/2" FROM EACH END

25	1	EA	STREET NAME (COUNTY)	6	x	6	x	0.080	1.5"	2.06
26	1	EA	STREET NAME (COUNTY)	12	x	6	x	0.080	1.5"	1.11
27	1	EA	STREET NAME (COUNTY)	18	x	6	x	0.080	1.5"	1.67
28	1	EA	STREET NAME (COUNTY)	24	x	6	x	0.080	1.5"	2.19
29	1	EA	STREET NAME (COUNTY)	30	x	6	x	0.080	1.5"	2.67
30	1	EA	STREET NAME (COUNTY)	36	x	6	x	0.080	1.5"	3.33
31	1	EA	STREET NAME (COUNTY)	42	x	6	x	0.080	1.5"	3.92
32	1	EA	STREET NAME (COUNTY)	48	x	6	x	0.080	1.5"	4.33
33	1	EA	STREET NAME (COUNTY)	54	x	6	x	0.080	1.5"	5.01
34	1	EA	STREET NAME (COUNTY)	60	x	6	x	0.080	1.5"	5.42
35	1	EA	STREET NAME (COUNTY)	66	x	6	x	0.080	1.5"	5.8

36	1	EA	STREET NAME (COUNTY)	6	x	9	x	0.080	1.5"	1.07
----	---	----	----------------------	---	---	---	---	-------	------	------

37	1	EA	STREET NAME (COUNTY)	12	x	9	x	0.080	1.5"	1.57
38	1	EA	STREET NAME (COUNTY)	18	x	9	x	0.080	1.5"	2.52
39	1	EA	STREET NAME (COUNTY)	24	x	9	x	0.080	1.5"	3.17
40	1	EA	STREET NAME (COUNTY)	30	x	9	x	0.080	1.5"	3.88
41	1	EA	STREET NAME (COUNTY)	36	x	9	x	0.080	1.5"	4.89
42	1	EA	STREET NAME (COUNTY)	42	x	9	x	0.080	1.5"	5.66
43	1	EA	STREET NAME (COUNTY)	48	x	9	x	0.080	1.5"	6.4
44	1	EA	STREET NAME (COUNTY)	54	x	9	x	0.080	1.5"	7.45
45	1	EA	STREET NAME (COUNTY)	60	x	9	x	0.080	1.5"	8.15
46	1	EA	STREET NAME (COUNTY)	66	x	9	x	0.080	1.5"	8.63
47	1	EA	STREET NAME (COUNTY)	72	x	9	x	0.080	1.5"	9.88
48	1	EA	STREET NAME (COUNTY)	80	x	9	x	0.080	1.5"	10.32

LANCASTER COUNTY ADDRESS SIGNS: LINE ITEMS 49 - 50 - SEE DRAWING FOR SPECIFICATION

PUNCHED (2) 1-1/8" FROM END, 3/8" DIA., 1" FROM TOP AND BOTTOM, (2) 3/8" LOCATED 1.5" FROM TOP AND BOTTOM,
CENTERED ON SHEET

49	1	EA	ADDRESS (COUNTY)	12	x	6	x	0.080	1.5"	1.11
50	1	EA	ADDRESS (COUNTY)	18	x	6	x	0.080	1.5"	1.67

STANDARD MUTCD SIGN BLANKS: LINE ITEMS 51 - 251

WITH OR WITHOUT STANDARD HOLE PUNCH (SPECIFIED ON ORDER), STANDARD RADIUS (CITY & COUNTY)

51	1	EA	GUIDE SIGN, DESTINATION, STREET NAME, OTHER	6	x	12	x	0.080	Std	1.19
52	1	EA	GUIDE SIGN, DESTINATION, STREET NAME, OTHER	9	x	12	x	0.080	Std	1.65
53	1	EA	GUIDE SIGN, DESTINATION, STREET NAME, OTHER	12	x	12	x	0.080	Std	2.07
54	1	EA	GUIDE SIGN, DESTINATION, STREET NAME, OTHER	18	x	12	x	0.080	Std	3.11

55	1	EA	GUIDE SIGN, DESTINATION, STREET NAME, OTHER	24	x	12	x	0.080	Std	4.23
56	1	EA	GUIDE SIGN, DESTINATION, STREET NAME, OTHER	30	x	12	x	0.080	Std	5.41
57	1	EA	GUIDE SIGN, DESTINATION, STREET NAME, OTHER	36	x	12	x	0.080	Std	6.44
58	1	EA	GUIDE SIGN, DESTINATION, STREET NAME, OTHER	42	x	12	x	0.080	Std	7.42
59	1	EA	GUIDE SIGN, DESTINATION, STREET NAME, OTHER	48	x	12	x	0.080	Std	8.49
60	1	EA	GUIDE SIGN, DESTINATION, STREET NAME, OTHER	54	x	12	x	0.080	Std	9.55
61	1	EA	GUIDE SIGN, DESTINATION, STREET NAME, OTHER	60	x	12	x	0.080	Std	10.53
62	1	EA	GUIDE SIGN, DESTINATION, STREET NAME, OTHER	66	x	12	x	0.080	Std	12.12
63	1	EA	GUIDE SIGN, DESTINATION, STREET NAME, OTHER	72	x	12	x	0.080	Std	12.86
64	1	EA	GUIDE SIGN, DESTINATION, STREET NAME, OTHER	78	x	12	x	0.080	Std	13.93
65	1	EA	GUIDE SIGN, DESTINATION, STREET NAME, OTHER	84	x	12	x	0.080	Std	15.12
66	1	EA	GUIDE SIGN, DESTINATION, STREET NAME, OTHER	90	x	12	x	0.080	Std	16.15
67	1	EA	GUIDE SIGN, DESTINATION, STREET NAME, OTHER	96	x	12	x	0.080	Std	17.38
68	1	EA	GUIDE SIGN, DESTINATION, STREET NAME, OTHER	102	x	12	x	0.080	Std	17.73
69	1	EA	GUIDE SIGN, DESTINATION, STREET NAME, OTHER	108	x	12	x	0.080	Std	19.12
70	1	EA	GUIDE SIGN, DESTINATION, STREET NAME, OTHER	114	x	12	x	0.080	Std	20.1
71	1	EA	GUIDE SIGN, DESTINATION, STREET NAME, OTHER	120	x	12	x	0.080	Std	21.1

72	1	EA	GUIDE SIGN, DESTINATION, STREET NAME, OTHER	6	x	18	x	0.080	Std	1.67
73	1	EA	GUIDE SIGN, DESTINATION, STREET NAME, OTHER	9	x	18	x	0.080	Std	2.52
74	1	EA	GUIDE SIGN, DESTINATION, STREET NAME, OTHER	12	x	18	x	0.080	Std	3.11
75	1	EA	GUIDE SIGN, DESTINATION, STREET NAME, OTHER	18	x	18	x	0.080	Std	4.66
76	1	EA	GUIDE SIGN, DESTINATION, STREET NAME, OTHER	24	x	18	x	0.080	Std	6.22

77	1	EA	GUIDE SIGN, DESTINATION, STREET NAME, OTHER	30	x	18	x	0.080	Std	8.04
78	1	EA	GUIDE SIGN, DESTINATION, STREET NAME, OTHER	36	x	18	x	0.080	Std	9.56
79	1	EA	GUIDE SIGN, DESTINATION, STREET NAME, OTHER	42	x	18	x	0.080	Std	11.12
80	1	EA	GUIDE SIGN, DESTINATION, STREET NAME, OTHER	48	x	18	x	0.080	Std	12.64
81	1	EA	GUIDE SIGN, DESTINATION, STREET NAME, OTHER	54	x	18	x	0.080	Std	14.24
82	1	EA	GUIDE SIGN, DESTINATION, STREET NAME, OTHER	60	x	18	x	0.080	Std	15.89
83	1	EA	GUIDE SIGN, DESTINATION, STREET NAME, OTHER	66	x	18	x	0.080	Std	17.43
84	1	EA	GUIDE SIGN, DESTINATION, STREET NAME, OTHER	72	x	18	x	0.080	Std	19.12
85	1	EA	GUIDE SIGN, DESTINATION, STREET NAME, OTHER	78	x	18	x	0.080	Std	20.85
86	1	EA	GUIDE SIGN, DESTINATION, STREET NAME, OTHER	84	x	18	x	0.080	Std	22.41
87	1	EA	GUIDE SIGN, DESTINATION, STREET NAME, OTHER	90	x	18	x	0.080	Std	24.06
88	1	EA	GUIDE SIGN, DESTINATION, STREET NAME, OTHER	96	x	18	x	0.080	Std	26.01
89	1	EA	GUIDE SIGN, DESTINATION, STREET NAME, OTHER	102	x	18	x	0.080	Std	27.52
90	1	EA	GUIDE SIGN, DESTINATION, STREET NAME, OTHER	108	x	18	x	0.080	Std	28.98
91	1	EA	GUIDE SIGN, DESTINATION, STREET NAME, OTHER	114	x	18	x	0.080	Std	30.33
92	1	EA	GUIDE SIGN, DESTINATION, STREET NAME, OTHER	120	x	18	x	0.080	Std	32.9
93	1	EA	GUIDE SIGN, DESTINATION, STREET NAME, OTHER	126	x	18	x	0.080	Std	33.8
94	1	EA	GUIDE SIGN, DESTINATION, STREET NAME, OTHER	132	x	18	x	0.080	Std	35.29
95	1	EA	GUIDE SIGN, DESTINATION, STREET NAME, OTHER	138	x	18	x	0.080	Std	36.9
95	1	EA	GUIDE SIGN, DESTINATION, STREET NAME, OTHER	144	x	18	x	0.080	Std	35.87

96	1	EA	GUIDE SIGN, DESTINATION, STREET NAME, OTHER	6	x	20	x	0.080	Std	1.9
97	1	EA	GUIDE SIGN, DESTINATION, STREET NAME, OTHER	9	x	20	x	0.080	Std	2.68

98	1	EA	GUIDE SIGN, DESTINATION, STREET NAME, OTHER	12	x	20	x	0.080	Std	3.6
99	1	EA	GUIDE SIGN, DESTINATION, STREET NAME, OTHER	18	x	20	x	0.080	Std	5.15
100	1	EA	GUIDE SIGN, DESTINATION, STREET NAME, OTHER	24	x	20	x	0.080	Std	6.79
101	1	EA	GUIDE SIGN, DESTINATION, STREET NAME, OTHER	30	x	20	x	0.080	Std	8.91
102	1	EA	GUIDE SIGN, DESTINATION, STREET NAME, OTHER	36	x	20	x	0.080	Std	10.6
103	1	EA	GUIDE SIGN, DESTINATION, STREET NAME, OTHER	42	x	20	x	0.080	Std	11.76
104	1	EA	GUIDE SIGN, DESTINATION, STREET NAME, OTHER	48	x	20	x	0.080	Std	14.05
105	1	EA	GUIDE SIGN, DESTINATION, STREET NAME, OTHER	54	x	20	x	0.080	Std	15.12
106	1	EA	GUIDE SIGN, DESTINATION, STREET NAME, OTHER	60	x	20	x	0.080	Std	16.82
107	1	EA	GUIDE SIGN, DESTINATION, STREET NAME, OTHER	66	x	20	x	0.080	Std	20.11
108	1	EA	GUIDE SIGN, DESTINATION, STREET NAME, OTHER	72	x	20	x	0.080	Std	20.17
109	1	EA	GUIDE SIGN, DESTINATION, STREET NAME, OTHER	78	x	20	x	0.080	Std	22.91
110	1	EA	GUIDE SIGN, DESTINATION, STREET NAME, OTHER	84	x	20	x	0.080	Std	29.14
111	1	EA	GUIDE SIGN, DESTINATION, STREET NAME, OTHER	90	x	20	x	0.080	Std	25.37
112	1	EA	GUIDE SIGN, DESTINATION, STREET NAME, OTHER	96	x	20	x	0.080	Std	27.86
113	1	EA	GUIDE SIGN, DESTINATION, STREET NAME, OTHER	102	x	20	x	0.080	Std	34.76
114	1	EA	GUIDE SIGN, DESTINATION, STREET NAME, OTHER	108	x	20	x	0.080	Std	36.31
115	1	EA	GUIDE SIGN, DESTINATION, STREET NAME, OTHER	114	x	20	x	0.080	Std	38.8
116	1	EA	GUIDE SIGN, DESTINATION, STREET NAME, OTHER	120	x	20	x	0.080	Std	33.79
117	1	EA	GUIDE SIGN, DESTINATION, STREET NAME, OTHER	126	x	20	x	0.080	Std	8.92
118	1	EA	GUIDE SIGN, DESTINATION, STREET NAME, OTHER	132	x	20	x	0.080	Std	43.39
119	1	EA	GUIDE SIGN, DESTINATION, STREET NAME, OTHER	138	x	20	x	0.080	Std	9.77
120	1	EA	GUIDE SIGN, DESTINATION, STREET NAME, OTHER	144	x	20	x	0.080	Std	43.39

121	1	EA	GUIDE SIGN, DESTINATION, STREET NAME, OTHER	6	x	24	x	0.080	Std	2.19
122	1	EA	GUIDE SIGN, DESTINATION, STREET NAME, OTHER	9	x	24	x	0.080	Std	3.17
123	1	EA	GUIDE SIGN, DESTINATION, STREET NAME, OTHER	12	x	24	x	0.080	Std	4.3
124	1	EA	GUIDE SIGN, DESTINATION, STREET NAME, OTHER	18	x	24	x	0.080	Std	6.22
125	1	EA	GUIDE SIGN, DESTINATION, STREET NAME, OTHER	24	x	24	x	0.080	Std	8.29
126	1	EA	GUIDE SIGN, DESTINATION, STREET NAME, OTHER	30	x	24	x	0.080	Std	10.36
127	1	EA	GUIDE SIGN, DESTINATION, STREET NAME, OTHER	36	x	24	x	0.080	Std	12.33
128	1	EA	GUIDE SIGN, DESTINATION, STREET NAME, OTHER	42	x	24	x	0.080	Std	14.65
129	1	EA	GUIDE SIGN, DESTINATION, STREET NAME, OTHER	48	x	24	x	0.080	Std	16.74
130	1	EA	GUIDE SIGN, DESTINATION, STREET NAME, OTHER	54	x	24	x	0.080	Std	18.79
131	1	EA	GUIDE SIGN, DESTINATION, STREET NAME, OTHER	60	x	24	x	0.080	Std	20.89
132	1	EA	GUIDE SIGN, DESTINATION, STREET NAME, OTHER	66	x	24	x	0.080	Std	22.95
133	1	EA	GUIDE SIGN, DESTINATION, STREET NAME, OTHER	72	x	24	x	0.080	Std	25.24
134	1	EA	GUIDE SIGN, DESTINATION, STREET NAME, OTHER	78	x	24	x	0.080	Std	27.45
135	1	EA	GUIDE SIGN, DESTINATION, STREET NAME, OTHER	84	x	24	x	0.080	Std	28.41
136	1	EA	GUIDE SIGN, DESTINATION, STREET NAME, OTHER	90	x	24	x	0.080	Std	31.54
137	1	EA	GUIDE SIGN, DESTINATION, STREET NAME, OTHER	96	x	24	x	0.080	Std	33.98
138	1	EA	GUIDE SIGN, DESTINATION, STREET NAME, OTHER	102	x	24	x	0.080	Std	36.73
139	1	EA	GUIDE SIGN, DESTINATION, STREET NAME, OTHER	108	x	24	x	0.080	Std	37.12
140	1	EA	GUIDE SIGN, DESTINATION, STREET NAME, OTHER	114	x	24	x	0.080	Std	39.35
141	1	EA	GUIDE SIGN, DESTINATION, STREET NAME, OTHER	120	x	24	x	0.080	Std	42.24
142	1	EA	GUIDE SIGN, DESTINATION, STREET NAME, OTHER	126	x	24	x	0.080	Std	44.1

143	1	EA	GUIDE SIGN, DESTINATION, STREET NAME, OTHER	132	x	24	x	0.080	Std	46.15
144	1	EA	GUIDE SIGN, DESTINATION, STREET NAME, OTHER	138	x	24	x	0.080	Std	46.78
145	1	EA	GUIDE SIGN, DESTINATION, STREET NAME, OTHER	144	x	24	x	0.080	Std	49.32

146	1	EA	GUIDE SIGN, DESTINATION, STREET NAME, OTHER	6	x	30	x	0.080	Std	2.67
147	1	EA	GUIDE SIGN, DESTINATION, STREET NAME, OTHER	9	x	30	x	0.080	Std	3.88
148	1	EA	GUIDE SIGN, DESTINATION, STREET NAME, OTHER	12	x	30	x	0.080	Std	5.41
149	1	EA	GUIDE SIGN, DESTINATION, STREET NAME, OTHER	18	x	30	x	0.080	Std	8.04
150	1	EA	GUIDE SIGN, DESTINATION, STREET NAME, OTHER	24	x	30	x	0.080	Std	10.36
151	1	EA	GUIDE SIGN, DESTINATION, STREET NAME, OTHER	30	x	30	x	0.080	Std	12.99
152	1	EA	GUIDE SIGN, DESTINATION, STREET NAME, OTHER	36	x	30	x	0.080	Std	15.89
153	1	EA	GUIDE SIGN, DESTINATION, STREET NAME, OTHER	42	x	30	x	0.080	Std	18.6
154	1	EA	GUIDE SIGN, DESTINATION, STREET NAME, OTHER	48	x	30	x	0.080	Std	20.92
155	1	EA	GUIDE SIGN, DESTINATION, STREET NAME, OTHER	54	x	30	x	0.080	Std	23.84
156	1	EA	GUIDE SIGN, DESTINATION, STREET NAME, OTHER	60	x	30	x	0.080	Std	26.48
157	1	EA	GUIDE SIGN, DESTINATION, STREET NAME, OTHER	66	x	30	x	0.080	Std	29.3
158	1	EA	GUIDE SIGN, DESTINATION, STREET NAME, OTHER	72	x	30	x	0.080	Std	31.94
159	1	EA	GUIDE SIGN, DESTINATION, STREET NAME, OTHER	78	x	30	x	0.080	Std	34.7
160	1	EA	GUIDE SIGN, DESTINATION, STREET NAME, OTHER	84	x	30	x	0.080	Std	37.17
161	1	EA	GUIDE SIGN, DESTINATION, STREET NAME, OTHER	90	x	30	x	0.080	Std	39.78
162	1	EA	GUIDE SIGN, DESTINATION, STREET NAME, OTHER	96	x	30	x	0.080	Std	42.84
163	1	EA	GUIDE SIGN, DESTINATION, STREET NAME, OTHER	102	x	30	x	0.080	Std	45.25
164	1	EA	GUIDE SIGN, DESTINATION, STREET NAME, OTHER	108	x	30	x	0.080	Std	49.64

165	1	EA	GUIDE SIGN, DESTINATION, STREET NAME, OTHER	114	x	30	x	0.080	Std	49.84
166	1	EA	GUIDE SIGN, DESTINATION, STREET NAME, OTHER	120	x	30	x	0.080	Std	52.24
167	1	EA	GUIDE SIGN, DESTINATION, STREET NAME, OTHER	126	x	30	x	0.080	Std	55.87
168	1	EA	GUIDE SIGN, DESTINATION, STREET NAME, OTHER	132	x	30	x	0.080	Std	57.47
169	1	EA	GUIDE SIGN, DESTINATION, STREET NAME, OTHER	138	x	30	x	0.080	Std	58.4
170	1	EA	GUIDE SIGN, DESTINATION, STREET NAME, OTHER	144	x	30	x	0.080	Std	62.69

170	1	EA	GUIDE SIGN, DESTINATION, STREET NAME, OTHER	6	x	36	x	0.080	Std	3.33
171	1	EA	GUIDE SIGN, DESTINATION, STREET NAME, OTHER	9	x	36	x	0.080	Std	4.89
172	1	EA	GUIDE SIGN, DESTINATION, STREET NAME, OTHER	12	x	36	x	0.080	Std	6.44
173	1	EA	GUIDE SIGN, DESTINATION, STREET NAME, OTHER	18	x	36	x	0.080	Std	9.56
174	1	EA	GUIDE SIGN, DESTINATION, STREET NAME, OTHER	24	x	36	x	0.080	Std	12.33
175	1	EA	GUIDE SIGN, DESTINATION, STREET NAME, OTHER	30	x	36	x	0.080	Std	15.62
176	1	EA	GUIDE SIGN, DESTINATION, STREET NAME, OTHER	36	x	36	x	0.080	Std	18.96
177	1	EA	GUIDE SIGN, DESTINATION, STREET NAME, OTHER	42	x	36	x	0.080	Std	22.16
178	1	EA	GUIDE SIGN, DESTINATION, STREET NAME, OTHER	48	x	36	x	0.080	Std	25.18
179	1	EA	GUIDE SIGN, DESTINATION, STREET NAME, OTHER	54	x	36	x	0.080	Std	28.59
180	1	EA	GUIDE SIGN, DESTINATION, STREET NAME, OTHER	60	x	36	x	0.080	Std	31.67
181	1	EA	GUIDE SIGN, DESTINATION, STREET NAME, OTHER	66	x	36	x	0.080	Std	33.37
182	1	EA	GUIDE SIGN, DESTINATION, STREET NAME, OTHER	72	x	36	x	0.080	Std	38.42
183	1	EA	GUIDE SIGN, DESTINATION, STREET NAME, OTHER	78	x	36	x	0.080	Std	39.91
184	1	EA	GUIDE SIGN, DESTINATION, STREET NAME, OTHER	84	x	36	x	0.080	Std	44.49
185	1	EA	GUIDE SIGN, DESTINATION, STREET NAME, OTHER	90	x	36	x	0.080	Std	45.69

186	1	EA	GUIDE SIGN, DESTINATION, STREET NAME, OTHER	96	x	36	x	0.080	Std	50.98
187	1	EA	GUIDE SIGN, DESTINATION, STREET NAME, OTHER	102	x	36	x	0.080	Std	50.68
188	1	EA	GUIDE SIGN, DESTINATION, STREET NAME, OTHER	108	x	36	x	0.080	Std	53.59
189	1	EA	GUIDE SIGN, DESTINATION, STREET NAME, OTHER	114	x	36	x	0.080	Std	61.9
190	1	EA	GUIDE SIGN, DESTINATION, STREET NAME, OTHER	120	x	36	x	0.080	Std	62.3
191	1	EA	GUIDE SIGN, DESTINATION, STREET NAME, OTHER	126	x	36	x	0.080	Std	62.59
192	1	EA	GUIDE SIGN, DESTINATION, STREET NAME, OTHER	132	x	36	x	0.080	Std	68.09
193	1	EA	GUIDE SIGN, DESTINATION, STREET NAME, OTHER	138	x	36	x	0.080	Std	68.75
194	1	EA	GUIDE SIGN, DESTINATION, STREET NAME, OTHER	144	x	36	x	0.080	Std	71.54

195	1	EA	GUIDE SIGN, DESTINATION, STREET NAME, OTHER	6	x	42	x	0.080	Std	3.92
196	1	EA	GUIDE SIGN, DESTINATION, STREET NAME, OTHER	9	x	42	x	0.080	Std	5.82
197	1	EA	GUIDE SIGN, DESTINATION, STREET NAME, OTHER	12	x	42	x	0.080	Std	7.4
198	1	EA	GUIDE SIGN, DESTINATION, STREET NAME, OTHER	18	x	42	x	0.080	Std	11.1
199	1	EA	GUIDE SIGN, DESTINATION, STREET NAME, OTHER	24	x	42	x	0.080	Std	14.66
200	1	EA	GUIDE SIGN, DESTINATION, STREET NAME, OTHER	30	x	42	x	0.080	Std	18.57
201	1	EA	GUIDE SIGN, DESTINATION, STREET NAME, OTHER	36	x	42	x	0.080	Std	22.16
202	1	EA	GUIDE SIGN, DESTINATION, STREET NAME, OTHER	42	x	42	x	0.080	Std	26.24
203	1	EA	GUIDE SIGN, DESTINATION, STREET NAME, OTHER	48	x	42	x	0.080	Std	29.4
204	1	EA	GUIDE SIGN, DESTINATION, STREET NAME, OTHER	54	x	42	x	0.080	Std	32.13
205	1	EA	GUIDE SIGN, DESTINATION, STREET NAME, OTHER	60	x	42	x	0.080	Std	35.34
206	1	EA	GUIDE SIGN, DESTINATION, STREET NAME, OTHER	66	x	42	x	0.080	Std	38.86
207	1	EA	GUIDE SIGN, DESTINATION, STREET NAME, OTHER	72	x	42	x	0.080	Std	42.73

208	1	EA	GUIDE SIGN, DESTINATION, STREET NAME, OTHER	78	x	42	x	0.080	Std	49.37
209	1	EA	GUIDE SIGN, DESTINATION, STREET NAME, OTHER	84	x	42	x	0.080	Std	51.93
210	1	EA	GUIDE SIGN, DESTINATION, STREET NAME, OTHER	90	x	42	x	0.080	Std	52.2
211	1	EA	GUIDE SIGN, DESTINATION, STREET NAME, OTHER	96	x	42	x	0.080	Std	59.23
212	1	EA	GUIDE SIGN, DESTINATION, STREET NAME, OTHER	102	x	42	x	0.080	Std	61.53
213	1	EA	GUIDE SIGN, DESTINATION, STREET NAME, OTHER	108	x	42	x	0.080	Std	67.37
214	1	EA	GUIDE SIGN, DESTINATION, STREET NAME, OTHER	114	x	42	x	0.080	Std	65.98
215	1	EA	GUIDE SIGN, DESTINATION, STREET NAME, OTHER	120	x	42	x	0.080	Std	69.17
216	1	EA	GUIDE SIGN, DESTINATION, STREET NAME, OTHER	126	x	42	x	0.080	Std	72.83
217	1	EA	GUIDE SIGN, DESTINATION, STREET NAME, OTHER	132	x	42	x	0.080	Std	19.14
218	1	EA	GUIDE SIGN, DESTINATION, STREET NAME, OTHER	138	x	42	x	0.080	Std	79.83
219	1	EA	GUIDE SIGN, DESTINATION, STREET NAME, OTHER	144	x	42	x	0.080	Std	86.84

220	1	EA	GUIDE SIGN, DESTINATION, STREET NAME, OTHER	6	x	48	x	0.080	Std	4.33
221	1	EA	GUIDE SIGN, DESTINATION, STREET NAME, OTHER	9	x	48	x	0.080	Std	6.43
222	1	EA	GUIDE SIGN, DESTINATION, STREET NAME, OTHER	12	x	48	x	0.080	Std	8.47
223	1	EA	GUIDE SIGN, DESTINATION, STREET NAME, OTHER	18	x	48	x	0.080	Std	12.64
224	1	EA	GUIDE SIGN, DESTINATION, STREET NAME, OTHER	24	x	48	x	0.080	Std	16.74
225	1	EA	GUIDE SIGN, DESTINATION, STREET NAME, OTHER	30	x	48	x	0.080	Std	20.85
226	1	EA	GUIDE SIGN, DESTINATION, STREET NAME, OTHER	36	x	48	x	0.080	Std	25.18
227	1	EA	GUIDE SIGN, DESTINATION, STREET NAME, OTHER	42	x	48	x	0.080	Std	29.4
228	1	EA	GUIDE SIGN, DESTINATION, STREET NAME, OTHER	48	x	48	x	0.080	Std	33.41
229	1	EA	GUIDE SIGN, DESTINATION, STREET NAME, OTHER	54	x	48	x	0.080	Std	37.7

230	1	EA	GUIDE SIGN, DESTINATION, STREET NAME, OTHER	60	x	48	x	0.080	Std	41.76
231	1	EA	GUIDE SIGN, DESTINATION, STREET NAME, OTHER	66	x	48	x	0.080	Std	44.11
232	1	EA	GUIDE SIGN, DESTINATION, STREET NAME, OTHER	72	x	48	x	0.080	Std	50.33
233	1	EA	GUIDE SIGN, DESTINATION, STREET NAME, OTHER	78	x	48	x	0.080	Std	53.15
234	1	EA	GUIDE SIGN, DESTINATION, STREET NAME, OTHER	84	x	48	x	0.080	Std	56.39
235	1	EA	GUIDE SIGN, DESTINATION, STREET NAME, OTHER	90	x	48	x	0.080	Std	62.51
236	1	EA	GUIDE SIGN, DESTINATION, STREET NAME, OTHER	96	x	48	x	0.080	Std	65.87
237	1	EA	GUIDE SIGN, DESTINATION, STREET NAME, OTHER	102	x	48	x	0.080	Std	69.95
238	1	EA	GUIDE SIGN, DESTINATION, STREET NAME, OTHER	108	x	48	x	0.080	Std	76.64
239	1	EA	GUIDE SIGN, DESTINATION, STREET NAME, OTHER	114	x	48	x	0.080	Std	75.26
240	1	EA	GUIDE SIGN, DESTINATION, STREET NAME, OTHER	120	x	48	x	0.080	Std	82.21
241	1	EA	GUIDE SIGN, DESTINATION, STREET NAME, OTHER	126	x	48	x	0.080	Std	83.07
242	1	EA	GUIDE SIGN, DESTINATION, STREET NAME, OTHER	132	x	48	x	0.080	Std	87.03
243	1	EA	GUIDE SIGN, DESTINATION, STREET NAME, OTHER	138	x	48	x	0.080	Std	90.98
244	1	EA	GUIDE SIGN, DESTINATION, STREET NAME, OTHER	144	x	48	x	0.080	Std	98.66

245	250	EA	STOP(Octagon)	30	x	30	x	0.080		11.59
246	250	EA	STOP(Octagon)	36	x	36	x	0.080		16.9
247	100	EA	YIELD (Triangle)	36	x	36	x	0.080		9.06
248	10	EA	INTERSTATE ROUTE SIGN (1-2 DIGITS)	24	x	24	x	0.080		8.01
249	10	EA	INTERSTATE ROUTE SIGN (3 DIGITS)	24	x	30	x	0.080		11.99
250	100	EA	SCHOOL ADVANCE (Pentagon)	36	x	36	x	0.080		16.2
251	25	EA	GRADE CROSSING ADVANCE WARNING(Round)	36	x	36	x	0.080		18.37

SPECIALITY - SEE DRAWING FOR SPECIFICATION

252	1	EA	DUAL SIGN MOUNTING PLATE - 6 HOLE PUNCHED	18	x	18	x	0.063	Std	4.03
-----	---	----	---	----	---	----	---	-------	-----	------

LINE ITEMS 252 - 255 ARE FOR COSTING/ORDERING OF ANY SIGN BLANK

ALUMINUM PLATE W/W/O STANDARD HOLE PUNCH SPECIFIED AT QUOTE OR ORDER

253	1	SF	ALUMINUM FOR SIGN FABRICATION	12	x	12	x	0.063		1.69
254	1	SF	ALUMINUM FOR SIGN FABRICATION	12	x	12	x	0.080		2.12
255	1	SF	ALUMINUM FOR SIGN FABRICATION	12	x	12	x	0.100		2.65
256	1	SF	ALUMINUM FOR SIGN FABRICATION	12	x	12	x	0.125		3.31

LINE ITEMS 256-261 ARE APPLICABLE TO ALL SIGNS

257	1	SF	PLATE THICKNESS UPCHARGE FROM 0.08 TO 0.1	12	x	12				0.53
258	1	SF	PLATE THICKNESS UPCHARGE FROM 0.08 TO 0.125	12	x	12				1.19
259	1	SF	PLATE THICKNESS UPCHARGE FROM 0.100 TO 0.125	12	x	12				0.66
260	1	EA	ADDITIONAL HOLE PUNCH, 4 OR LESS (BEYOND STANDARD MOUNT)							0.05
261	1	EA	ADDITIONAL HOLE PUNCH, 5 TO 9 (BEYOND STANDARD MOUNT)							0.1
262	1	EA	ADDITIONAL HOLE PUNCH, 10 PLUS (BEYOND STANDARD MOUNT)							0.1

MINIMUM ORDER IN USD TO AVOID ADDITIONAL SHIPPING COSTS

263	1	EA	LESS THAN MINIMUM ORDER FREIGHT CHARGE (UPS/FED EX GROUND)							250
264	1	EA	LESS THAN MINIMUM ORDER FREIGHT CHARGE (TRUCK)							2000

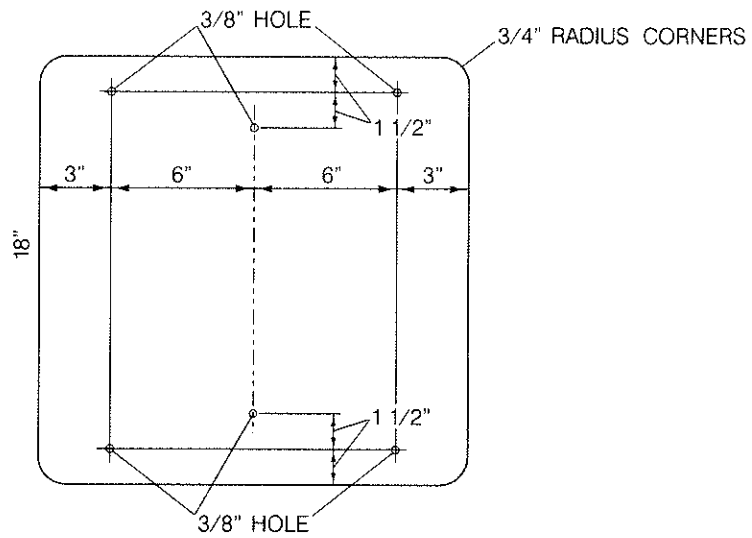

DUAL SIGN MOUNTING PLATE

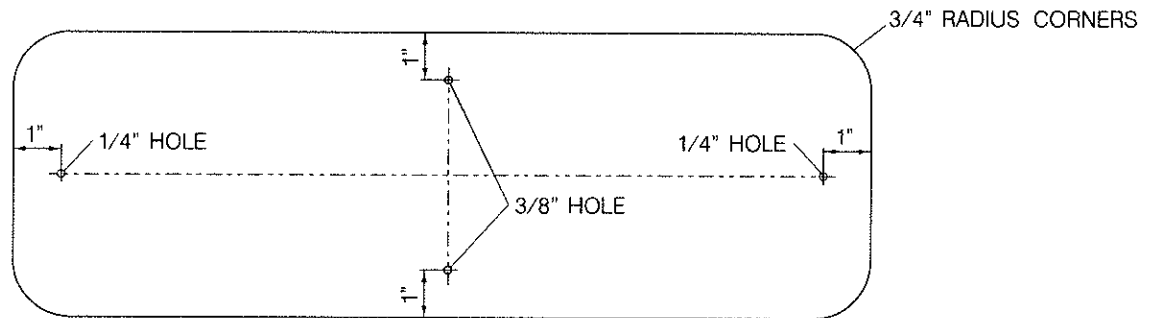

STREET NAME PLATE

**CITY OF LINCOLN, NEBRASKA
SPECIFICATIONS FOR SIGNS**

6" and 9" high signs with widths of 24, 30, 36, 42, 48, 54, and 60 inches
 Use 5/16" hole size, 4 holes total, 2 of these are 1/2" in from each end and centered.
 The other 2 holes located 3/4" up/down in the center of the sheet.
 The Radius is 1.5 inch, gauge of aluminum .080"

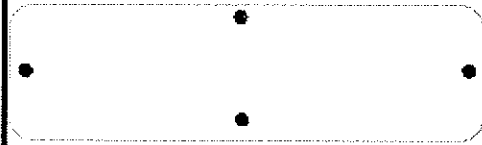

24,30,36,42,48,54x9 street signs
 24,30,36,42,48x6 signs

2 - 3/8" holes located 1" up/down and 1 1/8" from edge.
 2 - 3/8" holes located 1.5" up/down and centered on sheet.
 The Radius is 1.5 inch, gauge of aluminum .080"

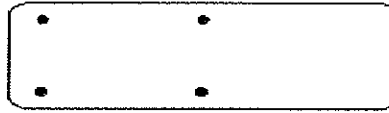

18x6 Address signs/
 All Way



36x36 30x30

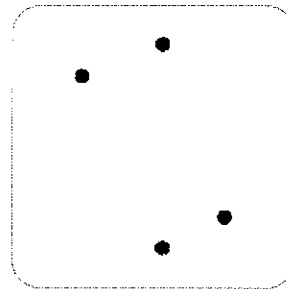

18x18

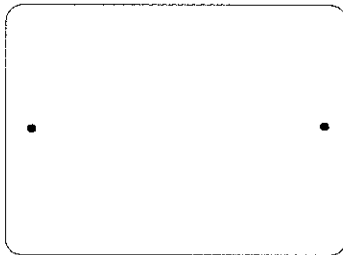

36x30

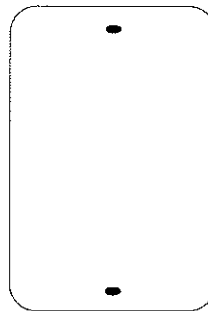

12x36 Hazard marker/ object marker
 24x30 3/8" holes
 24x36

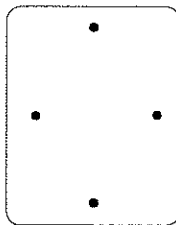

12x24 12x30 18x24
 5/16 holes 3/8 holes

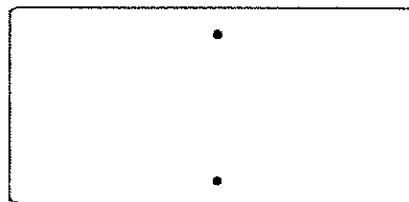

48x24

36"
yield

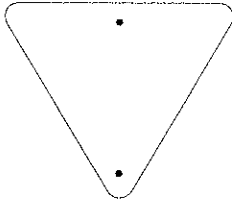

30" & 36" stop

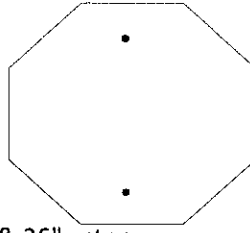

12x6
3 spot marker
holes 1/2" from all sides



**SPECIAL PROVISIONS
FOR
TERM CONTRACTS**

**PURCHASING DEPARTMENT
CITY OF LINCOLN/LANCASTER COUNTY, NEBRASKA**

1. ESTIMATED QUANTITIES

- 1.1 The quantities set forth in the line items and specification document are approximate and represent the estimated requirements for the contract period.
- 1.2 Items listed may or may not be an inclusive requirements for this category.
- 1.3 Category items not listed, but distributed by bidder are to be referred to as kindred items. Kindred items shall receive the same percentage of discount or pricing structure as items listed in the specification document.
- 1.4 The unit prices and the extended total prices shall be used as a basis for the evaluation of bids. The actual quantity of materials necessary may be more or less than the estimates listed in the specification document, but the City/County shall be neither obligated nor limited to any specified amount. If possible, the Owners will restrict increases/decreases to 20% of the estimated quantities listed in the specification document.

2. CONTRACT PERIOD

- 2.1 The material shall be delivered as ordered during the contract period, beginning from the date of contract execution and ending as indicated in the specifications or in the Attribute Section of the bid.
- 2.2 Bidder must indicate in the Bid, if extension renewals are an option.
- 2.3 By mutual consent of both parties it is understood and agreed that the contract may be renewed at the same prices and/or under the same conditions governing the original contract.

3. BID PRICES

- 3.1 Bidders must state in the Attribute Section if the bid prices will remain firm for the full contract period; or if the bid prices will be subject to escalation/de-escalation.
- 3.2 Escalation/De-escalation Clause: In the event that prevailing market conditions warrant an adjustment in bid prices contained in the contract, the following escalation/de-escalation clause shall be the only clause applicable or acceptable:
 1. Contractor shall give written notice to the Purchasing Agent of any proposed changes from contract prices not less than thirty (30) calendar days prior to the effective date of said price changes.
 2. Such notice must be accompanied by a certified copy of the supplier's advisory or notification to the contractor of price changes.
 3. No price escalation will be authorized in excess of the amount of the increase referred to on the supplier's notice.
 4. Purchasing shall issue a contract Addendum with revised pricing upon receipt and approval. The Addendum will be executed by both parties for the remaining term of the contract.
 5. The approved price change shall be honored for all orders received by the contractor after the effective date of such price change.
 6. Approved price changes are not applicable to orders already issued and in process at time of price change.

7. Purchasing reserves the right to audit and/or examine any pertinent books, documents, papers, records or invoices relating directly to the contract transaction in question after reasonable notice and during normal business hours.
8. The Purchasing Agent retains the right to determine whether or not such proposed price changes are in the best interests of the City/County.
9. If in the opinion of the Purchasing Agent any proposed increase is found unacceptable, the Purchasing Agent reserves the right to cancel the contract upon thirty (30) calendar days written notice.
10. Contractors must tie any price change clause to an industry-wide or otherwise nationally recognized index, or some other form of verifiable document. Contractor will put the Purchasing Agent on the mailing lists for such publication so that the Purchasing Agent can monitor said changes. Such membership will be no cost to the Owners.

4. CONTRACT ADMINISTRATION

- 4.1 The Purchasing Division will issue a Contract to all successful bidders. Such contract will incorporate the specifications and all other forms used during the bid process.
- 4.2 Orders for materials will be made as needed by the various Agencies following execution by all parties.
- 4.3 Contractor may be asked to assist the Purchasing Agent with the development of a list of repetitively purchased commodities, to periodically update such list, and to assist in the development of a list of suitable substitutions.
- 4.4 Contractor shall provide technical advice upon request, and assist in the evaluation of new products.
- 4.5 Contractor shall monitor orders to ensure the highest possible fill rate and minimize back-orders.

5. QUARTERLY REPORT

- 5.1 Upon request, the contractor shall provide to the Purchasing Agent a quarterly report, showing all purchases made under the terms and conditions of the contract.
- 5.2 Such quarterly report shall itemize the following information:
 1. Each ordering department.
 2. Items and quantities purchased by department.
 3. Total dollar amount of purchases by department.

ANNUAL REQUIREMENTS ALUMINUM SIGN BLANKS

1. SUPPLEMENTAL INSTRUCTIONS

- 1.1 The City of Lincoln and Lancaster County are requesting bids to purchase Aluminum Sign Blanks to enter into an annual supply contract.
- 1.2 Bidder shall submit bid documents and all supporting material via e-bid.
- 1.3 All inquiries regarding these specifications shall be directed via e-mail or faxed written request to Sharon Mulder, Asst. Purchasing Agent (smulder@lincoln.ne.gov) or fax: (402) 441-6513.
 - 1.3.1 These inquiries and/or responses shall be distributed to prospective bidders electronically as an addenda.
 - 1.3.2 The Purchasing Office shall only reply to written inquiries received within five (5) calendar days of bid opening.
 - 1.3.3 No direct contact is allowed between Vendor and other City/County staff throughout the bid process.
 - 1.3.3.1 Failure to comply with this directive may result in Vendor bid being rejected.

2. ORDERS AND DELIVERY

- 2.1 Orders will be placed by all Departments throughout the City/County via phone, e-mail or fax.
 - 2.1.1 All contact information as well as your preferred method of order placement **MUST** be provided in the attributes portion of the response.
- 2.2 Delivery will be F.O.B. destination which will be given at the time of order by various City and County Departments.
 - 2.1.1 A standard delivery time must be included in the attributes portion of the response and may be used to determine the best over-all value to the Entities.

3. ESTIMATED QUANTITIES

- 3.1 The quantities set forth in the specification document are approximate and represent the estimated requirements of the Owners for the contract period.
- 3.2 Items listed may or may not be inclusive of Owners requirements for this category.
- 3.3 Category items not listed, but distributed by bidder are to be referred to as kindred items.
 - 3.3.1 An attribute will be listed to establish a percent off of the Vendors most current list price.
- 3.4 The unit prices and the extended total prices shall be used only as a basis for the evaluation of bids.
 - 3.4.1 The actual quantity of materials necessary may be more or less than the estimates listed in the specification document, but the Owners shall be neither obligated nor limited to any specified amount.

4. CONTRACT AWARD

- 4.1 If multiple awards are made, the Purchasing Department will issue a Contract to all successful bidders.
 - 4.1.1 Such contract will incorporate the Owners's specifications, and may incorporate the bidder's specifications.
- 4.2 Orders for materials will be made as needed by the various Owners' Departments.

5. QUARTERLY REPORT

- 5.1 The contractor shall provide to the Purchasing Agent a quarterly report, showing all purchases made under the terms and conditions of the contract.
- 5.2 Such quarterly report shall itemize the following information:
 - 5.2.1 Each ordering Agency and Department.
 - 5.2.2 Items and quantities purchased by Agency and Department.
 - 5.3.3 Total dollar amount of purchases by Agency and Department.

6. **TERMINATION OF CONTRACT**

- 6.1 This contract may also be terminated by either party upon thirty (30) days prior notice in writing to the other party.
 - 6.1.1 The Owner may terminate this contract immediately, under breach of contract, if the Contractor fails to perform in accordance with the terms and conditions.
 - 6.1.2 In the event of any termination of contract by the Contractor, the Owner may purchase such supplies and/or services similar to those so terminated, and for the duration of the contract period the Contractor will be liable for all costs in excess of the established contract pricing.

7. **GENERAL REQUIREMENTS**

- 7.1 All blanks shall be new, die cut (or equal), aluminum meeting A.S.T.M. Specification B209, Alloy 5052-H38 of the gauge specified in the tabulation of the gauge specified in the tabulation of quantities, sizes and shapes.
- 7.2 All blanks of a given size and shape must be exactly the same size and shape with all angles and corner radius uniform and exactly as specified.
- 7.3 The edges of all blanks shall be smooth and free of sharp edges, rough edges or burrs which would harm the hands of a person handling the blanks.
- 7.4 All blanks must be flat and free of warp making them difficult to apply a sign face.
- 7.5 Both faces of blanks shall be treated with an Alodine 1200 process or other equivalent protective process with the chemical conversion coating light in colored, tight and free from powdery residues.

8. **DESIGN**

- 8.1 All sign blanks shall conform to the MUTCD FHWA Standard Highways Sign Manual, 2002 Edition, Blank Standards in shape, size, corner radius, hole location, and have 3/8" holes.
- 8.2 Sign blanks designated as City Specifications shall conform to the following details in shape, size, corner radius, and hole location unless noted different by the City.
 - 8.2.1 Street name sign blanks, .080 gauge; width varies; height 6" and 9" per attached drawing, called City Sign Spec Drawings.
 - 8.2.2 Dual sign plate, .063 gauge, 18 x 18, Standard Radius Punched per City Sign Spec Drawing.

9. **PACKING AND SHIPPING**

- 9.1 Sign blanks shall be grouped by each different shape, size, thickness, and shall be wrapped or boxed in packages of 10 or 25 blanks per package or shall be stacked with each count of 10 or 25 blanks offset a minimum of 1/4" within the stack to allow easy inventory of quantity.
 - 9.1.1 The City's sign blanks will be delivered to:
City of Lincoln Traffic Engineering
901 West Bond Street
Suite 125
Lincoln, Nebraska 68521
E-Mail: mlammli@lincoln.ne.gov
Please e-mail tracking information upon shipping
 - 9.1.2 The delivery location for Lancaster County:
Lancaster County Maintenance Shop
444 Cherrycreek Road
Building C
Lincoln NE 68528
E-Mail: rbohaty@lancaster.ne.gov
Please e-mail tracking information upon shipping
- 9.3 Sign blanks shall be packed on strong skids in such a manner as to facilitate unloading by a hand pallet jack with 4" high forks.
 - 9.3.1 All blanks shall be secured to the skid with steel banding.

9.4 Sign blanks shall be covered as necessary to protect from weather.

INSTRUCTIONS TO BIDDERS

City of Lincoln, Nebraska, County of Lancaster

E-Bid

1. BIDDING PROCEDURE

- 1.1 Sealed bid, formal and informal, subject to Instructions and General Conditions and any special conditions set forth herein, will be received in the office of the Purchasing Division, 440 So. 8th St., Lincoln, NE 68508, until the bid closing date and time indicated for furnishing the City of Lincoln and Lancaster County, hereafter referred to as "Owners" the materials, supplies, equipment or services shown in the electronic bid request.
- 1.2 Bidders shall use the electronic bid system for submitting bids and must complete all required fields. If you do not care to bid, please respond to the bid request and note your reason.
- 1.3 Identify the item you will furnish by brand or manufacturer's name and catalog numbers. Also furnish specifications and descriptive literature if not bidding the specific manufacturer or model as listed in the specifications.
- 1.4 Any person submitting a bid for a firm, corporation, or other organization must show evidence of his authority so to bind such firm, corporation, or organization.
- 1.5 Bids received after the time and date established for receiving bids will be rejected.
- 1.6 The Bidders and public are invited, but not required, to attend the formal opening of bids. At the opening, prices will be displayed electronically and/or read aloud to the public. The pricing is also available for immediate viewing on-line. No decisions related to an award of a contract or purchase order will be made at the opening.
- 1.7 If bidding on a construction contract, the City's Standard Specifications for Municipal Construction 2011 shall apply.
 - 1.7.1 Bidders may obtain this document from the City's Design Engineering Division of the Public Works & Utilities Department for a small fee.
 - 1.7.2 Said document can be reviewed at Design Engineering or the office of the Purchasing Division.
 - 1.7.3 Said document is available on the web site.
<http://www.lincoln.ne.gov/city/pworks/engine/dconst/standard/stdndspec/index.htm>

2. BID SECURITY

- 2.1 Bid security, as a guarantee of good faith, in the form of a certified check, cashier's check, or bidder's bond, may be required to be submitted with this bid document, as indicated on the bid.
 - 2.1.1 Bid security, if required, shall be in the amount specified on the bid. The bid security must be scanned and attached to the "Response Attachments" section of your response or it can be faxed to the Purchasing Office at 402-441-6513. The original bid security should then be sent or delivered to the office of the Purchasing Division, 440 S. 8th St., Ste. 200, Lincoln, NE 68508 to be received within three (3) days of bid closing.
 - 2.1.2 If bid security is not received in the Office of the Purchasing Division as stated above, the vendor may be determined to be non-responsive.
- 2.2 If alternates are submitted, only one bid security will be required, provided the bid security is based on the amount of the highest gross bid.
- 2.3 Such bid security will be returned to the unsuccessful Bidders when the award of bid is made.
- 2.4 Bid security will be returned to the successful Bidder(s) as follows:
 - 2.4.1 For single order bids with specified quantities: upon the delivery of all equipment or merchandise, and upon final acceptance by the Owners.
 - 2.4.2 For all other contracts: upon approval by the Owners of the executed contract and bonds.
- 2.5 Owners shall have the right to retain the bid security of Bidders to whom an award is being considered until either:
 - 2.5.1 A contract has been executed and bonds have been furnished.
 - 2.5.2 The specified time has elapsed so that the bids may be withdrawn.
 - 2.5.3 All bids have been rejected.
- 2.6 Bid security will be forfeited to the Owners as full liquidated damages, but not as a penalty, for any of the following reasons, as pertains to this specification document:
 - 2.6.1 If the Bidder fails or refuses to enter into a contract on forms provided by the Owners, and/or if the Bidder fails to provide sufficient bonds or insurance within the time period as established in this specification document.

3. BIDDER'S REPRESENTATION

- 3.1 Each Bidder by electronic signature and submitting a bid, represents that the Bidder has read and understands the specification documents, and the bid has been made in accordance therewith.
- 3.2 Each Bidder for services further represents that the Bidder has examined and is familiar with the local conditions under which the work is to be done and has correlated the observations with the requirements of the bid documents.

4. CLARIFICATION OF SPECIFICATION DOCUMENTS

- 4.1 Bidders shall promptly notify the Purchasing Agent of any ambiguity, inconsistency or error which they may discover upon examination of the specification documents.
- 4.2 Bidders desiring clarification or interpretation of the specification documents for formal bids shall make a written request which must reach the Purchasing Agent at least five (5) calendar days prior to the date and time for receipt of formal bids.
- 4.3 Changes made to the specification documents will be issued electronically. All vendors registered for that bid will be notified of the addendum. Subsequent Bidders will only receive the bid with the addendum included.
- 4.4 Oral interpretations or changes to the bidding documents made in any manner other than written form will not be binding on the Owners; and Bidders shall not rely upon such interpretations or changes.

5. ADDENDA

- 5.1 Addenda are instruments issued by the Owners prior to the date for receipt of bids which modify or interpret the specification document by addition, deletion, clarification or correction.
- 5.2 Addenda notification will be made available to all registered vendors immediately via e-mail for inspection on-line.
- 5.3 No formal bid addendums will be issued later than forty-eight (48) hours prior to the date and time for receipt of formal bids, except an addendum withdrawing the invitation to bid, or an addendum which includes postponement of the bid.

6. INDEPENDENT PRICE DETERMINATION

- 6.1 By signing and submitting this bid, the Bidder certifies that the prices in this bid have been arrived at independently, without consultation, communication or agreement, for the purpose of restricting competition, as to any matter relating to such prices with any other Bidder or with any competitor; unless otherwise required by law, the prices which have been quoted in this bid have not been knowingly disclosed by the Bidder prior to bid opening directly or indirectly to any other Bidder or to any competitor; no attempt has been made, or will be made, by the Bidder to induce any person or firm to submit, or not to submit, a bid for the purpose of restricting competition.

7. ANTI-LOBBYING PROVISION

- 7.1 During the period between the bid advertisement date and the contract award, Bidders, including their agents and representatives, shall not lobby or promote their bid with any member of the City or County staff or officers except in the course of Owner sponsored inquiries, briefings, interviews, or presentations, unless requested by the Owners.

8. BRAND NAMES

- 8.1 Wherever in the specifications or bid that brand names, manufacturer, trade name, or catalog numbers are specified, it is for the purpose of establishing a grade or quality of material only; and the term "or equal" is deemed to follow.
- 8.2 It is the Bidder's responsibility to identify any alternate items offered in the bid, and prove to the satisfaction of the Owners that said item is equal to, or better than, the product specified.
- 8.3 Bids for alternate items shall be stated in the appropriate space on the e-bid form, or if the proposal form does not contain blanks for alternates, Bidder MUST attach to its bid document on Company letterhead a statement identifying the manufacturer and brand name of each proposed alternate, plus a complete description of the alternate items including illustrations, performance test data and any other information necessary for an evaluation.
- 8.4 The Bidder must indicate any variances by item number from the specification document no matter how slight.
- 8.5 If variations are not stated in the bid, it will be assumed that the item being bid fully complies with the Owners' bidding documents.

9. DEMONSTRATIONS/SAMPLES

- 9.1 Bidders shall demonstrate the exact item(s) proposed within seven (7) calendar days from receipt of such request from the Owners.
- 9.2 Such demonstration can be at the Owners delivery location or a surrounding community.
- 9.3 If items are small and malleable, the Bidder is proposing an alternate product, the Bidder shall supply a sample of the exact item. Samples will be returned at Bidder's expense after receipt by the Owners of acceptable goods. The Bidder must indicate how samples are to be returned.

10. DELIVERY (Non-Construction)

- 10.1 Each Bidder shall state on the bid the date upon which it can make delivery of all equipment or merchandise.
- 10.2 The Owners reserve the right to cancel orders, or any part thereof, without obligation, if delivery is not made within the time(s) specified on the bid.
- 10.3 All bids shall be based upon **inside** delivery of the equipment/ merchandise F.O.B. the Owners at the location specified by the Owners, with all transportation charges paid.
- 10.4 At the time of delivery, a designated Owner employee will sign the invoice/packing slip. The signature will only indicate that the order has been received and the items actually delivered agree with the delivery invoice. This signature does not indicate all items met specifications, were received in good condition and/or that there is not possible hidden damage or shortages.

11. WARRANTIES, GUARANTEES AND MAINTENANCE

- 11.1 Copies of the following documents, if requested, shall accompany the bid proposal for all items being bid::
- 11.1.1 Manufacturer's warranties and/or guarantees.
 - 11.1.2 Bidder's maintenance policies and associated costs.
- 11.2 As a minimum requirement of the Owners, the Bidder will guarantee in writing that any defective components discovered within a one (1) year period after the date of acceptance shall be replaced at no expense to the Owners. Replacement parts of defective components shall be shipped at no cost to the Owners. Shipping costs for defective parts required to be returned to the Bidder shall be paid by the Bidder.

12. ACCEPTANCE OF MATERIAL

- 12.1 All components used in the manufacture or construction of materials, supplies and equipment, and all finished materials, shall be new, the latest make/model, of the best quality, and the highest grade workmanship.
- 12.2 Material delivered under this proposal shall remain the property of the Bidder until:
- 12.2.1 A physical inspection and actual usage of the material is made and found to be acceptable to the Owners; and
 - 12.2.2 Material is determined to be in full compliance with the bidding documents and accepted proposal.
- 12.3 In the event the delivered material is found to be defective or does not conform to the specification documents and accepted proposal, the Owners reserves the right to cancel the order upon written notice to the Bidder and return materials to the Bidder at Bidder's expense.
- 12.4 Awarded Bidder shall be required to furnish title to the material, free and clear of all liens and encumbrances, issued in the name of the Owner, as required by the specification documents or purchase orders.
- 12.5 Awarded Bidder's advertising decals, stickers or other signs shall not be affixed to equipment. Vehicle mud flaps shall be installed blank side out with no advertisements. Manufacturer's standard production forgings, stampings, nameplates and logos are acceptable.

13. BID EVALUATION AND AWARD

- 13.1 The electronic signature shall be considered an offer on the part of the Bidder. Such offer shall be deemed accepted upon issuance by the Owners of purchase orders, contract award notifications, or other contract documents appropriate to the work.
- 13.2 No bid shall be modified or withdrawn for a period of ninety (90) calendar days after the time and date established for receiving bids, and each Bidder so agrees in submitting the bid.
- 13.3 In case of a discrepancy between the unit prices and their extensions, the unit prices shall govern.
- 13.4 The bid will be awarded to the lowest responsible, responsive Bidder whose bid will be most advantageous to the Owners, and as the Owners deem will best serve the requirements and interests of the Owners.
- 13.5 The Owners reserves the right to accept or reject any or all bids; to request rebids; to award bids item-by-item, with or without alternates, by groups, or "lump sum"; to waive minor irregularities in bids; such as shall best serve the requirements and interests of the Owners.
- 13.6 In order to determine if the Bidder has the experience, qualifications, resources and necessary attributes to provide the quality workmanship, materials and management required by the plans and specifications, the Bidder may be required to complete and submit additional information as deemed necessary by the Owners. Failure to provide the information requested to make this determination may be grounds for a declaration of non-responsive with respect to the Bidder.
- 13.7 The Owners reserves the right to reject irregular bids that contain unauthorized additions, conditions, alternate bids, or irregularities that make the Bid Proposal incomplete, indefinite or ambiguous.
- 13.8 Any governmental agency may piggyback on any contract entered into from this bid.

14. INDEMNIFICATION

- 14.1 The Bidder shall indemnify and hold harmless the Owners from and against all losses, claims, damages, and expenses, including, attorney's fees arising out of or resulting from the performance of the contract that results in bodily injury, sickness, disease, death, or to injury to or destruction of tangible property, including the loss of use resulting therefrom and is caused in whole or in part by the Bidder, any subcontractor, any directly or indirectly employed by any of them or anyone for whose acts any of them may be liable. This section will not require the Bidder to indemnify or hold harmless the Owners for any losses, claims damages, and expenses arising out of or resulting from the sole negligence of the Owners.
- 14.2 In any and all claims against the Owners or any of its members, officers or employees by an employee of the Bidder, any subcontractor, anyone directly or indirectly employed by any of them or by anyone for whose acts made by any of them may be liable, the indemnification obligation under paragraph 14.1 shall not be limited in any way by any limitation of the amount or type of damages, compensation or benefits payable by or for the Bidder or any subcontractor under worker's compensation acts, disability benefit acts or other employee benefit acts.

15. TERMS OF PAYMENT

- 15.1 Unless stated otherwise, the Owners will begin processing payment within thirty (30) calendar days after all labor has been performed and all equipment or other merchandise has been delivered, and all such labor and equipment and other materials have met all contract specifications.

16. LAWS

- 16.1 The laws of the State of Nebraska shall govern the rights, obligations, and remedies of the parties under this proposal and any contract reached as a result of this process.
- 16.2 Bidder agrees to abide by all applicable local, state and federal laws and regulations concerning the handling and disclosure of private and confidential information concerning individuals and corporations as to inventions, copyrights, patents and patent rights.

17. EQUIPMENT TAX ASSESSMENT

- 17.1 Any bid for public improvement shall comply with Nebraska Revised Statutes Section 77-1323 and 77-1324. Indicating; every person, partnership, limited liability company, association or corporation furnishing labor or material in the repair, alteration, improvement, erection, or construction of any public improvement shall sign a certified statement which will accompany the contract. The certified statement shall state that all equipment to be used on the project, except that acquired since the assessment date, has been assessed for taxation for the current year, giving the county where assessed.

18. AFFIRMATIVE ACTION

- 18.1 The City of Lincoln-Lancaster County provides equal opportunity for all Bidders and encourages minority businesses, women's businesses and locally owned business enterprises to participate in our bidding process.

19. INSURANCE

- 19.1 All Bidders shall take special notice of the insurance provisions required for all City/County contracts (see *Insurance Requirements*).

20. EXECUTION OF AGREEMENT

- 20.1 Depending on the type of service or commodity provided, one of the following methods will be employed. The method applicable to this contract will be checked below:
- a. **PURCHASE ORDER**, unless otherwise noted.
 - 1. The contract shall consist of a City of Lincoln and Lancaster County Purchase Order.
 - 2. A copy of the Bidder's bid response (or referenced bid number) attached and that the same, in all particulars, becomes the contract between the parties hereto: that both parties thereby accept and agree to the terms and conditions of said bid documents.
 - b. **CONTRACT**, unless otherwise noted.
 - 1. City and County will furnish copies of the Contract to the successful Bidder who shall prepare attachments as required. Insurance as evidenced by a Certificate of Insurance (as required), surety bonds properly executed (as required), and Contract signed with the dated.
 - 2. The prepared documents shall be returned to the Purchasing Office within 10 days (unless otherwise noted).
 - 3. The City and County will sign and date the Contract.
 - 4. Upon approval and signature, the City and County, will return one copy to the successful Bidder.

21. TAXES AND TAX EXEMPTION CERTIFICATE

- 21.1 The Owners are generally exempt from any taxes imposed by the state or federal government. A Tax Exemption Certificate will be provided as applicable.

22. CITY AUDIT ADVISORY BOARD

- 22.1 All parties of any City agreement shall be subject to audit pursuant to Chapter 4.66 of the Lincoln Municipal Code and shall make available to a contract auditor, as defined therein, copies of all financial and performance related records and materials germane to the contract/order, as allowed by law.
- 22.2 The Water Division of the City of Lincoln is taxable per Reg. 066.14A and no exemption certificate will be issued.

23. E-VERIFY

- 23.1 In accordance with Neb. Rev. Stat. 4-108 through 4-114, the contractor agrees to register with and use a federal immigration verification system, to determine the work eligibility status of new employees performing services within the state of Nebraska. A federal immigration verification system means the electronic verification of the work authorization program of the Illegal Immigration Reform and Immigrant Responsibility Act of 1996, 8 U.S.C. 1324 a, otherwise known as the E-Verify Program, or an equivalent federal program designated by the United States Department of Homeland Security or other federal agency authorized to verify the work eligibility status of a newly hired employee pursuant to the Immigration Reform and Control Act of 1986. The Contractor shall not discriminate against any employee or applicant for employment to be employed in the performance of this section pursuant to the requirements of state law and 8 U.S.C.A 1324b. The contractor shall require any subcontractor to comply with the provisions of this section. For information on the E-Verify Program, go to www.uscis.gov/everify.

**Advertise 2 times
Friday, August 25, 2017
Friday, September 1, 2017**

**City of Lincoln/Lancaster County
Purchasing Division
NOTICE TO BIDDERS**

Sealed bids will be received by the Purchasing Agent of the City of Lincoln/Lancaster County, Nebraska
BY ELECTRONIC BID PROCESS until: **12:00 pm, Friday, September 8, 2017** for providing the following:

**Annual Supply
Aluminum Sign Blanks
Bid No. 17-240**

Bidders must be registered on the City/County's E-Bid site in order to respond to the above Bid. To register go to: lincoln.ne.gov (type: e-bid - in search box, then click "Supplier Registration").

Questions concerning this bid process may be directed to City/County Purchasing at (402) 441-8103 or purchasing@lincoln.ne.gov