

Received Date

**LANCASTER COUNTY
555 SOUTH 10TH STREET
LINCOLN, NE 68508**

Utility Permit No.

Application Date

**Application to Construct
Utilities On County property**

Project or WO No.

Contract No.

County Rep.

Application is hereby made to LANCASTER COUNTY by:

Name:

Company Name:

Phone:

Address:

E-Mail:

To construct a utility or utilities on County right-of-way as follows:

LEGAL DESCRIPTION:

UTILITY TO BE CONSTRUCTED

TYPE

DESCRIPTION

ANNOTATION

Other

PROPOSED UTILITY INSTALLATION

METHOD

SIZE/WIDTH

DESCRIPTION

DEPTH

DESCRIPTION

Other

NAME AND ADDRESS OF CONTRACTOR(S) PERFORMING THE WORK (if Applicable):

UTILITY PERMIT REQUIREMENTS

NOTE – If Engineer plan sheet project notes conflict with Lancaster County’s utility permit application requirements and the special utility permit requirements, the utility permit application requirements and special utility permit requirements shall govern. **See Page 6 for additional requirements upon permit approval.**

1. Unless agreed to in writing in advance by the owner, the depth of installed facilities shall be at a minimum as follows:
 - A. For utility installation parallel to the roadway, the minimum depth of burial will be 42” (48” in road ditches) measured from the ground surface to the top of the utility, except as noted in “C” below.
 - B. For utility installation transverse to the roadway the minimum depth of burial will be 48” measured from the ground surface to the top of the utility, except as noted in “C” below.
 - C. The minimum depth of burial beneath drainage structures, waterways, creek channels, or culverts within 5’ of the utility route will be 72”, measured from the flow line of the drainage structure, waterway, or creek channel (whichever is lower), to the top of the utility.
 - D. No utility will be buried directly above a drainage structure, **regardless of the burial depth.**
 - E. All crossings with existing utilities will be separated by a minimum of 24”, both horizontally and vertically.
 - F. All paved road and paved driveway crossings will be dry-bored.
 - G. All areas disturbed by construction will be restored to their pre-construction condition. This includes: all open-cut crossings to be backfilled with material excavated from trench; no sand or crushed rock backfill will be allowed; and compaction of backfills to a density equal to or greater than the surrounding soil in and around trenches, bore pits, pull boxes, and other utility appurtenances. It also includes replacing roadway and driveway surfacing lost or damaged by construction, and re-seeding of all areas disturbed by the work.
 - H. Trees within the right-of-way will be preserved by the contractor when possible. All trees, bushes, brush, debris piles, resulting from clearing or grubbing operations will become the property of the contractor and will be removed from county property at the contractor’s expense.
2. The contractor performing the work shall have onsite a copy of approved utility permit allowing permitted work to be done within County Road Right-of-Way.
3. The utility owner or his representative will mark all existing Lancaster County drainage structures along the proposed utility installation route 24 hours prior to construction at a culvert site. All structures will be marked in a manner so as to allow the Utility’s Contractor to identify all “Bore” locations.
4. The contractor will notify Lancaster County Maintenance Superintendent Bob Jacobs at 402-441-7797, within 48 hours, prior to commencing construction on county right-of way.
5. Contractor performing the work to submit insurance certificate naming Lancaster County as additional insured prior to any activities in the right-of-way. Contractor shall also provide Lancaster County a 30 day notice of cancellation, non-renewal or any material reduction of insurance coverage.
6. The applicant, or his contractor, shall contact the local utility companies and request location of any buried utilities. Damage to any utilities, either on County right-of-way or adjacent to County right-of-way, shall be repaired at the expense of the applicant or his contractor.

7. Future road construction work could necessitate relocation of utilities. Those utility relocation costs shall be borne by the utility owner.
8. All trenches shall be backfilled the same day trench was excavated except for the portion where the work is to be continued the next day. The portion left open for work continuation shall be protected by barricades with flashing lights at night. No open trenches in the roadway will be allowed overnight. (Except when such road is closed for construction or except with prior conditional approval to be noted on page #6)
9. Roads may be closed for a maximum of 12 hours, with prior review and approval from this office. (See #11 for signage layout)
10. Road closures longer than 12 hours will require prior review and shall include an approved detour plan. (See #11 for signage layout)
11. Three Type III barricades w/Type A flashing lights shall be placed on each side of construction site. "Road Closed" {R 1 1-2} signs shall be mounted on the middle barricade on each side of the construction site. At the nearest intersection each way from crossing, a "Road Closed _____ Miles ahead -- Local Traffic Only" (R11-3) sign shall be placed.
12. All barricading, flagmen, warning signs, etc. shall conform to the current **Manual on Uniform Traffic Control Devices.**
13. No equipment shall be left unattended on public right-of-way. No trenches shall be left open after working hours. No equipment shall block traffic control devices. If necessary, flagmen shall be required.
14. All pipe and encasements to conform to State Highway Standards.
15. **Notification of proposed utility work to adjacent landowners shall be the responsibility of the Utility Company and or their Agents.**
16. *****Utility Company and or their Agents shall be responsible to notify the Lancaster County Engineering Department upon completion of permitted utility work.*****

TYPICAL CROSS SECTION OF ROAD CROSSING
(Proposed Drawing by Applicant)

See Attached Drawing
UR-D-0789

I (We) agree to construct the _____ in accordance with the permit requirements and
(utility)
the provisions included as a part of this permit.

COMPANY:

DATE:

SIGNED BY:

EXECUTION BY LANCASTER COUNTY

The above application is hereby approved subject to the requirements and provisions of the permit.

APPROVED and dated this _____ day of _____ by the Lancaster County
Board of Commissioners.

LANCASTER COUNTY BOARD OF COMMISSIONERS

Chairperson

APPROVED as to form

this _____ day of _____

Deputy County Attorney

REVIEWED this _____ day of _____, _____

Lancaster County Engineering Representative

I (We) agree to construct the _____ (utility) _____ in accordance with the permit requirements and the provisions included as a part of this permit.

COMPANY:

DATE:

SIGNED BY:

EXECUTION BY LANCASTER COUNTY

The above application is hereby approved subject to the requirements and provisions of the permit.

Date

Signed By:

Lancaster County Representative

This Page Intentionally Left Blank

(TO BE FILLED IN BY COUNTY PERSONNEL)

Encasement Requirements:

Barricade, Signing and Flagging Requirements:

Methods of Installation:

Minimum Cover Provided in Road Ditches:

Other Requirements:

Additional Comments:

**INSURANCE CLAUSE
FOR LANCASTER COUNTY ENGINEER UTILITY PERMITS**

Insurance; Coverage Information

The contractor shall, prior to beginning work, provide proof of insurance coverage in a form satisfactory to the County, which shall not withhold approval unreasonably. The coverages and minimum levels required by this contract are set forth below and shall be in effect for all times that work is being done pursuant to this Contract. No work on the Project or pursuant to this Contract shall begin until all insurance obligations herein are met to the satisfaction of the County, which shall not unreasonably withhold approval. Self-insurance shall not be permitted unless consent is given by the County prior to execution of the Agreement and may require submission of financial information for analysis. Deductible levels shall be provided in writing from the Contractor's insurer and will be no more than \$25,000.00 per occurrence. Said insurance shall be written on an **OCCURRENCE** basis, and shall be **PRIMARY, with any insurance coverage maintained by the County being secondary or excess.**

Certificates

The Contractor shall provide certificates of insurance and endorsements evidencing compliance with these requirements. The Contractor shall provide a Certificate of Insurance demonstrating the coverage required herein and the necessary endorsements and waivers described herein and below before being permitted to begin the work or project. All certificates, endorsements and endorsement forms (where required) must be acceptable to the County Attorney. Certificates shall include an endorsement to provide for at least thirty (30) days' firm written notice in the event of cancellation. During the term of the Agreement and during the period of any required continuing coverages, the Contractor shall provide, prior to expiration of the policies, certificates and endorsement forms evidencing renewal insurance coverages. The parties agree that the failure of County to object to the form of a certificate and/or additional insured endorsement or endorsement forms provided shall not constitute a waiver of this requirement.

1. Commercial General Liability

The Contractor shall provide proof of Commercial General Liability Insurance with a minimum limit of not less than \$1,000,000.00 each occurrence and \$2,000,000.00 aggregate. These minimum limits can be met by primary and umbrella liability policies. Coverage shall include: Premises-Operations, Products/ Completed Operations, Contractual, Broad Form Property Damage, and Personal Injury. Such coverage shall be endorsed for the general aggregate to be on a **PER PROJECT** basis, and the contractor shall provide an additional insured endorsement acceptable to the County. The required insurance must include coverage for all projects and operations of Contractor or similar language that meets the approval of the County, which approval shall not be unreasonably withheld.

1.1 Additional Insured (Requires an Endorsement Form)

An Additional Insured Endorsement Form showing the County as additional Insured.

1.2 Automobile Liability

The Contractor shall provide proof of Automobile Liability coverage, which shall include: Owned, Hired and Non-Owned. Bodily Injury and Property Damage Combined Single Limit shall be at least \$1,000,000 Per Accident.

1.3 Intentionally Omitted

1.4. Workers' Compensation; Employers' Liability

The Contractor shall provide proof of workers' compensation insurance of not less than minimum statutory requirements under the laws of the State of Nebraska and any other applicable State. Employers' Liability coverage with limits of not less than \$500,000.00 each accident or injury shall be included. The Contractor shall provide the County with an endorsement for waiver of subrogation. The contractor shall also be responsible for ensuring that all subcontractors have workers' compensation insurance for their employees before and during the time any work is done pursuant to this Contract.

1.5 Intentionally Omitted

1.5.1 Intentionally Omitted

1.6 Intentionally Omitted

1.7 Intentionally Omitted

1.8 Railroad Contractual Liability Insurance (Required only if appropriate)

If work is to be performed within 50 feet of any railroad property and affecting any railroad bridge or trestle, tracks, road beds, tunnel, underpass or railroad crossing, the Contractor must provide an endorsement (ISO® form CG24170193 or newer) that removes or deletes any exception for such work in the Contractor's commercial general liability policy. Any endorsement not described herein shall be subject to the approval of the County Attorney.

1.8.1 Railroad Protective Liability (Required only if appropriate)

If work is to be performed within 50 feet of any railroad property and affecting any railroad bridge or trestle, tracks, road beds, tunnel, underpass or crossing or otherwise required by the Special Provisions or applicable requirements of an affected railroad, the Contractor shall provide Railroad Protective Liability Insurance naming the affected railroad/s as insured with minimum limits for bodily injury and property damage of \$2,000,000 per occurrence, \$6,000,000 aggregate, or such other limits as required in the Special Provisions or by the affected railroad. The original of the policy shall be furnished to the railroad and a certified copy of the same furnished to the County Purchasing Department prior to any related construction or entry upon railroad premises by the Contractor or for work related to the Contract.

1.9 Intentionally Omitted

2. Risk of Loss

Except to the extent covered by the builder's risk insurance, the Contractor shall have the sole responsibility for the proper storage and protection of, and assumes all risk of loss of, any Subcontractor's Work and tools, materials, equipment, supplies, facilities, offices and other property at or off the Project site. The Contractor shall be solely responsible for ensuring each subcontractor shall take every reasonable precaution in the protection of all structures, streets, sidewalks, materials and work of other subcontractors. Contractor shall protect its Work from damage by the elements or by other trades working in the area.

3. Umbrella or Excess Liability

The Contractor may use an Umbrella, Excess Liability, or similar coverage to supplement the primary insurance stated above in order to meet or exceed the minimum coverage levels required by this Contract.

4. Minimum Scope of Insurance

All Liability Insurance policies shall be written on an "Occurrence" basis only. All insurance coverage are to be placed with insurers authorized to do business in the State of Nebraska and must be placed with an insurer that has an A.M. Best's Rating of no less than A:VII unless specific approval has been granted otherwise.

5. Indemnification

To the fullest extent permitted by law the Contractor shall indemnify, defend, and hold harmless the County, its elected officials, officers, employees, agents, consultants, and employees of any of them from and against claims, damages, losses and expenses, including but not limited to attorney fees, arising out of or resulting from performance of the Work, provided that such claim, damage, loss or expense is attributable to bodily injury, sickness, disease or death, or to injury to or destruction of tangible or intangible property, including the Work itself, but only to the extent caused by the negligent, wrongful, or intentional acts or omissions of the Contractor, a subcontractor, anyone directly or indirectly employed by them or anyone for whose acts they may be liable, regardless of whether or not such claim, damage, loss or expense is caused in part by the negligence of a party indemnified hereunder. In the event the claim, damage, loss or expense is caused in part by the negligence of a party indemnified hereunder, the indemnification by the Contractor shall be prorated based on the extent of the liability of the party indemnified hereunder. Such obligation shall not be construed to negate, abridge, or reduce obligations of indemnity which would otherwise exist as to a party or person described in this Section. Nothing herein shall be construed to be a waiver of sovereign immunity by the County.

6. Reservation of Rights

The County reserves the right to require a higher limit of insurance or additional coverages when the County determines that a higher limit or additional coverage is required to protect the County or the interests of the public. Such changes in limits or coverages shall be eligible for a change order or amendment to the Contract.

7. Sovereign Immunity

Nothing contained in this clause or other clauses of this Agreement/Contract shall be construed to waive the Sovereign Immunity of the County.

For questions regarding Insurance Requirements, please contact Risk Management.



1040 O Street, P.O. Box 80869
Lincoln, NE 68501-0869

September 26, 2017

Jim Shotkoski
Lancaster County Engineering Department
444 Cherrycreek Road, Building C
Lincoln, Nebraska 68528

Subject: Application to Install a Vacant Underground Plastic Conduit

Dear Mr. Shotkoski:

Attached is an application to install a vacant underground plastic conduit in the area as described as follows:

1. Along the north side of paved Pioneers Blvd, starting from 985' east of the CL of South 1st St. east for approx. 850'.
 - a. (UR-D-0789, Sheet 4, Position 35-36)
2. Crossing paved Pioneers St, approx. 1,365' east of the CL of South 1st St.
 - a. (UR-D-0789, Sheet 4, Position 38)

Lincoln Electric System anticipates the need to have partial lane closures from October 1st to Dec. 31st, 2017.

After approval, please return the signed copy to:
Keaton Koehler
Lincoln Electric System
P.O. Box 80869
Lincoln, NE 68501

Sincerely,
Lincoln Electric System

Keaton Koehler
Transmission & Distribution Design

c: Emil Turek
Jeff Hlavac
Rod Heninger

DN #28S-12W W.O. #5026450

p: 402.475.4211
f: 402.475.0446
www.les.com

Lincoln Electric System



CERTIFICATE OF LIABILITY INSURANCE

DATE (MM/DD/YYYY)
4/5/2017

THIS CERTIFICATE IS ISSUED AS A MATTER OF INFORMATION ONLY AND CONFERS NO RIGHTS UPON THE CERTIFICATE HOLDER. THIS CERTIFICATE DOES NOT AFFIRMATIVELY OR NEGATIVELY AMEND, EXTEND OR ALTER THE COVERAGE AFFORDED BY THE POLICIES BELOW. THIS CERTIFICATE OF INSURANCE DOES NOT CONSTITUTE A CONTRACT BETWEEN THE ISSUING INSURER(S), AUTHORIZED REPRESENTATIVE OR PRODUCER, AND THE CERTIFICATE HOLDER.

IMPORTANT: If the certificate holder is an ADDITIONAL INSURED, the policy(ies) must be endorsed. If SUBROGATION IS WAIVED, subject to the terms and conditions of the policy, certain policies may require an endorsement. A statement on this certificate does not confer rights to the certificate holder in lieu of such endorsement(s).

PRODUCER UNICO Group, Inc. 1128 Lincoln Mall Suite 200 Lincoln NE 68508	CONTACT NAME: Megan Robison PHONE (A/C. No. Ext): (402)434-7200 E-MAIL ADDRESS: mrobison@unicogroup.com	FAX (A/C. No): (402)434-7272
	INSURER(S) AFFORDING COVERAGE	
INSURED MCO Ventures Inc., DBA: Nielsen Construction Company 10120 S. 148th Street, Suite 100 Omaha NE 68138-3921	INSURER A: United Fire & Casualty	
	INSURER B:	
	INSURER C:	
	INSURER D:	
	INSURER E:	
	INSURER F:	

COVERAGES CERTIFICATE NUMBER: 17-18 GL, AU, WC, UMB REVISION NUMBER:

THIS IS TO CERTIFY THAT THE POLICIES OF INSURANCE LISTED BELOW HAVE BEEN ISSUED TO THE INSURED NAMED ABOVE FOR THE POLICY PERIOD INDICATED. NOTWITHSTANDING ANY REQUIREMENT, TERM OR CONDITION OF ANY CONTRACT OR OTHER DOCUMENT WITH RESPECT TO WHICH THIS CERTIFICATE MAY BE ISSUED OR MAY PERTAIN, THE INSURANCE AFFORDED BY THE POLICIES DESCRIBED HEREIN IS SUBJECT TO ALL THE TERMS, EXCLUSIONS AND CONDITIONS OF SUCH POLICIES. LIMITS SHOWN MAY HAVE BEEN REDUCED BY PAID CLAIMS.

INSR LTR	TYPE OF INSURANCE	ADDL INSD	SUBR WVD	POLICY NUMBER	POLICY EFF (MM/DD/YYYY)	POLICY EXP (MM/DD/YYYY)	LIMITS
A	<input checked="" type="checkbox"/> COMMERCIAL GENERAL LIABILITY <input type="checkbox"/> CLAIMS-MADE <input checked="" type="checkbox"/> OCCUR GEN'L AGGREGATE LIMIT APPLIES PER: <input type="checkbox"/> POLICY <input checked="" type="checkbox"/> PROJECT <input type="checkbox"/> LOC <input type="checkbox"/> OTHER:			60460515	4/30/2017	4/30/2018	EACH OCCURRENCE \$ 1,000,000 DAMAGE TO RENTED PREMISES (Ea occurrence) \$ 100,000 MED EXP (Any one person) \$ 10,000 PERSONAL & ADV INJURY \$ 1,000,000 GENERAL AGGREGATE \$ 2,000,000 PRODUCTS - COMP/OP AGG \$ 2,000,000
A	<input checked="" type="checkbox"/> AUTOMOBILE LIABILITY <input type="checkbox"/> ANY AUTO <input type="checkbox"/> ALL OWNED AUTOS <input type="checkbox"/> SCHEDULED AUTOS <input type="checkbox"/> HIRED AUTOS <input type="checkbox"/> NON-OWNED AUTOS			60460515	4/30/2017	4/30/2018	COMBINED SINGLE LIMIT (Ea accident) \$ 1,000,000 BODILY INJURY (Per person) \$ BODILY INJURY (Per accident) \$ PROPERTY DAMAGE (Per accident) \$
A	<input checked="" type="checkbox"/> UMBRELLA LIAB <input checked="" type="checkbox"/> OCCUR <input type="checkbox"/> EXCESS LIAB <input type="checkbox"/> CLAIMS-MADE <input type="checkbox"/> DED <input checked="" type="checkbox"/> RETENTION \$ 10,000			60460515	4/30/2017	4/30/2018	EACH OCCURRENCE \$ 5,000,000 AGGREGATE \$ 5,000,000
A	<input checked="" type="checkbox"/> WORKERS COMPENSATION AND EMPLOYERS' LIABILITY ANY PROPRIETOR/PARTNER/EXECUTIVE OFFICER/MEMBER EXCLUDED? (Mandatory in NH) If yes, describe under DESCRIPTION OF OPERATIONS below		N/A	60460515	4/30/2017	4/30/2018	<input checked="" type="checkbox"/> PER STATUTE <input type="checkbox"/> OTHER E.L. EACH ACCIDENT \$ 500,000 E.L. DISEASE - EA EMPLOYEE \$ 500,000 E.L. DISEASE - POLICY LIMIT \$ 500,000

DESCRIPTION OF OPERATIONS / LOCATIONS / VEHICLES (ACORD 101, Additional Remarks Schedule, may be attached if more space is required)
The General Liability policy includes a blanket automatic additional insured endorsement that provides additional insured status on a primary and non-contributing basis including completed operations only when there is a written contract between the named insured and the certificate holder/entity(ies) that requires such status. The Workers Compensation policy includes a waiver of subrogation endorsement as required by written contract with the named insured prior to a loss.

CERTIFICATE HOLDER Lancaster County 555 South 10th Street Lincoln, NE 68508	CANCELLATION SHOULD ANY OF THE ABOVE DESCRIBED POLICIES BE CANCELLED BEFORE THE EXPIRATION DATE THEREOF, NOTICE WILL BE DELIVERED IN ACCORDANCE WITH THE POLICY PROVISIONS.
	AUTHORIZED REPRESENTATIVE Paul Hughes/MRO

POLICY NUMBER:

60460515

FORMS SUPPLEMENTAL DECLARATIONS

The following coverage form(s) govern coverage that is not limited to any specific state even though they are specifically listed in only one state in the declarations.

Other Forms

Applicable to the state of Nebraska

CG0001(04-13)	COMM GENERAL LIAB COVG FORM
CG2106(05-14)	EXCL-ACCESS/DISCLOSURE OF CONFIDENTIAL/PERSONAL
CG2147(12-07)	EMPLOYMENT-RELATED PRACTICES EXCL
CG2150(04-13)	AMENDMENT OF LIQUOR LIAB EXCLUSION
CG2155-(09-99)	TOTAL POLLUTION EXCL W/A HOSTILE FIRE EXCEPTION
CG2167(12-04)	FUNGI/BACTERIA EXCL
CG2170(01-15)	CAP ON LOSSES FROM CERTIFIED ACTS OF TERRORISM
CG2187(01-15)	CONDITIONAL EXCL OF TERRORISM
CG2196(03-05)	SILICA/SILICA-RELATED DUST EXCL
*CG7001(02-05)	COMMERCIAL GENERAL LIABILITY COVERAGE PART
*CG7004(02-05)	COMM GENERAL LIABILITY SUPPLEMENTAL DECLARATIONS
CG7125(02-12)	PROPERTY DAMAGE DEDUCTIBLE LIABILITY INSURANCE
CG7155(01-07)	ABUSE/MOLESTATION EXCL
CG7201(02-15)	EXTENDED ULTRA LIAB PLUS END
CG7224(09-14)	CONTRACTORS POLLUTION LEGAL LIAB INS END
IL-0021(07-02)	NUCLEAR ENERGY LIAB EXCL END
IL0017(11-98)	COMMON POLICY CONDITIONS
IL0259(09-07)	NE-CHGS CANCEL & NONRENEW
IL7009-(04-91)	AMENDATORY END PUNITIVE/EXEMPLARY DAMAGES EXCL
IL7068(01-10)	EXCL-LEAD-HAZARDOUS PROPERTIES
IL7069(01-10)	EXCL-UNDERGROUND STORAGE TANKS
IL7070(09-12)	ABSOLUTE ASBESTOS EXCL
IL7095(01-14)	INTERNET SECURITY & PRIVACY INS END
IL7105(10-14)	PRIMARY & NONCONTRIBUTORY-OTHER INSURANCE CONDITIO
ST1609(01-07)	NOTICE ABUSE/MOLESTATION EXCL
*ST1644(01-12)	POLICY WEBSITE STUFFER
ST1812(07-14)	IMPORTANT NOTICE-POLLUTION LEGAL LIAB
ST1813(10-15)	IMPORTANT NOTICE-INTERNET SECURITY & PRIVACY
*ST1882(06-16)	NOTICE-LOCATION & PREMISES CLARIFICATION

POLICY NUMBER:	60460515
-----------------------	----------

WORKERS COMPENSATION AND EMPLOYERS LIABILITY SUPPLEMENTAL DECLARATIONS

	Premium Basis Total Estimated Annual Remuneration	Rate Per \$100 of Remuneration	Estimated Annual Premium
<p>BLANKET WAIVER OF SUBROGATION - FORM WC000313</p> <p>WE HAVE THE RIGHT TO RECOVER OUR PAYMENTS FROM ANYONE LIABLE FOR AN INJURY COVERED BY THIS POLICY. WE WILL NOT ENFORCE OUR RIGHT AGAINST ANY PERSON OR ORGANIZATION WITH WHOM THE INSURED HAS AGREED, IN A WRITTEN CONTRACT OR AGREEMENT EXECUTED PRIOR TO THE ACCIDENT OR LOSS, THAT THIS RIGHT WILL BE WAIVED FOR WORK PERFORMED BY YOU FOR THAT PERSON OR ORGANIZATION.</p> <p>THIS AGREEMENT SHALL NOT OPERATE DIRECTLY OR INDIRECTLY TO BENEFIT ANY ONE NOT SPECIFICALLY IDENTIFIED IN A QUALIFYING CONTRACT OR AGREEMENT.</p>			



**EXTENDED ULTRA LIABILITY PLUS ENDORSEMENT
COMMERCIAL GENERAL LIABILITY EXTENSION ENDORSEMENT SUMMARY OF COVERAGES**

This is a summary of the various additional coverages and coverage modifications provided by this endorsement. No coverage is provided by this summary.

- * Extended Property Damage
- * Expanded Fire Legal Liability to include Explosion, Lightning and Sprinkler Leakage
- * Coverage for non-owned watercraft is extended to 51 feet in length
- * Property Damage - Borrowed Equipment
- * Property Damage Liability- Elevators
- * Coverage D - Voluntary Property Damage Coverage
\$5,000 Occurrence with a \$10,000 Aggregate
- * Coverage E - Care, Custody and Control Property Damage Coverage
\$25,000 Occurrence with a \$100,000 Aggregate - \$500 Deductible
- * Coverage F - Electronic Data Liability Coverage - \$50,000
- * Coverage G - Product Recall Expense
\$25,000 Each Recall Limit with a \$50,000 Aggregate - \$1,000 Deductible
- * Coverage H - Water Damage Legal Liability - \$25,000
- * Coverage I - Designated Operations Covered by a Consolidated (Wrap-Up) Insurance Program - Limited Coverage
- * Increase in Supplementary Payments: Bail Bonds to \$1,000
- * Increase in Supplementary Payments: Loss of Earnings to \$500
- * For newly formed or acquired organizations - extend the reporting requirement to 180 days
- * Broadened Named Insured
- * Automatic Additional Insured - Owners, Lessees or Contractors - Automatic Status When Required in Construction Agreement With You
- * Contractors Blanket Additional Insured - Limited Products - Completed Operations Coverage
- * Automatic Additional Insured - Vendors
- * Automatic Additional Insured - Lessor of Leased Equipment Automatic Status When Required in Lease Agreement With You
- * Automatic Additional Insured - Managers or Lessor of Premises
- * Additional Insured - Engineers, Architects or Surveyors Not Engaged by the Named Insured
- * Additional Insured - State or Governmental Agency or Subdivision or Political Subdivision - Permits or Authorizations
- * Additional Insured - Consolidated Insurance Program (Wrap-Up) Off-Premises Operations Only - Owners, Lessees or Contractors Automatic Status When Required in Construction Agreement With You
- * Additional Insured - Employee Injury to Another Employee
- * Automatically included - Aggregate Limits of Insurance (per location)
- * Automatically included - Aggregate Limits of Insurance (per project)
- * Knowledge of occurrence - Knowledge of an "occurrence", "claim or suit" by your agent, servant or employee shall not in itself constitute knowledge of the named insured unless an officer of the named insured has received such notice from the agent, servant or employee
- * Blanket Waiver of Subrogation
- * Liberalization Condition
- * Unintentional failure to disclose all hazards. If you unintentionally fail to disclose any hazards existing at the inception date of your policy, we will not deny coverage under this Coverage Form because of such failure. However, this provision does not affect our right to collect additional premium or exercise our right of cancellation or non-renewal.
- * "Insured Contract" redefined for Limited Railroad Contractual Liability
- * Mobile equipment to include snow removal, road maintenance and street cleaning equipment less than 1,000 lbs GVW
- * Bodily Injury Redefined

**REFER TO THE ACTUAL ENDORSEMENT FOLLOWING ON PAGES 2 THROUGH 13 FOR CHANGES AFFECTING
YOUR INSURANCE PROTECTION**



THIS ENDORSEMENT CHANGES THE POLICY. PLEASE READ IT CAREFULLY.

EXTENDED ULTRA LIABILITY PLUS ENDORSEMENT

This endorsement modifies insurance provided under the following:

COMMERCIAL GENERAL LIABILITY COVERAGE PART

SECTION I - COVERAGES

A. The following changes are made at **COVERAGE A - BODILY INJURY AND PROPERTY DAMAGE LIABILITY**

1. Extended Property Damage

At 2. **Exclusions** exclusion a. **Expected or Intended Injury** is replaced with the following:

"Bodily injury" or "property damage" expected or intended from the standpoint of the insured. This exclusion does not apply to "bodily injury" or "property damage" resulting from the use of reasonable force to protect persons or property.

2. Expanded Fire Legal Liability

At 2. **Exclusions** the last paragraph is deleted and replaced by the following:

Exclusions c. through n. do not apply to damage by fire, explosion, lightning, smoke resulting from such fire, explosion, or lightning or sprinkler leakage to premises while rented to you or temporarily occupied by you with permission of this owner. A separate limit of insurance applies to this coverage as described in **SECTION III - LIMITS OF INSURANCE**.

3. Non-Owned Watercraft

At 2. **Exclusions** exclusion g. **Aircraft, Auto Or Watercraft (2) (a)** is deleted and replaced by the following:

(a) Less than 51 feet long;

4. Property Damage – Borrowed Equipment

At 2. **Exclusions** the following is added to paragraph (4) of exclusion j. **Damage To Property**:

This exclusion does not apply to "property damage" to borrowed equipment while at a jobsite and while not being used to perform operations. The most we will pay for "property damage" to any one piece of borrowed equipment under this coverage is \$25,000 per occurrence. The insurance afforded under this provision is excess over any valid and collectible property insurance (including deductible) available to the insured, whether primary, excess, contingent or on any other basis.

5. Property Damage Liability – Elevators

At 2. **Exclusions** the following is added to paragraphs (3), (4) and (6) of exclusion j. **Damage To Property**:

This exclusion does not apply to "property damage" resulting from the use of elevators. However, any insurance provided for such "property damage" is excess over any valid and collectible property insurance (including deductible) available to the insured, whether primary, excess, contingent or on any other basis.

B. The following coverages are added

1. **COVERAGE D - VOLUNTARY PROPERTY DAMAGE COVERAGE**

"Property damage" to property of others caused by the insured:

a. While in your possession; or

b. Arising out of "your work".

Coverage applies at the request of the insured, whether or not the insured is legally obligated to pay.

For the purposes of this **Voluntary Property Damage Coverage** only:

Exclusion j. Damage to Property is deleted and replaced by the following:

j. Damage to Property

"Property damage" to:

- (1) Property held by the insured for servicing, repair, storage or sale at premises you own, rent, lease, operate or use;
- (2) Property transported by or damage caused by any "automobile", "watercraft" or "aircraft" you own, hire or lease;
- (3) Property you own, rent, lease, borrow or use.

The amount we will pay is limited as described below in **SECTION III - LIMITS OF INSURANCE**

For the purposes of this Voluntary Property Damage Coverage, our right and duty to defend ends when we have paid the Limit of Liability or the Aggregate Limit for this coverage.

2. COVERAGE E - CARE, CUSTODY AND CONTROL PROPERTY DAMAGE COVERAGE

For the purpose of this **Care, Custody and Control Property Damage Coverage** only:

a. Item (4) of **Exclusion j.** does not apply.

The amount we will pay is limited as described below in **SECTION III - LIMITS OF INSURANCE**

For the purposes of this Care, Custody and Control Property Damage Coverage, our right and duty to defend ends when we have paid the Limit of Liability or the Aggregate Limit for this coverage.

3. COVERAGE F - ELECTRONIC DATA LIABILITY COVERAGE

For the purposes of this **Electronic Data Liability Coverage** only:

a. **Exclusion p. of Coverage A – Bodily Injury And Property Damage Liability in Section I – Coverages** is replaced by the following:

2. Exclusions

This insurance does not apply to:

p. Electronic Data

Damages arising out of the loss of, loss of use of, damage to, corruption of, inability to access, or inability to manipulate "electronic data" that does not result from physical injury to tangible property.

However, this exclusion does not apply to liability for damages because of "bodily injury".

b. **"Property Damage"** means:

- (1) Physical injury to tangible property, including all resulting loss of use of that property. All such loss of use shall be deemed to occur at the time of the physical injury that caused it; or
- (2) Loss of use of tangible property that is not physically injured. All such loss of use shall be deemed to occur at the time of the "occurrence" that caused it; or
- (3) Loss of, loss of use of, damage to, corruption of, inability to access or inability to properly manipulate "electronic data", resulting from physical injury to tangible property. All such loss of "electronic data" shall be deemed to occur at the time of the "occurrence" that caused it.

For the purposes of this **Electronic Data Liability Coverage**, "electronic data" is not tangible property.

The amount we will pay is limited as described below in **SECTION III - LIMITS OF INSURANCE**

4. COVERAGE G - PRODUCT RECALL EXPENSE

a. Insuring Agreement

- (1) We will pay 90% of "product recall expense" you incur as a result of a "product recall" you initiate during the coverage period.
- (2) We will only pay for "product recall expense" arising out of "your products" which have been physically relinquished to others.

The amount we will pay is limited as described below in **SECTION III - LIMITS OF INSURANCE**



b. Exclusions

This insurance does not apply to "product recall expense" arising out of:

- (1) Any fact, circumstance or situation which existed at the inception date of the policy and which you were aware of, or could reasonably have foreseen that would have resulted in a "product recall".
- (2) Deterioration, decomposition or transformation of a chemical nature, except if caused by an error in the manufacture, design, processing, storage, or transportation of "your product".
- (3) The withdrawal of similar products or batches that are not defective, when a defect in another product or batch has been found.
- (4) Acts, errors or omissions of any of your employees, done with prior knowledge of any of your officers or directors.
- (5) Inherent vice, meaning a natural condition of property that causes it to deteriorate or become damaged.
- (6) "Bodily Injury" or "Property Damage".
- (7) Failure of "your product" to accomplish its intended purpose, including any breach of warranty of fitness, quality, efficacy or efficiency, whether written or implied.
- (8) Loss of reputation, customer faith or approval, or any costs incurred to regain customer market, or any other consequential damages.
- (9) Legal fees or expenses.
- (10) Damages claimed for any loss, cost or expense incurred by you or others for the loss of use of "your product".
- (11) "Product recall expense" arising from the "product recall" of any of "your products" for which coverage is excluded by endorsement.
- (12) Any "product recall" initiated due to the expiration of the designated shelf life of "your product".

5. COVERAGE H - WATER DAMAGE LEGAL LIABILITY

The Insurance provided under Coverage H (Section I) applies to "property damage" arising out of water damage to premises that are both rented to and occupied by you.

The Limit under this coverage shall not be in addition to the Damage To Premises Rented To You Limit.

The amount we will pay is limited as described below in **SECTION III - LIMITS OF INSURANCE**

6. COVERAGE I – DESIGNATED OPERATIONS COVERED BY A CONSOLIDATED (WRAP-UP) INSURANCE PROGRAM

The following exclusion is added to Paragraph 2. **Exclusions** of **SECTION I – COVERAGES COVERAGE A – BODILY INJURY AND PROPERTY DAMAGE LIABILITY**:

- r. This insurance does not apply to "bodily injury" or "property damage" arising out of either your ongoing operations or operations included within the "products-completed operations hazard" for any "consolidated (Wrap-up) insurance program" which has been provided by the prime contractor/project manager or owner of the construction project in which you are involved.

This exclusion applies whether or not a consolidated (Wrap-up) insurance program:

- a. Provides coverage identical to that provided by this Coverage Part; or
- b. Has limits adequate to cover all claims

This exclusion does not apply if a "consolidated (Wrap-up) insurance program" covering your operations has been cancelled, non-renewed or otherwise no longer applies for reasons other than exhaustion of all available limits, whether such limits are available on a primary, excess or on any other basis. You must advise us of such cancellation, nonrenewal or termination as soon as practicable.

For purposes of this exclusion a "consolidated (wrap-up) insurance program" is a program providing insurance coverage to all parties for exposures involved with a particular (typically major) construction project.

C. SUPPLEMENTARY PAYMENTS - COVERAGES A AND B is amended:**1. To read SUPPLEMENTARY PAYMENTS****2. Bail Bonds**

Item 1.b. is amended as follows:

b. Up to \$1,000 for cost of bail bonds required because of accidents or traffic law violations arising out of the use of any vehicle to which the Bodily Injury Liability Coverage applies. We do not have to furnish these bonds.

3. Loss of Earnings

Item 1.d. is amended as follows:

d. All reasonable expenses incurred by the insured at our request to assist us in the investigation or defense of the claim or "suit", including actual loss of earnings up to \$500 a day because of time off from work.

4. The following language is added to Item 1.

However, we shall have none of the duties set forth above when this insurance applies only for **Voluntary Property Damage Coverage** and/or **Care, Custody or Control Property Damage Coverage** and we have paid the Limit of Liability or the Aggregate Limit for these coverages.

SECTION II- WHO IS AN INSURED**A. The following change is made:****Extended Reporting Requirements**

Item 3.a. is deleted and replaced by the following:

a. Coverage under this provision is afforded only until the 180th day after you acquire or form the organization or the end of the policy period, whichever is earlier.

B. The following provisions are added**4. BROAD FORM NAMED INSURED**

Item 1.f. is added as follows:

f. Any legally incorporated entity of which you own more than 50 percent of the voting stock during the policy period only if there is no other similar insurance available to that entity. However:

(1) Coverage A does not apply to "bodily injury" or "property damage" that occurred before you acquired more than 50 percent of the voting stock; and

(2) Coverage B does not apply to "personal and advertising injury" arising out of an offense committed before you acquired more than 50 percent of the voting stock.

5. Additional Insured - Owners, Lessees or Contractors - Automatic Status When Required in Construction or Service Agreement With You

a. Any person or organization for whom you are performing operations when you and such person or organization have agreed in writing in a contract or agreement that such person or organization be added as an additional insured on your policy is an insured. Such person or organization is an additional insured only with respect to your liability for "bodily injury", "property damage" or "personal and advertising injury" which may be imputed to that person or organization directly arising out of:

1. Your acts or omissions; or

2. The acts or omissions of those acting on your behalf;

in the performance of your ongoing operations for the additional insured.

However, the insurance afforded to such additional insured:

1. Only applies to the extent permitted by law; and

2. Will not be broader than that which you are required by the contract or agreement to provide for such additional insured.

b. With respect to the insurance afforded to these additional insureds, the following additional exclusions apply:

This insurance does not apply to:



1. "Bodily injury", "property damage" or "personal and advertising injury" arising out of the rendering of, or the failure to render, any professional architectural, engineering or surveying services, including:
 - a. The preparing, approving, or failing to prepare or approve, maps, shop drawings, opinions, reports, surveys, field orders, change orders or drawings and specifications; or
 - b. Supervisory, inspection, architectural or engineering activities.

This exclusion applies even if the claims against any insured allege negligence or other wrongdoing in the supervision, hiring, employment, training or monitoring of others by that insured, if the "occurrence" which caused the "bodily injury" or "property damage", or the offense which caused the "personal and advertising injury", involved the rendering of or the failure to render any professional architectural, engineering or surveying services.

2. "Bodily injury" or "property damage" occurring after:
 - a. All work, including materials, parts or equipment furnished in connection with such work, on the project (other than service, maintenance or repairs) to be performed by or on behalf of the additional insured(s) at the location of the covered operations has been completed; or
 - b. That portion of "your work" out of which the injury or damage arises has been put to its intended use by any person or organization other than another contractor or subcontractor engaged in performing operations for a principal as a part of the same project.

6. Additional Insured – Limited Products Completed Operations Coverage

- a. Any person(s) or organization(s), but only with respect to your liability for "bodily injury" or "property damage" which may be imputed to that person(s) or organization(s) directly arising out of "your work" performed for that additional insured and included in the "products-completed operations hazard" is an insured.

However:

- (1) The insurance afforded to such additional insureds only applies to the extent permitted by law;
- (2) If coverage provided to the additional insured is required by a contract or agreement, the insurance afforded to such additional insured will not be broader than that which you are required by the contract or agreement to provide for such additional insured.
- (3) Coverage will cease five years from the completion of "your work" if:
 - (a) a time frame is not stipulated in the written contract or written agreement; or
 - (b) a time frame longer than 5 years is stipulated in the written contract or written agreement

However if a lesser time frame is stipulated in the written contract or written agreement then that time frame will prevail.

- b. With respect to the insurance afforded to any additional insured under this endorsement, the following additional exclusionary language shall apply:

This insurance does not apply to "bodily injury" or "property damage" arising out of the rendering of, or the failure to render, any professional architecture, engineering or surveying services, including:

- (1) The preparing, approving, or failing to prepare or approve, maps, shop drawings, opinions, reports, surveys, field orders, change orders or drawings and specifications; or
- (2) Supervisory, inspection, architectural or engineering activities.

7. Additional Insured - Vendors

- a. Any person(s) or organization(s) (referred to throughout this additional coverage as vendor), but only with respect to "bodily injury" or "property damage", which may be imputed to that person(s) or organization(s) arising out of "your products" shown with the Schedule which are distributed or sold in the regular course of the vendor's business is an insured.

However:

- (1) The insurance afforded to such vendor only applies to the extent permitted by law; and
- (2) If coverage provided to the vendor is required by a contract or agreement, the insurance afforded to such vendor will not be broader than that which you are required by the contract or agreement to provide for such vendor.

b. With respect to the insurance afforded to these vendors, the following additional exclusions apply:

- (1) This insurance afforded the vendor does not apply to:
 - (a) "Bodily injury" or "property damage" for which the vendor is obligated to pay damages by reason of the assumption of liability in a contract or agreement. This exclusion does not apply to liability for damages that the vendor would have in the absence of the contract or agreement;
 - (b) Any express warranty unauthorized by you;
 - (c) Any physical or chemical change in the product made intentionally by the vendor;
 - (d) Repackaging, except when unpacked solely for the purpose of inspection, demonstration, testing, or the substitution of parts under instructions from the manufacturer, and then repackaged in the original container.
 - (e) Any failure to make such inspections, adjustments, tests or servicing as the vendor has agreed to make or normally undertakes to make in the usual course of business, in connection with the distribution or sale of products.
 - (f) Demonstration, installation, servicing or repair operations, except such operations performed at the vendor's premises in connection with the sale of the product.
 - (g) Products which, after distribution or sale by you, have been labeled or relabeled or used as a container, part or ingredient of any other thing or substance by or for the vendor.
 - (h) "Bodily injury" or "property damage" arising out of the sole negligence of the vendor for its own acts or omissions or those of its employees or anyone else acting on its behalf. However, this exclusion does not apply to:
 - i. The exceptions contained in Sub-paragraphs d. or f.; or
 - ii. Such inspections, adjustments, tests or servicing as the vendor has agreed to make or normally undertakes to make in the usual course of business, in connection with the distribution or sale of the products.
- (2) This insurance does not apply to any insured person or organization, from whom you have acquired such products, or any ingredient, part or container, entering into, accompanying or containing such products.

8. Additional Insured – Lessor of Leased Equipment – Automatic Status When Required in Lease Agreement With You

- a. Any person(s) or organization(s) from whom you lease equipment when you and such person(s) or organization(s) have agreed in writing in a contract or agreement that such person(s) or organization(s) be added as an additional insured on your policy. Such person(s) or organization(s) is an insured only with respect to your liability for "bodily injury", "property damage" or "personal and advertising injury" directly arising out of the maintenance, operation or use of equipment leased to you, which may be imputed to such person or organization as the lessor of equipment.

However, the insurance afforded to such additional insured:

- (1) Only applies to the extent permitted by law; and
- (2) Will not be broader than that which you are required by the contract or agreement to provide for such additional insured.

A person's or organization's status as an additional insured under this endorsement ends when their contract or agreement with you for such leased equipment ends.

- b. With respect to the insurance afforded to these additional insureds, this insurance does not apply to any "occurrence" which takes place after the equipment lease expires.

9. Additional Insured – Managers or Lessors of Premises

- a. Any person(s) or organization(s), but only with respect to liability arising out of the ownership, maintenance or use of that part of the premises leased to you and subject to the following additional exclusions:



This insurance does not apply to:

- (1) Any "occurrence" which takes place after you cease to be a tenant in that premises.
- (2) Structural alterations, new construction or demolition operations performed by or on behalf of the person(s) or organization(s) afforded coverage by the additional coverage.

However:

- (1) The insurance afforded to such additional insured only applies to the extent permitted by law; and
- (2) If coverage provided to the additional insured is required by a contract or agreement, the insurance afforded to such additional insured will not be broader than that which you are required by the contract or agreement to provide for such additional insured.

10. Additional Insured - Engineers, Architects or Surveyors Not Engaged by the Named Insured

- a. Any architects, engineers or surveyors who are not engaged by you are insureds, but only with respect to liability for "bodily injury" or "property damage" or "personal and advertising injury" which may be imputed to that architect, engineer or surveyor arising out of:

- (1) Your acts or omissions; or
- (2) Your acts or omissions of those acting on your behalf;

in the performance of your ongoing operations performed by you or on your behalf.

But only if such architects, engineers or surveyors, while not engaged by you, are contractually required to be added as an additional insured to your policy.

However, the insurance afforded to such additional insured:

- (1) Only applies to the extent permitted by law; and
- (2) Will not be broader than that which you are required by the contract or agreement to provide for such additional insured.

- b. With respect to the insurance afforded to these additional insureds, the following additional exclusion applies:

This insurance does not apply to "bodily injury", "property damage" or "personal and advertising injury" arising out of the rendering of or failure to render any professional services, including:

- (1) The preparing, approving, or failing to prepare or approve, maps, drawings, opinions, reports, surveys, change orders, designs or specifications; or
- (2) Supervisory, inspection or engineering services.

This exclusion applies even if the claims against any insured allege negligence or other wrongdoing in the supervision, hiring, employment, training or monitoring of others by that insured, if the "occurrence" which caused the "bodily injury" or "property damage", or the offense which caused the "personal and advertising injury", involved the rendering of or the failure to render any professional services.

11. Additional Insured - State or Governmental Agency or Subdivision or Political Subdivision - Permits or Authorizations

Any state or governmental agency or subdivision or political subdivision is an insured, subject to the following provisions:

- a. This insurance applies only with respect to operations performed by you or on your behalf for which the state or governmental agency or subdivision or political subdivision has issued a permit or authorization.

However:

- (1) The insurance afforded to such additional insured only applies to the extent permitted by law; and
- (2) If coverage provided to the additional insured is required by a contract or agreement, the insurance afforded to such additional insured will not be broader than that which you are required by the contract or agreement to provide for such additional insured.

b. This insurance does not apply to:

- (1) "Bodily injury", "property damage" or "personal and advertising injury" arising out of operations performed for the federal government, state or municipality; or
- (2) "Bodily injury" or "property damage" included within the "products-completed operations hazard".

12. Additional Insured Consolidated Insurance Program (Wrap-Up) Off-Premises Operations Only - Owners, Lessees or Contractors

a. Any persons or organizations for whom you are performing operations, for which you have elected to seek coverage under a Consolidated Insurance Program, when you and such person or organization have agreed in writing in a contract or agreement that such person or organization be added as an additional insured on your policy is an insured. Such person or organization is an additional insured only with respect to your liability which may be imputed to that person or organization directly arising out of your ongoing operations performed for that person or organization at a premises other than any project or location that is designated as covered under a Consolidated Insurance Program. A person's or organization's status as an insured under this endorsement ends when your operations for that insured are completed.

b. With respect to the insurance afforded to these additional insureds, the following additional exclusion applies.

This insurance does not apply to:

"Bodily injury", "property damage", or "personal and advertising injury" arising out of the rendering of, or failure to render, any professional architectural, engineering or surveying services, including:

- (1) The preparing, approving, or failing to prepare or approve, maps, shop drawings, opinions, reports, surveys, field orders, change orders or drawings and specifications; and
- (2) Supervisory, inspection

13. Additional Insured - Employee Injury to Another Employee

With respect to your "employees" who occupy positions which are supervisory in nature:

Paragraph 2.a.(1) of **SECTION II – WHO IS A NAMED INSURED** is amended to read:

a. "Bodily injury" or "personal and advertising injury"

- (1) To you, to your partners or members (if you are a partnership or joint venture), or to your members (if you are a limited liability company);
- (2) For which there is any obligation to share damages with or repay someone else who must pay damages because of the injury described in paragraph (1)(a) above; or
- (3) Arising out of his or her providing or failing to provide professional healthcare services. Paragraph 3.a. is deleted.

For the purpose of this Item 12 only, a position is deemed to be supervisory in nature if that person performs principle work which is substantially different from that of his or her subordinates and has authority to hire, direct, discipline or discharge.

SECTION III - LIMITS OF INSURANCE

A. The following items are deleted and replaced by the following:

2. The General Aggregate Limit is the most we will pay for the sum of:

- a. Medical expenses under Coverage C;
- b. Damages under Coverage A, except damages because of "bodily injury" or "property damage" included in the "products-completed operations hazard"; and
- c. Damages under Coverage B; and
- d. Damages under Coverage H.



3. The Products-Completed Operations Aggregate Limit is the most we will pay under Coverage A for damages because of "bodily injury" and "property damage" included in the "products-completed operations hazard" and Coverage G.
6. Subject to 5. above, the Damage to Premises Rented to You Limit is the most we will pay under Coverage A for damages because of "property damage" to any one premises, while rented to you, or in the case of damage by fire, explosion, lightning, smoke resulting from such fire, explosion, or lightning or sprinkler leakage while rented to you or temporarily occupied by you with permission of the owner.

B. The following are added:

8. Subject to Paragraph 5. of **SECTION III – LIMITS OF INSURANCE** \$25,000 is the most we will pay under Coverage H for **Water Damage Legal Liability**.

9. Coverage G- Product Recall Expense

Aggregate Limit \$50,000

Each Product Recall Limit \$25,000

- a. The Aggregate Limit shown above is the most we will pay for the sum of all "product recall expense" you incur as a result of all "product recalls" you initiate during the endorsement period.
- b. The Each Product Recall Limit shown above is the most we will pay, subject to the Aggregate and \$1,000 deductible, for "product recall expense" you incur for any one "product recall" you initiate during the endorsement period.

We will only pay for the amount of Product Recall Expenses which are in excess of the deductible amount. The deductible applies separately to each Product Recall. The limits of insurance will not be reduced by the amount of this deductible.

We may, or will if required by law, pay all or any part of any deductible amount. Upon notice of our payment of a deductible amount, you shall promptly reimburse us for the part of the deductible amount we paid.

10. Aggregate Limits of Insurance (Per Location)

The General Aggregate Limit applies separately to each of your "locations" owned by or rented to you or temporarily occupied by you with the permission of the owner.

"Location" means premises involving the same or connecting lots, or premises whose connection is interrupted only by a street, roadway, waterway or right-of-way of a railroad.

11. Aggregate Limits of Insurance (Per Project)

The General Aggregate Limit applies separately to each of your projects away from premises owned by or rented to you.

12. With respects to the insurance afforded to additional insureds afforded coverage by items 5 through 13 of **SECTION II – WHO IS AN INSURED** above, the following is added:

The most we will pay on behalf of the additional insured is the amount of insurance:

- a. Required by the contract or agreement;
- b. Available under the applicable Limits of Insurance shown in the Declarations;
- Whichever is less.

This endorsement shall not increase the applicable Limits of Insurance shown in the Declarations.

13. Subject to 5. of **SECTION III – LIMITS OF INSURANCE**, a \$5,000 "occurrence" limit and a \$10,000 "aggregate" limit is the most we will pay under Coverage A for damages because of "property damage" covered under **Coverage D - Voluntary Property Damage Coverage**.

For the purposes of this Voluntary Property Damage Coverage, our right and duty to defend ends when we have paid the Limit of Liability or the Aggregate Limit for this coverage.

14. Subject to 5. of **SECTION III – LIMITS OF INSURANCE**, a \$25,000 "occurrence" limit and a \$100,000 "aggregate" limit is the most we will pay under **Coverage E - Care, Custody and Control Coverage** regardless of the number of:
- Insureds;
 - Claims made or "suits" brought; or
 - Persons or organizations making claims or bringing "suits".

Deductible - Our obligation to pay damages on your behalf applies only to the amount of damages in excess of \$500.

This deductible applies to all damages because of "property damage" as the result of any one "occurrence" regardless of the number of persons or organizations who sustain damages because of that "occurrence".

We may pay any part or all of the deductible amount to effect settlement of any claim or "suit" and upon notification of the action taken, you shall promptly reimburse us for such part of the deductible amount as has been paid by us.

As respects this coverage "Aggregate" is the maximum amount we will pay for all covered "occurrences" during one policy period.

For the purposes of this Care, Custody and Control Property Damage Coverage, our right and duty to defend ends when we have paid the Limit of Liability or the Aggregate Limit for this coverage.

15. Subject to 5. of **SECTION III – LIMITS OF INSURANCE**, the most we will pay for "property damage" under **Coverage F - Electronic Data Liability Coverage** for loss of "electronic data" is \$50,000 without regard to the number of "occurrences".

SECTION IV - COMMERCIAL GENERAL LIABILITY CONDITIONS

A. The following conditions are amended:

1. Knowledge of Occurrence

a. Condition 2., Items a. and b. are deleted and replaced by the following:

(1) Duties In The Event Of Occurrence, Offense, Claim Or Suit

(a) You must see to it that we are notified as soon as practicable of an "occurrence" or an offense which may result in a claim. Knowledge of an "occurrence" by your agent, servant or employee shall not in itself constitute knowledge of the named insured unless an officer of the named insured has received such notice from the agent, servant or employee. To the extent possible, notice should include:

- How, when and where the "occurrence" took place;
- The names and addresses of any injured persons and witnesses, and
- The nature and location of any injury or damage arising out of the "occurrence" or offense.

(b) If a claim is made or "suit" is brought against any insured, you must:

- Immediately record the specifics of the claim or "suit" and the date received; and
- Notify us as soon as practicable.

You must see to it that we receive written notice of the claim or "suit" as soon as practicable. Knowledge of a claim or "suit" by your agent, servant or employee shall not in itself constitute knowledge of the named insured unless an officer of the named insured has received such notice from the agent, servant or employee.

2. Where **Broad Form Named Insured** is added in **SECTION II – WHO IS AN INSURED** of this endorsement, Condition 4. **Other Insurance b. Excess Insurance (1).(a)** is replaced by the following:

(a) Any of the other insurance, whether primary, excess, contingent or on any other basis, that is available to an insured solely by reason of ownership by you of more than 50 percent of the voting stock, and not withstanding any other language in any other policy. This provision does not apply to a policy written to apply specifically in excess of this policy.



B. The following are added:

1. Condition (5) of 2.c.

(5) Upon our request, replace or repair the property covered under Voluntary Property Damage Coverage at your actual cost, excluding profit or overhead.

10. Blanket Waiver Of Subrogation

We waive any right of recovery we may have against any person or organization because of payments we make for injury or damage arising out of: premises owned or occupied by or rented or loaned to you, ongoing operations performed by you or on your behalf, done under a contract with that person or organization, "your work", or "your products". We waive this right where you have agreed to do so as part of a written contract, executed by you before the "bodily injury" or "property damage" occurs or the "personal injury" or "advertising injury" offense is committed.

11. Liberalization

If a revision to this Coverage Part, which would provide more coverage with no additional premium becomes effective during the policy period in the state designated for the first Named Insured shown in the Declarations, your policy will automatically provide this additional coverage on the effective date of the revision.

12. Unintentional Failure to Disclose All Hazards

Based on our reliance on your representations as to existing hazards, if you unintentionally should fail to disclose all such hazards at the inception date of your policy, we will not deny coverage under this Coverage Part because of such failure. However, this provision does not affect our right to collect additional premium or exercise our right of cancellation or non-renewal.

13. The following conditions are added in regard to Coverage G - Product Recall Expense

In event of a "product recall", you must

- a. See to it that we are notified as soon as practicable of a "product recall". To the extent possible, notice should include how, when and where the "product recall" took place and estimated "product recall expense".
- b. Take all reasonable steps to minimize "product recall expense". This will not increase the limits of insurance.
- c. If requested, permit us to question you under oath at such times as may be reasonably required about any matter relating to this insurance or your claim, including your books and records. Your answers must be signed.
- d. Permit us to inspect and obtain other information proving the loss. You must send us a signed, sworn statement of loss containing the information we request to investigate the claim. You must do this within 60 days after our request.
- e. Cooperate with us in the investigation or settlement of any claim.
- f. Assist us upon our request, in the enforcement of any rights against any person or organization which may be liable to you because of loss to which this insurance applies.

14. Limited Railroad Contractual Liability

The following conditions are applicable only to coverage afforded by reason of the redefining of an "insured contract" in the **DEFINITIONS** section of this endorsement:

- a. Railroad Protective Liability coverage provided by ISO form CG 0035 with minimum limits of \$2,000,000 per occurrence and a \$6,000,000 general aggregate limit must be in place for the entire duration of any project.
- b. Any amendment to the Other Insurance condition of form CG 0035 alters the primacy of the coverage or which impairs our right to contribution will rescind any coverage afforded by the redefined "insured contract" language.
- c. For the purposes of the Other Insurance condition of form CG 0035 you, the named insured, will be deemed to be the designated contractor.

SECTION V – DEFINITIONS

- A. At item 12. **Mobile Equipment** the wording at f.(1) is deleted and replaced by the following:
- f.(1) Equipment designed primarily for:
- (a) Snow removal;
 - (b) Road maintenance, but not construction or resurfacing; or
 - (c) Street cleaning;
- except for such vehicles that have a gross vehicle weight less than 1,000 lbs which are not designed for highway use.
- B. Item 3. **"bodily injury"** is deleted and replaced with the following:
3. "bodily injury" means physical injury, sickness or disease sustained by a person. This includes mental anguish, mental injury, shock, fright or death that results from such physical injury, sickness or disease.
- C. Item 9. **"Insured Contract"** c. is deleted and replaced with the following:
- c. Any easement or license agreement;
- D. Item 9. **"Insured Contract"** f.(1) is deleted
- E. The following definitions are added for this endorsement only
23. **"Electronic data"** means information, facts or programs stored as or on, created or used on, or transmitted to or from computer software, including systems and applications software, hard or floppy disks, CD-ROMS, tape drives, cells, data processing devices or any other media which are used with electronically controlled equipment.
24. **"Product recall"** means a withdrawal or removal from the market of "your product" based on the determination by you or any regulatory or governmental agency that:
- a. The use or consumption of "your product" has caused or will cause actual or alleged "bodily injury" or "property damage"; and
 - b. Such determination requires you to recover possession or control of "your product" from any distributor, purchaser or user, to repair or replace "your product", but only if "your product" is unfit for use or consumption, or is hazardous as a result of:
 - (1) An error or omission by an insured in the design, manufacturing, processing, labeling, storage, or transportation of "your product"; or
 - (2) Actual or alleged intentional, malicious or wrongful alteration or contamination of "your product" by someone other than you.
25. **"Product recall expense"** means reasonable and necessary expenses for:
- a. Telephone, radio and television communication and printed advertisements, including stationery, envelopes and postage.
 - b. Transporting recalled products from any purchaser, distributor or user, to locations designated by you.
 - c. Remuneration paid to your employees for overtime, as well as remuneration paid to additional employees or independent contractors you hire.
 - d. Transportation and accommodation expense incurred by your employees.
 - e. Rental expense incurred for temporary locations used to store recalled products.
 - f. Expense incurred to properly dispose of recalled products, including packaging that cannot be reused.
 - g. Transportation expenses incurred to replace recalled products.
 - h. Repairing, redistributing or replacing covered recalled products with like products or substitutes, not to exceed your original cost of manufacturing, processing, acquisition and/or distribution.

These expenses must be incurred as a result of a "product recall".



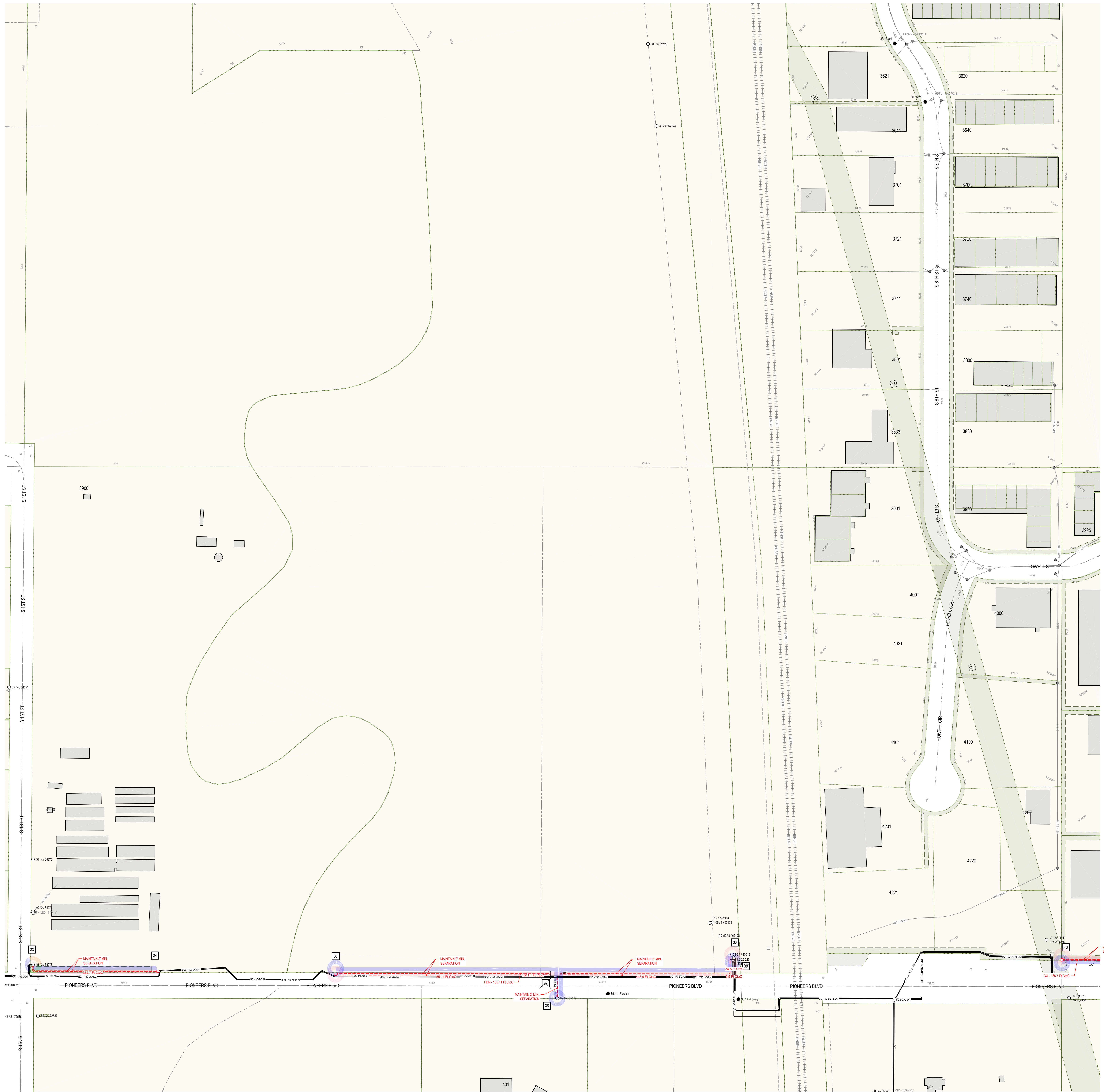

NORTH

LEGEND:

---	SPARE 2" SMOOTHWALL DUCT - "X" ROUTE
---	SPARE 2" SMOOTHWALL DUCT - "Y" ROUTE
---	SPARE 2" SMOOTHWALL DUCT - "Z" ROUTE
---	SPARE 2" SMOOTHWALL DUCT - "DECK" ROUTE
---	SPARE 2" OR 4" SMOOTHWALL DUCT (PROPOSED)
---	EXISTING SMOOTHWALL DUCT - "W" USE
---	EASEMENT (EXISTING)
---	EASEMENT (PROPOSED)
---	UNDERGROUND PRIMARY CONDUCTOR
---	UNDERGROUND SECONDARY CONDUCTOR
---	UNDERGROUND SERVICE
△	PADMOUNT TRANSFORMER, 10
▲	PADMOUNT TRANSFORMER, 30
○	DISTRIBUTION POLE
○	DISTRIBUTION PEDESTAL
⊕	STREET LIGHT, MAST ARM
⊕	STREET LIGHT, POST TOP

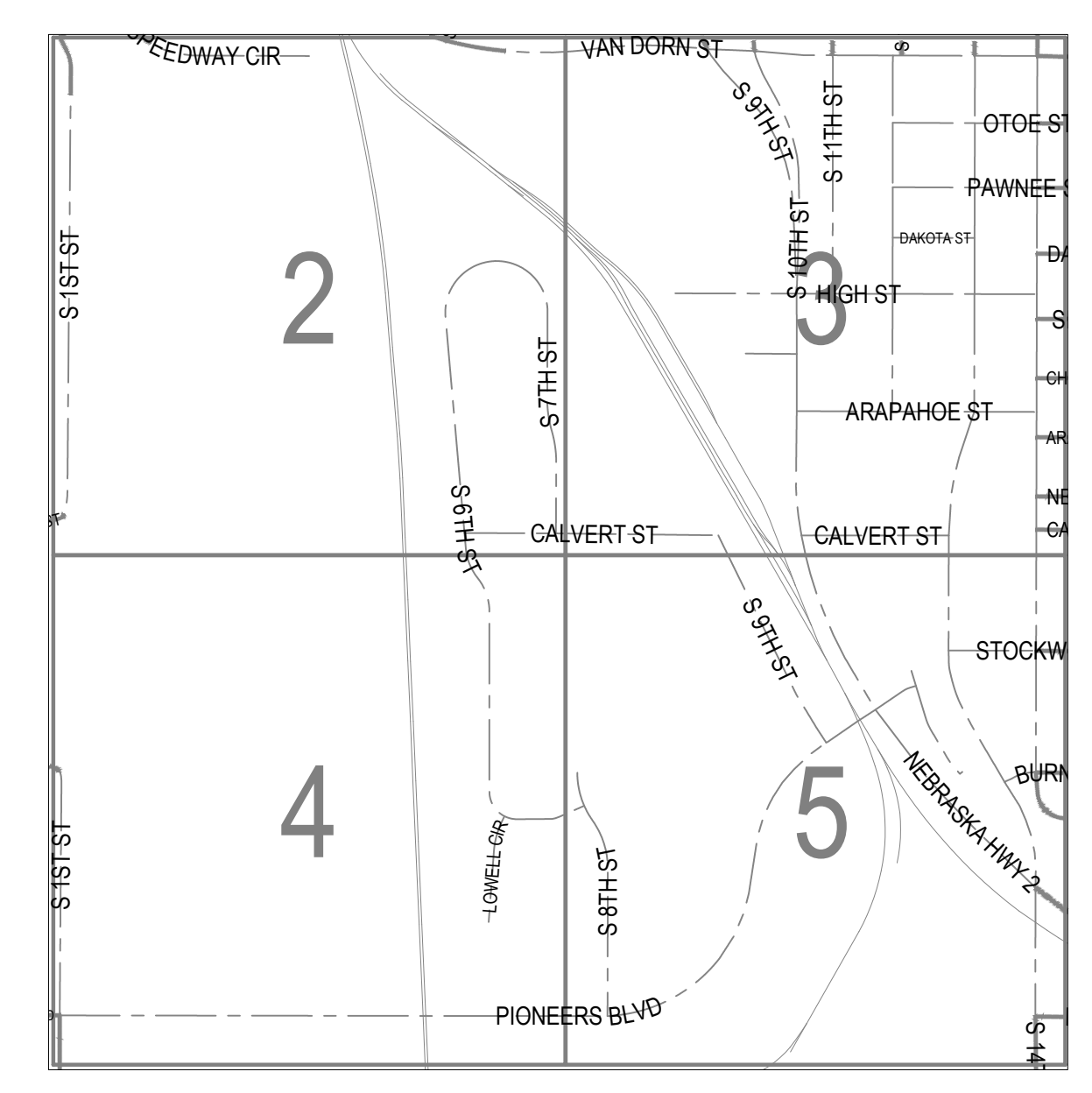

- CONSTRUCTION NOTES:
- (1) MAINTAIN 1" VERTICAL AND 3" HORIZONTAL SEPARATION BETWEEN LES DUCTS AND ANY UTILITY. POTHOLES WILL BE REQUIRED EVERY 30' PRIOR TO INSTALLING DUCT WITHIN 3' OF ANY UTILITY.
 - (2) CONTRACTOR WILL INSTALL SMOOTHWALL DUCTS INTO THE EXISTING TRANSFORMER SECONDARY COMPARTMENT (SEE TYPICAL CONDUIT INSTALLATION DETAILS).
 - (3) ALL DUCTS AND EQUIPMENT SHALL BE INSTALLED IN ITS DESIGNED LOCATION AS INDICATED ON THE CONSTRUCTION DOCUMENTS. ALL DUCTS AND EQUIPMENT ARE REQUIRED TO BE INSTALLED ON LES EASEMENT OR IN THE LES STANDARD RIGHT-OF-WAY CORRIDOR 3' FROM PROPERTY LINE. DEVIATIONS FROM DESIGN REQUIRE REVIEW AND PRE-APPROVAL FROM LES ENGINEERING OR LES INSPECTOR.
 - (4) ALL DUCTS TO BE INSTALLED 3' FROM THE PROPERTY LINE, UNLESS OTHERWISE NOTED.
 - (5) 48" BEND RADIUS PREFERRED, 26" BEND RADIUS MINIMUM PER LES STANDARD SPECIFICATION 2225.
 - (6) WINDSTREAM AND TIME WARNER HAVE BEEN NOTIFIED OF THIS PROJECT. EXISTING CABLES FOR THE ABOVE MENTIONED UTILITIES MAY CO-EXIST IN THE TRENCH WHERE THE LES CABLE IS BEING LOCATED.
 - (7) CONTRACTOR TO USE APPROVED METHODS TO BACK TAMP AND RESTORE WORK AREA, FOLLOWING CITY SPECIFICATIONS WHILE IN RIGHT-OF-WAY.

APPROVED for CONSTRUCTION
Return Print with Corrections
Noted "As-Built"

REVISIONS		APPROVED		DATE		DESCRIPTION	
NO.	DESCRIPTION	NO.	DATE	NO.	DATE	NO.	DESCRIPTION
1	FCI, NEW TERMINATION BOX 2	1		1		1	
2		2		2		2	
3		3		3		3	
4		4		4		4	
5		5		5		5	

BASE	DATE	BY	DATE	BY	DATE	BY	DATE
DESIGNED BY		IN REVIEW		DATE		DATE	
CHECKED BY		APPROVED BY		DATE		DATE	

NO.	DESCRIPTION	DATE	BY
1	FCI, NEW TERMINATION BOX 2		
2			
3			
4			
5			

NO.	DESCRIPTION	DATE	BY
1	FCI, NEW TERMINATION BOX 2		
2			
3			
4			
5			

DRAWING NO.		DATE	
URS-0768	SH 4.07		

DUCT INSTALLATION PROJECT
2017 - AREA 07
S 1ST - S 14TH ST & VAN DORN ST - PIONEERS BLVD



NO.	DESCRIPTION	DATE	BY
1	FCI, NEW TERMINATION BOX 2		
2			
3			
4			
5			

NO.	DESCRIPTION	DATE	BY
1	FCI, NEW TERMINATION BOX 2		
2			
3			
4			
5			

NO.	DESCRIPTION	DATE	BY
1	FCI, NEW TERMINATION BOX 2		
2			
3			
4			
5			

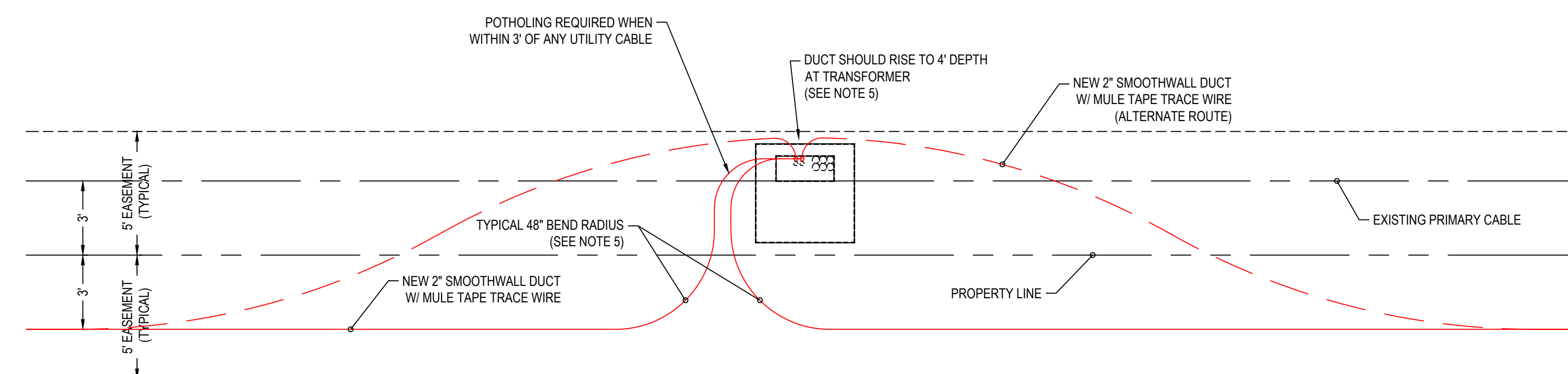

DETAIL "A" - SMOOTHWALL DIRECTIONAL BORING
(EASEMENT BOTH SIDES OF PROPERTY LINE & TRANSFORMER OPENING NOT IN LINE WITH PRIMARY)
NO SCALE

THIS DETAIL IS GENERAL INFORMATION ONLY.
FIELD CONDITIONS MAY VARY. "SEE NOTE (4)"

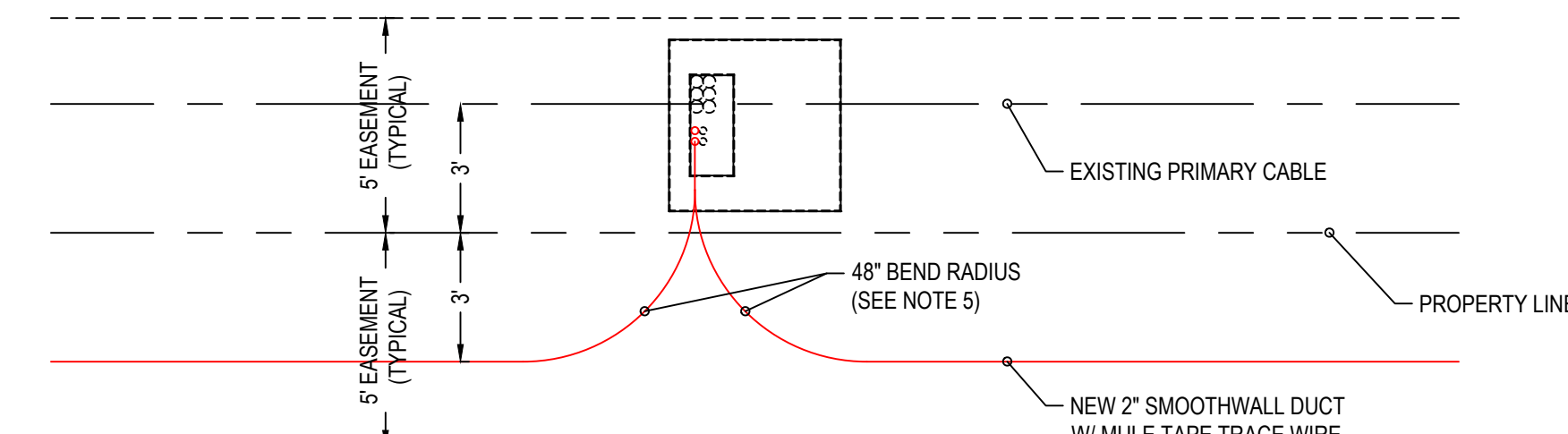

DETAIL "B" - SMOOTHWALL DIRECTIONAL BORING
(EASEMENT BOTH SIDES OF PROPERTY LINE & TRANSFORMER OPENING IN LINE WITH PRIMARY)
NO SCALE

THIS DETAIL IS GENERAL INFORMATION ONLY.
FIELD CONDITIONS MAY VARY. "SEE NOTE (4)"

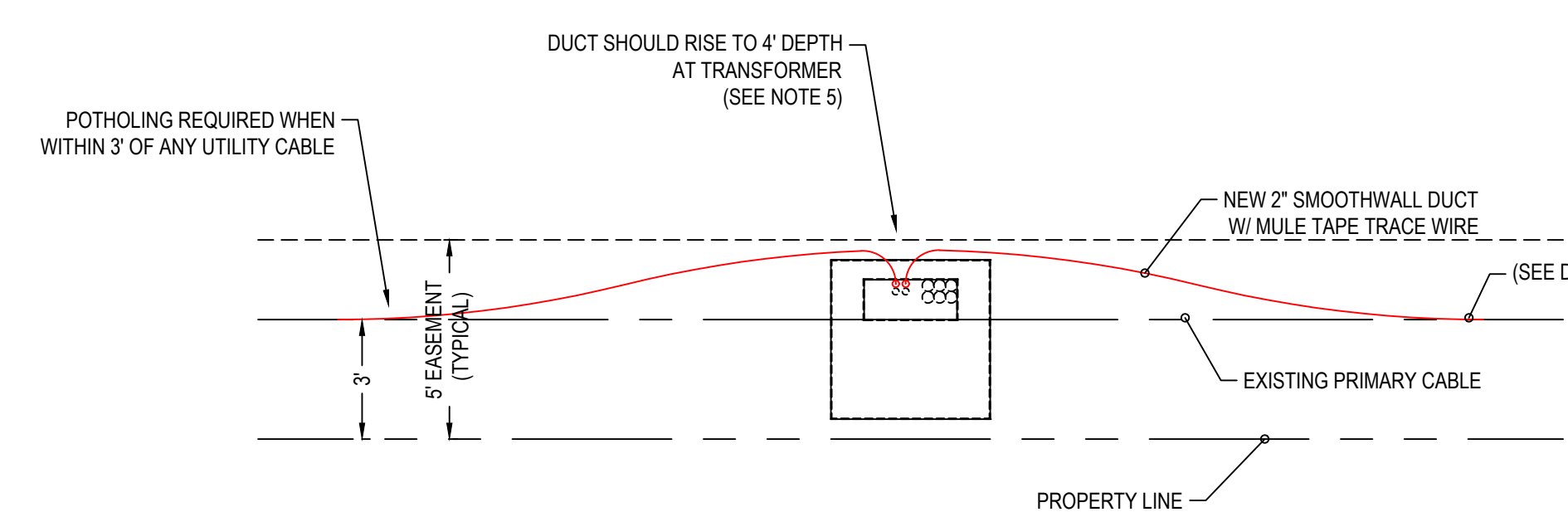

DETAIL "C" - SMOOTHWALL DIRECTIONAL BORING
(EASEMENT ONE SIDE OF PROPERTY LINE)
NO SCALE

THIS DETAIL IS GENERAL INFORMATION ONLY.
FIELD CONDITIONS MAY VARY. "SEE NOTE (4)"

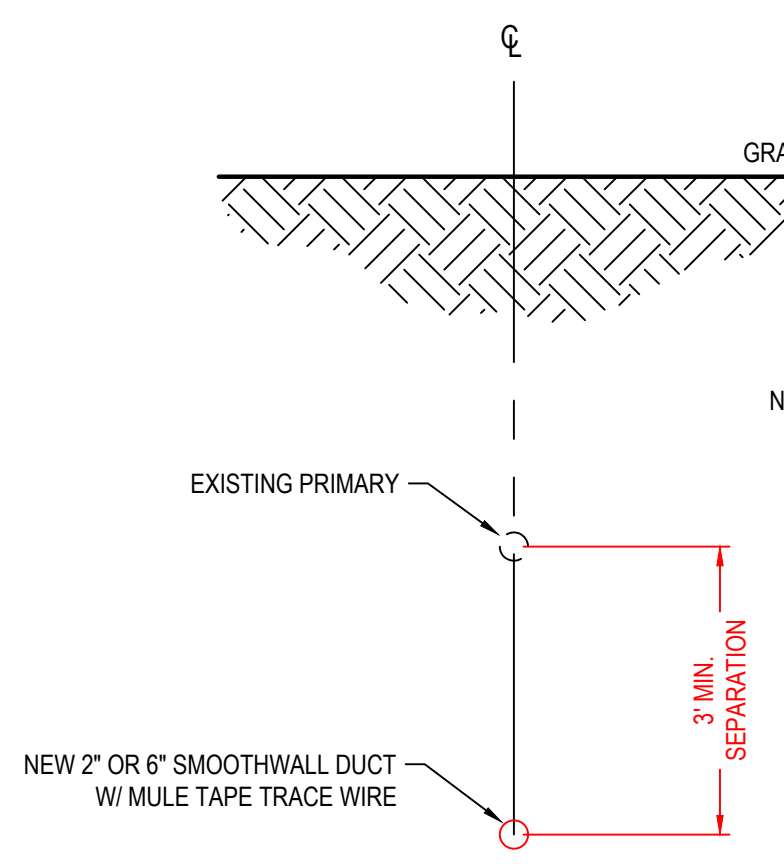

DETAIL "D" - BORE CLEARANCE
(BELOW EXISTING PRIMARY)
NO SCALE

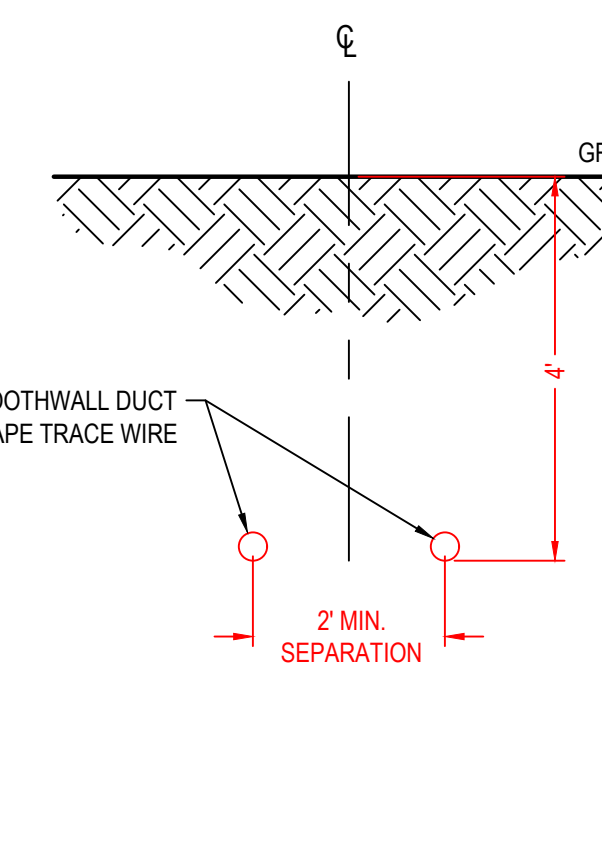

DETAIL "E" - BORE CLEARANCE
(SAME PHASE OR PHASE TO FEEDER, BELOW EXISTING PRIMARY)
NO SCALE

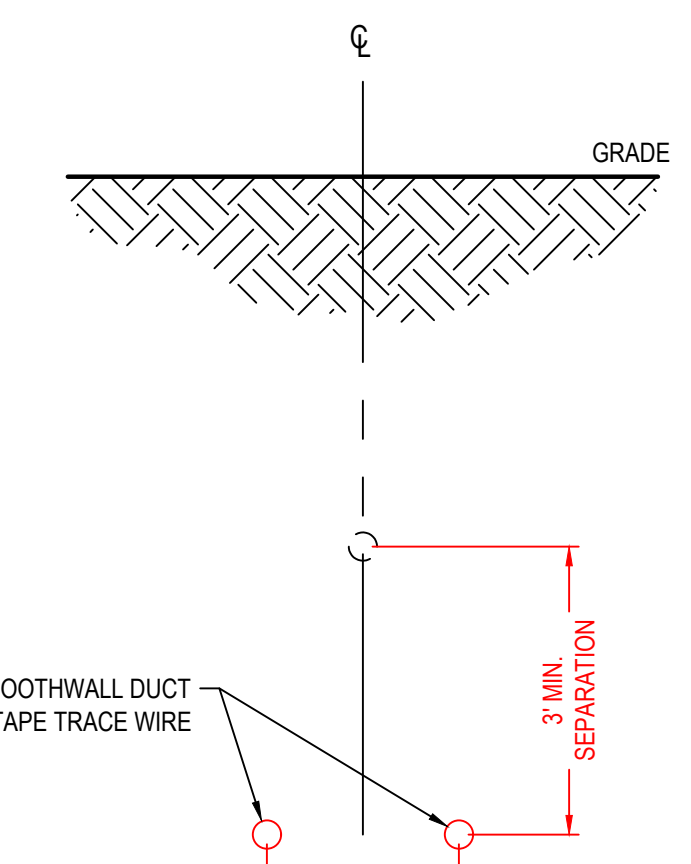

DETAIL "F" - BORE CLEARANCE
(SAME PHASE OR PHASE TO FEEDER, BELOW EXISTING PRIMARY)
NO SCALE

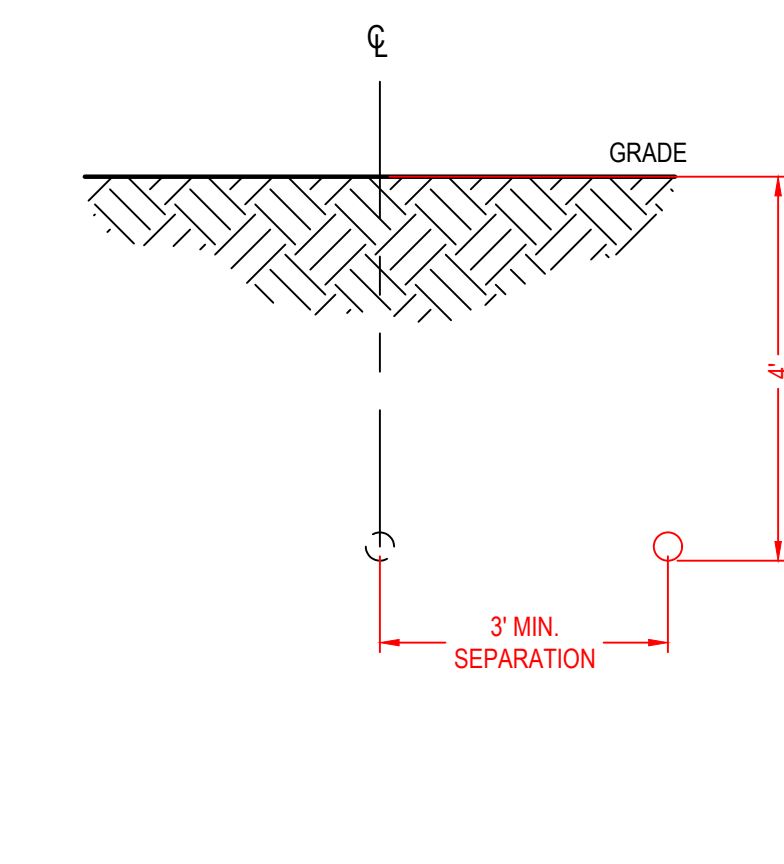

DETAIL "G" - BORE CLEARANCE
(HORIZONTAL TO EXISTING PRIMARY)
NO SCALE

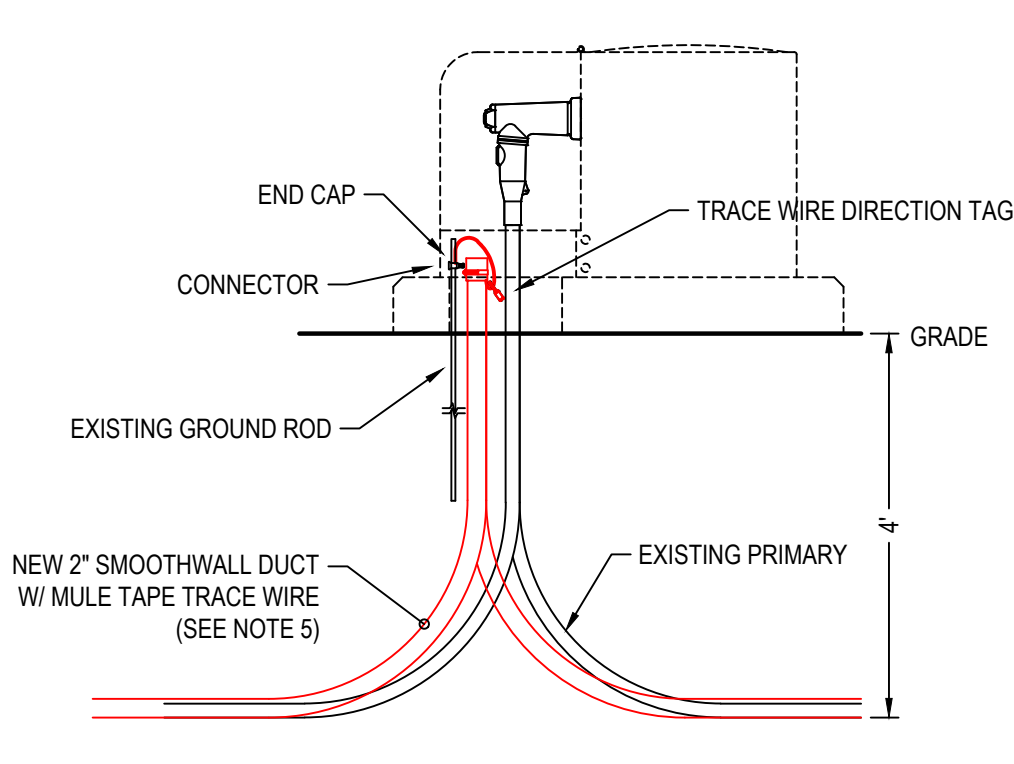

DETAIL "H" - DUCT STUB-UP AT TRANSFORMER
NO SCALE

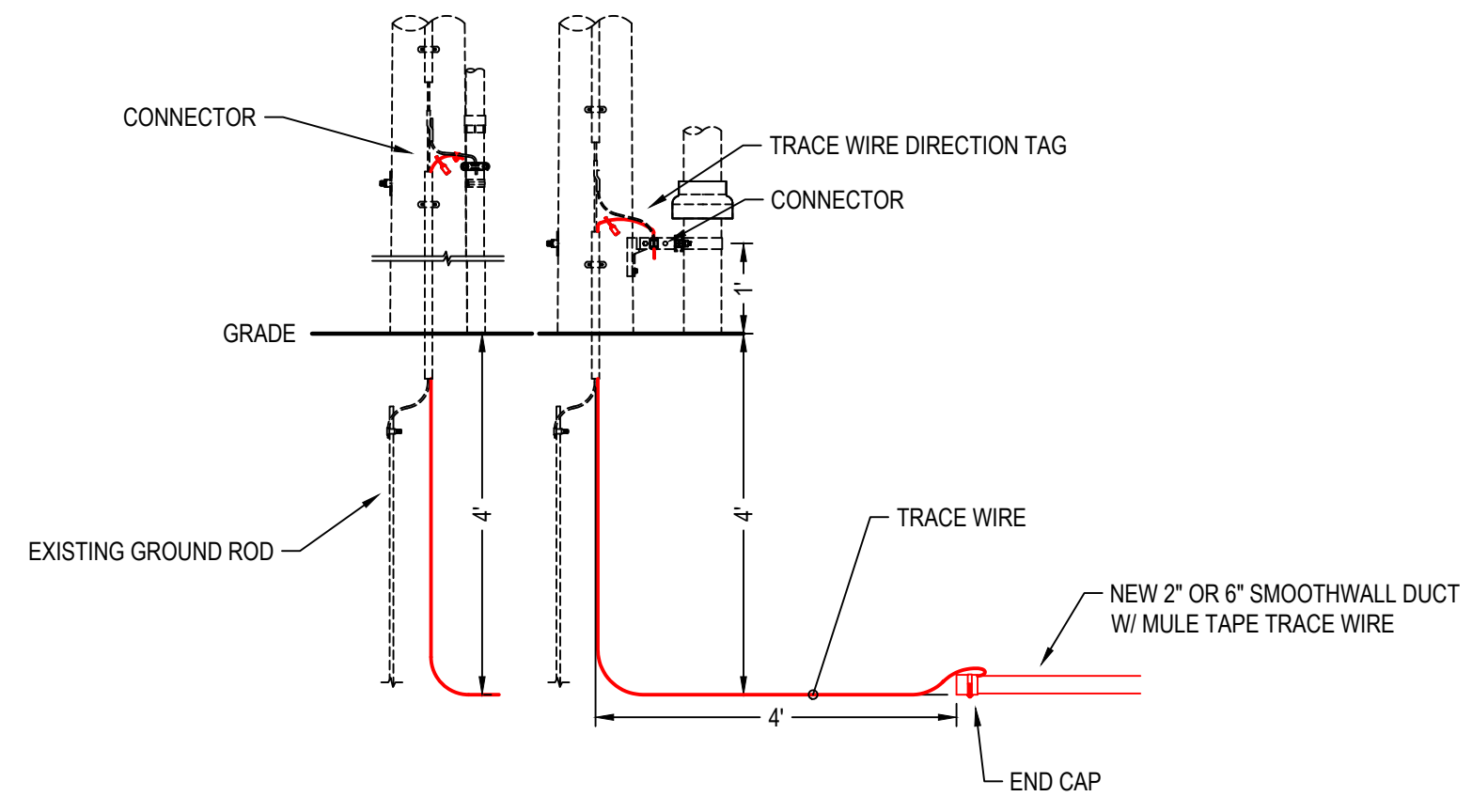

DETAIL "I" - TRACE WIRE TERMINATION AT POLE DETAIL, DUCT CAPPED BELOW GRADE
NO SCALE

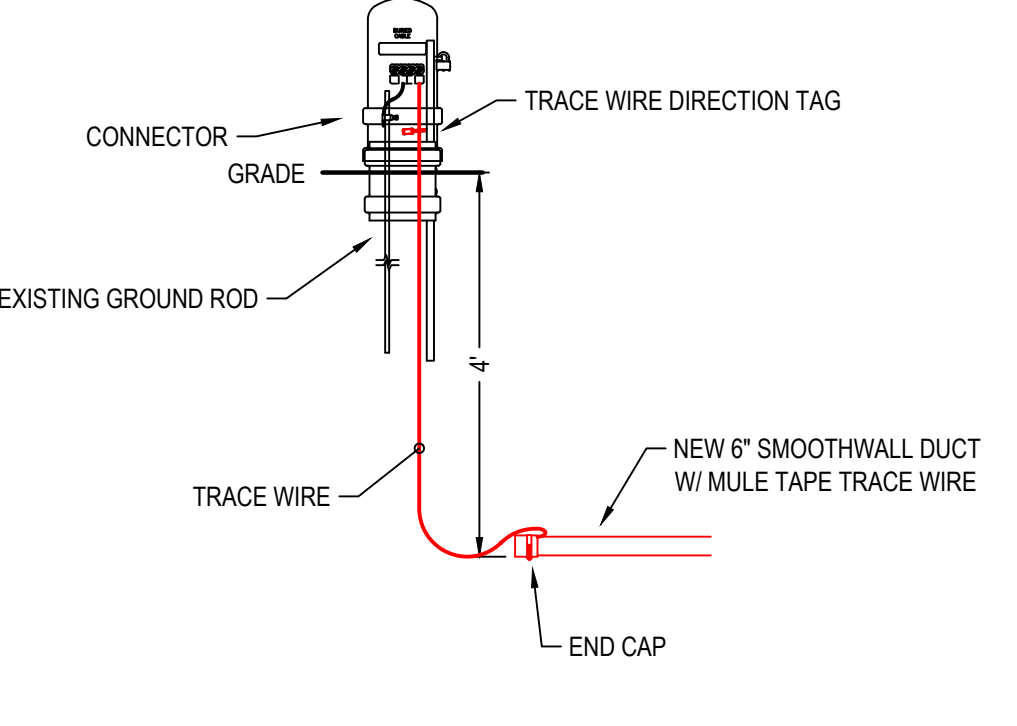

DETAIL "J" - TRACE WIRE PEDESTAL DETAIL, DUCT CAPPED BELOW GRADE
NO SCALE

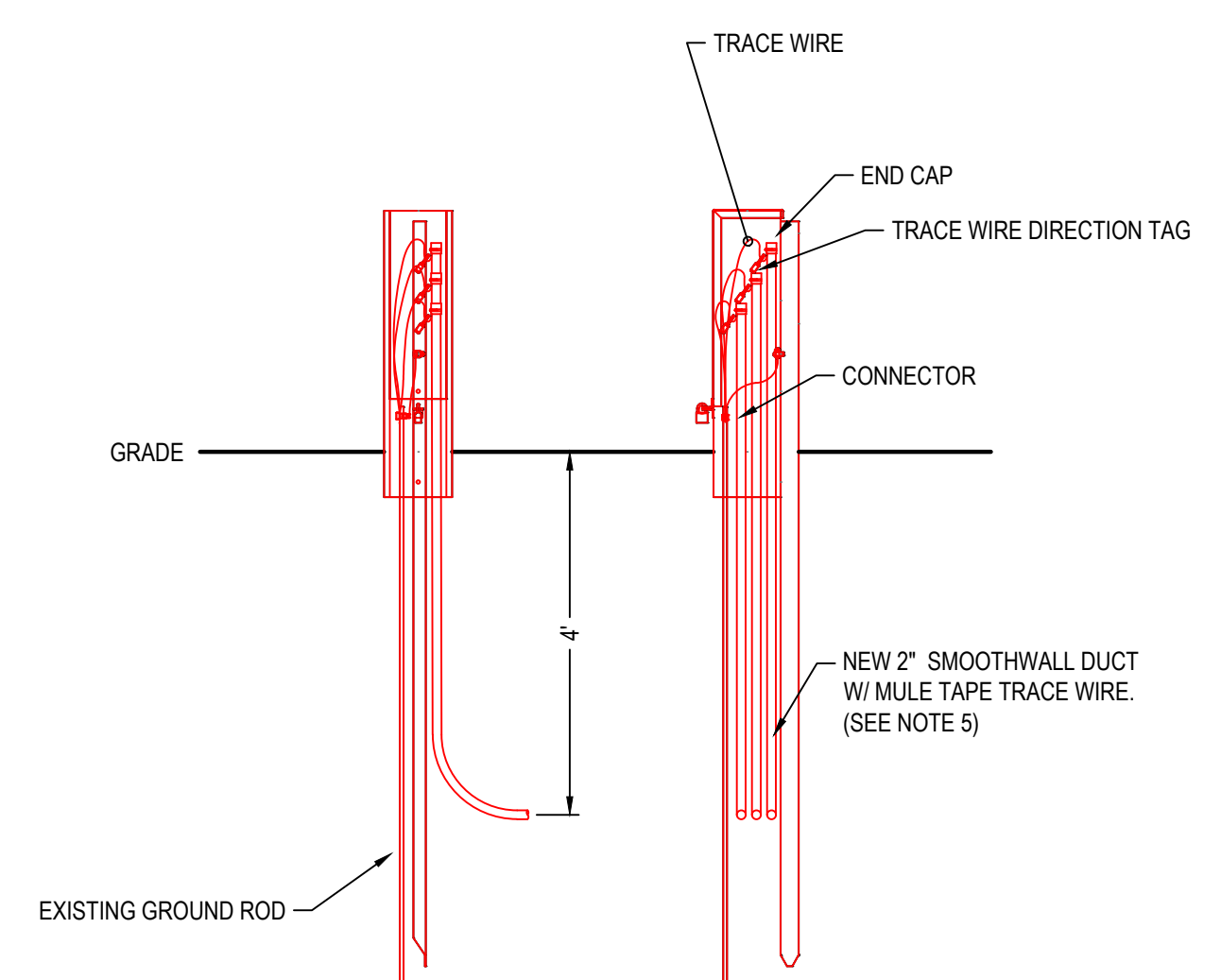

DETAIL "K" - TRACE WIRE & DUCT TERMINATION AT STUB-UP PEDESTAL
NO SCALE

- CONSTRUCTION NOTES:**
- (1) MAINTAIN 1" VERTICAL AND 3" HORIZONTAL SEPARATION BETWEEN LES DUCTS AND ANY UTILITY. POTHOLING WILL BE REQUIRED EVERY 30' PRIOR TO INSTALLING DUCT WITHIN 3' OF ANY UTILITY.
 - (2) CONTRACTOR WILL INSTALL SMOOTHWALL DUCTS INTO THE EXISTING TRANSFORMER SECONDARY COMPARTMENT (SEE TYPICAL CONDUIT INSTALLATION DETAILS).
 - (3) ALL DUCTS AND EQUIPMENT SHALL BE INSTALLED IN ITS DESIGNED LOCATION AS INDICATED ON THE CONSTRUCTION DOCUMENTS. ALL DUCTS AND EQUIPMENT ARE REQUIRED TO BE INSTALLED ON LES EASEMENT OR IN THE LES STANDARD RIGHT-OF-WAY CORRIDOR (3' FROM PROPERTY LINE). DEVIATIONS FROM DESIGN REQUIRE REVIEW AND PRE-APPROVAL FROM LES ENGINEERING OR LES INSPECTOR.
 - (4) ALL DUCTS TO BE INSTALLED 3' FROM THE PROPERTY LINE, UNLESS OTHERWISE NOTED.
 - (5) 48" BEND RADIUS PREFERRED, 26" BEND RADIUS MINIMUM PER LES STANDARD SPECIFICATION 2225.
 - (6) WINDSTREAM AND TIME WARNER HAVE BEEN NOTIFIED OF THIS PROJECT. EXISTING CABLES FOR THE ABOVE MENTIONED UTILITIES MAY CO-EXIST IN THE TRENCH WHERE THE CABLE IS BEING LOCATED.
 - (7) CONTRACTOR TO USE APPROVED METHODS TO BACK TAMP AND RESTORE WORK AREA, FOLLOWING CITY SPECIFICATIONS WHILE IN RIGHT-OF-WAY.

REV	DESCRIPTION	DATE	BY	CHK
1				
2				
3				
4				
5				
6				
7				
8				
9				
10				
11				
12				
13				
14				
15				

NO.	DESCRIPTION	DATE	BY	CHK
1				
2				
3				
4				
5				
6				
7				
8				
9				
10				

NO.	DESCRIPTION	DATE	BY	CHK
1				
2				
3				
4				
5				
6				
7				
8				
9				
10				

NO.	DESCRIPTION	DATE	BY	CHK
1				
2				
3				
4				
5				
6				
7				
8				
9				
10				



DUCT INSTALLATION PROJECT
2017 - AREA 07
S 1ST - S 14TH ST & VAN DORN ST - PIONEERS BLVD