

Tracking No. 17070096

CONTRACT DOCUMENTS

**CITY OF LINCOLN, NEBRASKA,
LANCASTER COUNTY,
LINCOLN - LANCASTER COUNTY
PUBLIC BUILDING COMMISSION**

**Annual Supply
Workstations and Accessories
Bid No. 17-140**

**AOI
8320 Cody Dr
Lincoln, NE 68512
(402) 560-3866**

**CITY OF LINCOLN-LANCASTER COUNTY, NEBRASKA and
LINCOLN-LANCASTER COUNTY PUBLIC BUILDING COMMISSION
CONTRACT TERMS**

THIS CONTRACT, made and entered into by and between **AOI , 8320 Cody Dr, Lincoln, NE 68512**, hereinafter called "Contractor", and the City of Lincoln, Nebraska, a municipal corporation, and the County of Lancaster, Nebraska, a political subdivision of the State of Nebraska, and the Lincoln-Lancaster County Public Building Commission hereinafter called the "Owners".

WHEREAS, the Owners have caused to be prepared, in accordance with law, Specifications, Plans, and other Contract Documents for the Work herein described, and has approved and adopted said documents and has caused to be published an advertisement for and in connection with said Work, to-wit:

Workstations and Accessories, Bid No. 17-140

and,

WHEREAS, the Contractor, in response to such advertisement, has submitted to the Owners, in the manner and at the time specified, a sealed Proposal/Supplier Response in accordance with the terms of said advertisement; and,

WHEREAS, the Owners, in the manner prescribed by law has publicly opened, read aloud, examined, and canvassed the Proposals/Supplier Responses submitted in response to such advertisement, and as a result of such canvass has determined and declared the Contractor to be the lowest responsible bidder for the said Work for the sum or sums named in the Contractor's Proposal/Supplier Responses, a copy thereof being attached to and made a part of this Contract;

NOW, THEREFORE, in consideration of the sums to be paid to the Contractor and the mutual covenants herein contained, the Contractor and the Owners have agreed and hereby agree as follows:

1. The Contractor agrees to (a) furnish all tools, equipment, supplies, superintendence, transportation, and other accessories, services, and facilities; (b) furnish all materials, supplies, and equipment specified to be incorporated into and form a permanent part of the complete work; (c) provide and perform all necessary labor in a substantial and workmanlike manner and in accordance with the provisions of the Contract Documents; and (d) execute and complete all Work included in and covered by the Owners' award of this Contract to the Contractor, such award being based on the acceptance by the Owner of the Contractor's Proposal, or part thereof, as follows:

Agreement to full proposal

2. The Owners agree to pay to the Contractor for the performance of the Work embraced in this Contract, the Contractor agrees to accept as full compensation therefore, the following sums and prices for all Work covered by and included in the Contract award and designated above, payment thereof to be made in the manner provided by the Owners:

The Owners will pay for products/service, according to the Line Item pricing as listed in Contractors Proposal/Supplier Response, a copy thereof being attached to and made a part of this Contract. The Owners shall order on an as-needed basis for the duration of the contract. The cost of products or services for County agencies shall not exceed \$2,500.00 during the contract term without approval by the Board of Commissioners. The cost of products or services for City Departments shall not exceed \$5,000.00 during the contract term without approval. The cost of products or services for the Public Building Commission shall not exceed \$1,000.00 during the contract term without approval by the Board of the Public Building Commission.

3. Equal Employment Opportunity. In connection with the carrying out of this project, the contractor shall not discriminate against any employee or applicant for employment because of race, color, religion, sex, national origin, ancestry, disability, age or marital status. The Contractor will take

affirmative action to ensure that applicants are employed, and that employees are treated during employment, without regard to their race, color, religion, sex, national origin, ancestry, disability, age or marital status. Such action shall include, but not be limited to, the following: employment, upgrading, demotion or transfer; recruitment or recruitment advertising; layoff or termination; rates of pay or other compensation; and selection for training, including apprenticeship.

4. E-Verify. In accordance with Neb. Rev. Stat. 4-108 through 4-114, the contractor agrees to register with and use a federal immigration verification system, to determine the work eligibility status of new employees performing services within the state of Nebraska. A federal immigration verification system means the electronic verification of the work authorization program of the Illegal Immigration Reform and Immigrant Responsibility Act of 1996, 8 U.S.C. 1324 a, otherwise known as the E-Verify Program, or an equivalent federal program designated by the United States Department of Homeland Security or other federal agency authorized to verify the work eligibility status of a newly hired employee pursuant to the Immigration Reform and Control Act of 1986. The Contractor shall not discriminate against any employee or applicant for employment to be employed in the performance of this section pursuant to the requirements of state law and 8 U.S.C.A 1324b. The contractor shall require any subcontractor to comply with the provisions of this section.
5. Termination. This Contract may be terminated by the following:
 - 5.1) Termination for Convenience. Either party may terminate this Contract upon thirty (30) days written notice to the other party for any reason without penalty.
 - 5.2) Termination for Cause. The Owners may terminate the Contract for cause if the Contractor:
 - 5.2.1) Refuses or fails to supply the proper labor, materials and equipment necessary to provide services and/or commodities.
 - 5.2.2) Disregards Federal, State or local laws, ordinances, regulations, resolutions or orders.
 - 5.2.3) Otherwise commits a substantial breach or default of any provision of the Contract Document. In the event of a substantial breach or default the Owners will provide the Contractor written notice of said breach or default and allow the Contractor ten (10) days from the date of the written notice to cure such breach or default. If said breach or default is not cured within ten (10) days from the date of notice, then the contract shall terminate.
6. Independent Contractor. It is the express intent of the parties that this contract shall not create an employer-employee relationship. Employees of the Contractor shall not be deemed to be employees of the Owners and employees of the Owners shall not be deemed to be employees of the Contractor. The Contractor and the Owners shall be responsible to their respective employees for all salary and benefits. Neither the Contractor's employees nor the Owners' employees shall be entitled to any salary, wages, or benefits from the other party, including but not limited to overtime, vacation, retirement benefits, workers' compensation, sick leave or injury leave. Contractor shall also be responsible for maintaining workers' compensation insurance, unemployment insurance for its employees, and for payment of all federal, state, local and any other payroll taxes with respect to its employees' compensation.
7. Owner Inclusion. It is understood and agreed by all parties that "Owner/s" shall include the City of Lincoln, Lancaster County, Nebraska and Lincoln-Lancaster County Public Building Commission. Whenever in the Contract documents, including the instructions to bidders, specifications, insurance requirements, bonds, and terms and conditions or any other documents which are a part of the Contract, a singular entity is referenced (i.e., "the City" or "the County" or "Building Commission") it shall mean the "Owners" encompassing the City of Lincoln, Lancaster County and Lincoln-Lancaster County Building Commission.

8. Audit Provision: The Contractor shall be subject to an audit and shall, upon request, make available to the Public Building Commission or a contract auditor hired by the Public Service Commission, copies of all financial and performance related records and materials related to this Agreement, as allowed by law.
9. Period of Performance. This Contract shall be effective upon execution by all parties. The term of the Contract shall be a one (1) year term with the option to renew for three (3) additional one (1) year terms.
10. The Contract Documents comprise the Contract, and consist of the following:
 1. Contract Terms
 2. Accepted Proposal/Response
 3. Insurance Certificate
 4. Proprietary Information for Bids/Quotes/RFP's
 5. Specifications
 6. Instructions to Bidders
 7. Insurance Requirements
 8. Sales Tax Exemption Form 13
(Note: This form cannot be used for the WATER Division of the City of Lincoln. The WATER Division is taxable per Reg. 066.14A or applicable laws.)

The herein above mentioned Contract Documents form this Contract and are a part of the Contract as if hereto attached. Said documents which are not attached to this document may be viewed at: lincoln.ne.gov - Keyword: Bid - Awarded or Closed bids.

The Contractor and the Owners hereby agree that all the terms and conditions of this Contract shall be binding upon themselves, and their heirs, administrators, executors, legal and personal representatives, successors, and assigns.

IN WITNESS WHEREOF, the Contractor and the Owners do hereby execute this contract upon completion of signatures on:

Vendor Signature Page
City of Lincoln Signature Page
Lancaster County Signature Page
City of Lincoln-Lancaster County Public Building Commission Signature Page

Vendor Signature Page

CONTRACT
Annual Supply
Workstations and Accessories
Bid No. 17-140
City of Lincoln, Lancaster County and
City of Lincoln-Lancaster County Public Building Commission
AOI

EXECUTION BY CONTRACTOR

IF A CORPORATION:

Attest:

 Secretary Seal

AOI Corporation
 Name of Corporation

8801 S. 137th Circle
 Address Omaha, NE 68138

By: Madea Knight
 Duly Authorized Official

Vice President
 Legal Title of Official

IF OTHER TYPE OF ORGANIZATION:

 Name of Organization

 Type of Organization

 Address

By: _____
 Member

By: _____
 Member

IF AN INDIVIDUAL:

 Name

 Address

 Signature

C-17-0645

City of Lincoln Signature Page

**CONTRACT
Annual Supply
Workstations and Accessories
Bid No. 17-140
City of Lincoln, Lancaster County and
City of Lincoln-Lancaster County Public Building Commission
AOI**

EXECUTION BY THE CITY OF LINCOLN, NEBRASKA

ATTEST:

CITY OF LINCOLN, NEBRASKA

City Clerk

Finance Director

Approved by Directorial Order No. _____

dated _____

Lancaster County Signature Page

CONTRACT
Annual Supply
Workstations and Accessories
Bid No. 17-140
City of Lincoln, Lancaster County and
City of Lincoln-Lancaster County Public Building Commission
AOI

EXECUTION BY LANCASTER COUNTY, NEBRASKA

Contract Approved as to Form:

The Board of County Commissioners of
Lancaster, Nebraska

Deputy Lancaster County Attorney

dated _____

**Lincoln-Lancaster County Public Building Commission
Signature Page**

**CONTRACT
Annual Supply
Workstations and Accessories
Bid No. 17-140
City of Lincoln, Lancaster County and
City of Lincoln-Lancaster County Public Building Commission
AOI**

EXECUTION BY LINCOLN-LANCASTER COUNTY PUBLIC BUILDING COMMISSION

ATTEST:

Public Building Commission Attorney

Chairperson, Public Building Commission

dated _____

City of Lincoln/Lancaster County (Lincoln Purchasing) Supplier Response

Bid Information		Contact Information		Ship to Information
Bid Creator	Rachelle Hinze, Buyer	Address	Purchasing	Address
Email	rhinze@lincoln.ne.gov		440 S. 8th St.	
Phone	1 (402) 441-8313		Lincoln, NE 68508	
Fax	1 (402) 441-6513	Contact	Rachelle Hinze, Buyer	Contact
Bid Number	17-140	Department		Department
Title	Annual Supply - Workstations and Accessories	Building	Suite 200	Building
Bid Type	Bid	Floor/Room		Floor/Room
Issue Date	5/15/2017 09:01 AM (CT)	Telephone	1 (402) 441-8313	Telephone
Close Date	6/2/2017 12:00:00 PM (CT)	Fax	1 (402) 441-6513	Fax
		Email	rhinze@lincoln.ne.gov	Email

Supplier Information

Company AOI (AOI Corporation)
 Address 8320 Cody Dr

 Lincoln, NE 68512
 Contact Pam Leupold
 Department
 Building
 Floor/Room
 Telephone (402) 560-3866
 Fax
 Email pleupold@aoicorp.com
 Submitted 6/1/2017 01:12:27 PM (CT)
 Total \$0.00

By submitting your response, you certify that you are authorized to represent and bind your company.

Signature Ryan Stanbrough

Email rstanbrough@aoicorp.com

Supplier Notes

Lead Times are typically 5-7 weeks but may vary across the options proposed.

Bid Notes

Bid Activities

Bid Messages

Bid Attributes

Please review the following and respond where necessary

#	Name	Note	Response
1	U.S. Citizenship Attestation	<p>Is your company legally considered an Individual or Sole Proprietor: YES or NO</p> <p>As a Vendor who is legally considered an Individual or a Sole Proprietor I hereby understand and agree to comply with the requirements of the United States Citizenship Attestation Form, available at: http://www.sos.ne.gov/business/notary/citizenforminfo.html</p> <p>All awarded Vendors who are legally considered an Individual or a Sole Proprietor must complete the form and submit it with contract documents at time of execution.</p> <p>If a Vendor indicates on such attestation form that he or she is a qualified alien, the Vendor agrees to provide the US Citizenship and Immigration Services documentation required to verify the Vendor's lawful presence in the United States using the Systematic Alien Verification for Entitlements (SAVE) Program.</p> <p>Vendor further understands and agrees that lawful presence in the United States is required and the Vendor may be disqualified or the Contract terminated if such lawful presence cannot be verified as required by Neb. Rev. Stat. 4-108.</p>	No
2	Bid Documents	I acknowledge and accept that it is my responsibility as a Bidder to promptly notify the Purchasing Department Staff prior to the close of the bid of any ambiguity, inconsistency or error which I may discover upon examination of the bid documents including, but not limited to the Specifications.	Yes
3	Instructions to Bidders	I acknowledge reading and understanding the Instructions to Bidders.	Yes
4	Insurance Requirements and Endorsements	<p>Vendor agrees to provide insurance coverage for each checked box on the Insurance Clause document in the Bid Attachments including the submission of the Certificate of ACORD and the applicable endorsements:</p> <p>Insurance Certificate and required Endorsements are required at time of contract execution by the vendor.</p> <p>Vendors are strongly encouraged to send the insurance requirements and endorsement information to their insurance agent prior to bid close in order to expedite the contract execution process.</p>	Yes
5	Special Provision Term Contract Provisions	I acknowledge reading and understanding the Special Provision Term Contract Provisions.	Yes
6	Quantities	I acknowledge that the quantities listed for each line item are an estimated yearly amount. The City does not guarantee any dollar amount or order quantities for the term of the contract.	Y
7	Brochure/Specifications	I acknowledge that I have attached the brochure/specifications of the product(s) I am bidding.	Yes
8	Sample Contract	I acknowledge reading and understanding the sample contract.	Yes

9	Specifications	I acknowledge reading and understanding the specifications.	Yes
10	Term Clause of Contract	I acknowledge that the term of the contract is for a one (1) year term with the option for three (3) additional one (1) year renewals from the date of the executed contract. (a) Are your bid prices firm for the first one (1) year contract period. YES or NO (b) Are your bid prices subject to escalation/de-escalation YES or NO (c) If (b), state period for which prices will remain firm: through _____	(a) YES
11	Purchase Order, Contract and Delivery Contact	The City/County Purchasing Department issues Purchase Orders and Contracts via email to a designated contact person of the awarded Vendor. This designee will be the primary contact with the department through the delivery of the product/services. Please list the name, email address and phone number of the person who will be the contact person for the PO to be awarded.	Ryan Stanbrough, rstanbrough@aoicorp.com, 402-980-4565
12	Contract and Delivery Contact	The City/County Purchasing Department will issue a Contract via email to a designated contact person of the awarded Vendor. This designee will be the primary contact with the department through the delivery of the product/services. Please list the name, email address and phone number of the person who will be the contact person for the PO to be awarded.	Ryan Stanbrough, rstanbrough@aoicorp.com, 402-980-4565
13	Contact	Name of person submitting this bid:	Ryan Stanbrough
14	Electronic Signature	Please check here for your electronic signature.	Yes

Line Items

#	Qty	UOM	Description	Response
1	1	EA	This is to notify you that Bid 17-140 for Sit to Stand Workstations and Accessories is available. Please prepare your written response and attach your proposals as instructed in the specifications. Respond to the Attribute section (above) of this electronic bid and submit before the closing date and time. Also, you are required to enter a 0 for your response in this line item. If you have any questions, call 402-441-8313.	\$0.00

Item Notes:

Supplier Notes:

Response Total: \$0.00



Furniture Proposal

Quote Number 12249
 Project Number
 Date 06/01/2017
 Customer PO Number
 Customer Account CITLIN
 Account Manager Ryan Stanbrough
 Page 1 of 14

BILL TO
 City of Lincoln
 555 S 10 St
 AP / AR
 Lincoln, NE 68508

INSTALL AT
 City of Lincoln
 555 S 10 St
 AP / AR
 Lincoln, NE 68508

ATTN: Rachelle Hinze
 Phone: 402.441.8313
 Email: rhinze@lincoln.ne.gov

ATTN: Rachelle Hinze
 Phone: 402.441.8313
 Email: rhinze@lincoln.ne.gov

- Lines 1-5: Installation Prices for Individual Units
- Lines 6-11: Herman Miller-Height Adjustable Bases
- Lines 12-19: Herman Miller-Height Adjustable Tables
- Lines 20-23: Herman Miller-Keyboard Trays
- Lines 24-27: Herman Miller-Monitor Arms
- Lines 28-29: Herman Miller-Sit to Stand Workstations
- Lines 30-32: Herman Miller-Wall Mounted Workstations
- Lines 33-35: Herman Miller-Wrist Rests
- Lines 36-37: Humanscale-Keyboard Trays
- Lines 38-41: Humanscale-Monitor Arms
- Lines 42-44: Humanscale-Height Adjustable Bases
- Lines 45-59: Humanscale-Height Adjustable Tables
- Lines 60-64: Humanscale-Sit to Stand Workstations

Line	Quantity	Description	Unit Price	Extended Amount
1	1.00 Each	D&I-AOI Installation LABOR Labor to receive, deliver, and install 1-Height Adjustable Table	125.00	125.00
2	1.00 Each	D&I-AOI Installation LABOR Labor to receive, deliver, and install 1-Sit to Stand Workstation	125.00	125.00
3	1.00 Each	D&I-AOI Installation LABOR Labor to receive, deliver, and install 1-Monitor Arm	70.00	70.00
4	1.00 Each	D&I-AOI Installation LABOR Labor to receive, deliver, and install 1-Keyboard Tray	70.00	70.00
5	1.00 Each	D&I-AOI Installation LABOR Labor to receive, deliver, and install 1-Wall-Mounted Tech Station	125.00	125.00
6	1.00 Each	Herman Miller DU7A.E24C--NNP-SUD-G2-57 @Table Base Kit - 2 Legs, Elec. Std Range, 24D, C Foot Type NNP:@no power access SUD:@simple up down G2:@graphite satin leg with graphite satin foot	984.96	984.96

AOI

Furniture Proposal

Quote Number 12249
 Project Number
 Date 06/01/2017
 Customer PO Number
 Customer Account CITLIN
 Account Manager Ryan Stanbrough
 Page 2 of 14

		57:@glides Mark Line For: Tag L1: Hgt Adj Base		
7	1.00 Each	Herman Miller DU7A.E30C--NNP-SUD-G2-57 @Table Base Kit - 2 Legs, Elec Std Range, 30D, C Foot Type NNP:@no power access SUD:@simple up down G2:@graphite satin leg with graphite satin foot 57:@glides Mark Line For: Tag L1: Hgt Adj Base	984.96	984.96
8	1.00 Each	Herman Miller DV7AT.2448E--STS-G2-57 @Hgt Adj Base Kit w/T-Foot, Elec Std Range, 24D 48W STS:@simple up/down touch switch G2:@graphite satin leg with graphite satin foot 57:@glides Mark Line For: Tag L1: Hgt Adj Base	596.60	596.60
9	1.00 Each	Herman Miller DV7AT.2472E--STS-G2-57 @Hgt Adj Base Kit w/T-Foot, Elec Std Range, 24D 72W STS:@simple up/down touch switch G2:@graphite satin leg with graphite satin foot 57:@glides Mark Line For: Tag L1: Hgt Adj Base	619.40	619.40
10	1.00 Each	Herman Miller DV7AT.3048E--STS-G2-57 @Hgt Adj Base Kit w/T-Foot, Elec Std Range, 30D 48W STS:@simple up/down touch switch G2:@graphite satin leg with graphite satin foot 57:@glides Mark Line For: Tag L1: Hgt Adj Base	608.00	608.00
11	1.00 Each	Herman Miller DV7AT.3072E--STS-G2-57 @Hgt Adj Base Kit w/T-Foot, Elec Std Range, 30D 72W STS:@simple up/down touch switch G2:@graphite satin leg with graphite satin foot 57:@glides Mark Line For: Tag L1: Hgt Adj Base	630.80	630.80
12	1.00 Each	Herman Miller DU6ACS.2448LE--NNP-SUD-98-98-G2-PSC-NNN-57 @Renew Rect Tbl, C-Foot,Sq-Edge,Lam Top/Thermo Edge,Elec Std NNP:@no power access SUD:@simple up down 98:@studio white 98:@studio white G2:@graphite satin leg with graphite satin foot	1,058.68	1,058.68

AOI

Furniture Proposal

Quote Number 12249
 Project Number
 Date 06/01/2017
 Customer PO Number
 Customer Account CITLIN
 Account Manager Ryan Stanbrough
 Page 3 of 14

		PSC:@simple cable NNN:@no cutout 57:@glides Mark Line For: Tag L1: Hgt Adj Table		
13	1.00 Each	Herman Miller DU6ACS.2472LE--NNP-SUD-98-98-G2-PSC-NNN-57 @Renew Rect Tbl, C-Foot,Sq-Edge,Lam Top/Thermo Edge,Elec Std NNP:@no power access SUD:@simple up down 98:@studio white 98:@studio white G2:@graphite satin leg with graphite satin foot PSC:@simple cable NNN:@no cutout 57:@glides Mark Line For: Tag L1: Hgt Adj Table	1,155.20	1,155.20
14	1.00 Each	Herman Miller DU6ACS.3048LE--NNP-SUD-98-98-G2-PSC-NNN-57 @Renew Rect Tbl, C-Foot,Sq-Edge,Lam Top/Thermo Edge,Elec Std NNP:@no power access SUD:@simple up down 98:@studio white 98:@studio white G2:@graphite satin leg with graphite satin foot PSC:@simple cable NNN:@no cutout 57:@glides Mark Line For: Tag L1: Hgt Adj Table	1,111.88	1,111.88
15	1.00 Each	Herman Miller DU6ACS.3072LE--NNP-SUD-98-98-G2-PSC-NNN-57 @Renew Rect Tbl, C-Foot,Sq-Edge,Lam Top/Thermo Edge,Elec Std NNP:@no power access SUD:@simple up down 98:@studio white 98:@studio white G2:@graphite satin leg with graphite satin foot PSC:@simple cable NNN:@no cutout 57:@glides Mark Line For: Tag L1: Hgt Adj Table	1,203.08	1,203.08
16	1.00 Each	Herman Miller DV6ATS.2448LE--STS-1T-98-G2-57 @Rect Table w/T-Foot, Sq-Edge, Lam Top/TP Edge, Elec Std Ran STS:@simple up/down touch switch 1T:@pre-determined top/edge 98:@studio white G2:@graphite satin	682.10	682.10



Furniture Proposal

Quote Number 12249
 Project Number
 Date 06/01/2017
 Customer PO Number
 Customer Account CITLIN
 Account Manager Ryan Stanbrough
 Page 4 of 14

		57:@glides Mark Line For: Tag L1: Hgt Adj Table		
17	1.00 Each	Herman Miller DV6ATS.2472LE--STS-1T-98-G2-57 @Rect Table w/T-Foot, Sq-Edge, Lam Top/TP Edge, Elec Std Ran STS:@simple up/down touch switch 1T:@pre-determined top/edge 98:@studio white G2:@graphite satin 57:@glides Mark Line For: Tag L1: Hgt Adj Table	763.80	763.80
18	1.00 Each	Herman Miller DV6ATS.3048LE--STS-1T-98-G2-57 @Rect Table w/T-Foot, Sq-Edge, Lam Top/TP Edge, Elec Std Ran STS:@simple up/down touch switch 1T:@pre-determined top/edge 98:@studio white G2:@graphite satin 57:@glides Mark Line For: Tag L1: Hgt Adj Table	723.52	723.52
19	1.00 Each	Herman Miller DV6ATS.3072LE--STS-1T-98-G2-57 @Rect Table w/T-Foot, Sq-Edge, Lam Top/TP Edge, Elec Std Ran STS:@simple up/down touch switch 1T:@pre-determined top/edge 98:@studio white G2:@graphite satin 57:@glides Mark Line For: Tag L1: Hgt Adj Table	825.74	825.74
20	1.00 Each	Herman Miller Y7737.2K--0H +LS Series Keyboard Solutions, 19 Inch Track, 27" HDPE Tray 0H:+black Mark Line For: Tag L1: Keyboard Tray	199.92	199.92
21	1.00 Each	Herman Miller Y7727.1K +LT Series Keyboard Solutions, 19 Inch Track, 27W HDPE Tray Mark Line For: Tag L1: Keyboard Tray	223.38	223.38
22	1.00 Each	Herman Miller Y7724.L +LX Series Keyboard Solutions, 27W HDPE Tray Mark Line For: Tag L1: Keyboard Tray	263.16	263.16
23	1.00 Each	Herman Miller Y7741.2K--0H @TL Series Keyboard Solutions, 19 Track, 27" HDPE Tray 0H:@black	215.22	215.22

AOI

Furniture Proposal

Quote Number 12249
 Project Number
 Date 06/01/2017
 Customer PO Number
 Customer Account CITLIN
 Account Manager Ryan Stanbrough
 Page 5 of 14

24	1.00 Each	Mark Line For: Tag L1: Keyboard Tray Herman Miller Y91175.CM--0I +Flo Dual-Screen <u>Monitor Arm</u> - Surface <u>Clamp Mount</u> 0I:+silver Mark Line For: Tag L1: Monitor Arm-Dual	371.28	371.28
25	1.00 Each	Herman Miller Y91180.152CM--0I @Flo Modular <u>Monitor Arm Assembly</u> , 15-3/4H Post, 2 Arms, Surf C 0I:@silver Mark Line For: Tag L1: Monitor Arm-Dual	445.23	445.23
26	1.00 Each	Herman Miller Y91174.2CM--0I @Flo Plus <u>Monitor Arm Assembly</u> , Flo Plus Dual, Clamp Mount 0I:+silver Mark Line For: Tag L1: Monitor Arm-Dual	357.00	357.00
27	1.00 Each	Herman Miller Y91171.CM--0I +Flo <u>Single-Screen Monitor Arm Support</u> , Surf Clamp 0I:+silver Mark Line For: Tag L1: Monitor Arm-Single	183.09	183.09
28	1.00 Each	Herman Miller Y7800.1--0H @Altissimo Prime <u>Sit-to-Stand Workstation Arm</u> , Single Monito 0H:@black Mark Line For: Tag L1: Sit/Stand Workstation	469.20	469.20
29	1.00 Each	Herman Miller Y7800.2--0H @Altissimo Prime <u>Sit-to-Stand Workstation Arm</u> , Dual Monitor 0H:@black Mark Line For: Tag L1: Sit/Stand Workstation	545.70	545.70
30	1.00 Each	Herman Miller Y94004. @FX40 Compact <u>Wall-mount Technology Support</u> Mark Line For: Tag L1: Wall-Mounted Tech Station	1,174.02	1,174.02
31	1.00 Each	Herman Miller Y94009.48 @HD <u>Wall Mount Technology</u> - Slider Platform, 48" Track Mark Line For: Tag L1: Wall-Mounted Tech Station	1,667.19	1,667.19
32	1.00 Each	Herman Miller Y94015.34--0J @Mbrace <u>Wall-Mounted Technology</u> , 34 Inches Long 0J:@white Mark Line For: Tag L1: Wall-Mounted Tech Station	969.00	969.00
33	1.00	Herman Miller	26.01	26.01

AOI

Furniture Proposal

Quote Number 12249
 Project Number
 Date 06/01/2017
 Customer PO Number
 Customer Account CITLIN
 Account Manager Ryan Stanbrough
 Page 6 of 14

	Each	Y7790. +Palm Rest,Keybd Tray Mark Line For: Tag L1: Wrist Rest		
34	1.00 Each	Herman Miller Y7751. +Freestanding Palm Rest Mark Line For: Tag L1: Wrist Rest	35.70	35.70
35	1.00 Each	Herman Miller Y7792. +Palm Rest,Input Device Platform Mark Line For: Tag L1: Wrist Rest	48.45	48.45
36	1.00 Each	Humanscale Corp 6G 900 90--H-G-22 6G Black Mechanism / 900 - Std. Platform / 90 - 8.5" Clip Mo H:High Clip Mouse G:19" Gel w/ Synt. Leather Cvr 22:Std 21.625" Track Mark Line For: Tag L1: <u>Keyboard Tray</u> Tag L3: Group 1	176.70	176.70
37	1.00 Each	Humanscale Corp 6FB 500--G27-14 6FB Float Keyboard System Mechanism Black / 500 - Big Platfo G27:27" Gel w/ Lycra 14:14" Track Mark Line For: Tag L1: <u>Keyboard Tray</u> Tag L3: Group 1	140.98	140.98
38	1.00 Each	Humanscale Corp M8--C-B-1-W~----- M8 Monitor Arm C:Clamp Mount B:Black w/ Black Trim 1:Fixed Angled Link/Dynamic Link W:Long Crossbar for 2 Monitors ~:Standard 100mm x 100mm - also with 75x75 ~:Standard packaging for orders of 3 or more ---:No Selection Mark Line For: Tag L1: <u>Monitor Arm-Dual</u> Tag L3: Group 1	271.31	271.31
39	1.00 Each	Humanscale Corp MF2--2-B-2-C-12----- MFlex for M2 Arms 2:Bracket for 2 Monitors B:Black with Black Trim 2:8" Straight Link/Dynamic Link 2:8" Straight Link/Dynamic Link C:Clamp Mount	274.73	274.73

AOI

Furniture Proposal

Quote Number 12249
 Project Number
 Date 06/01/2017
 Customer PO Number
 Customer Account CITLIN
 Account Manager Ryan Stanbrough
 Page 7 of 14

		12:12"H Post (Single Row Only) -:Std 100mm x 100mm(also used for 75mm x 75mm) ~:No Post Stop -:Standard packaging for orders of 3 or more ---:No Selection Mark Line For: Tag L1: <u>Monitor Arm-Dual</u> Tag L3: Group 1		
40	1.00 Each	Humanscale Corp M2--C-B-1-S----- M2 Monitor Arm C:Clamp Mount B:Black with Black Trim 1:Fixed Angled Link/Dynamic Link S:Standard Ball Joint -:Standard 100mm x 100mm - also with 75x75 -:Standard packaging for orders of 3 or more ---:No Selection Mark Line For: Tag L1: <u>Monitor Arm-Single</u> Tag L3: Group 1	125.02	125.02
41	1.00 Each	Humanscale Corp M8--C-B-1-S~----- M8 Monitor Arm C:Clamp Mount B:Black w/ Black Trim 1:Fixed Angled Link/Dynamic Link S:Standard Ball Joint ~:Standard 100mm x 100mm - also with 75x75 ~:Standard packaging for orders of 3 or more ---:No Selection Mark Line For: Tag L1: <u>Monitor Arm-Single</u> Tag L3: Group 1	195.31	195.31
42	1.00 Each	Humanscale Corp FN--B-M-43-XXXXXXX Float Table B:Black M:Mounted 43:For 48-54" Wide x 30" Deep Tops XXXXXXXX:No Top Selection Mark Line For: Tag L1: <u>Hgt Adj Base</u> Tag L3: Group 2	949.50	949.50
43	1.00 Each	Humanscale Corp FN--B-M-63-XXXXXXX Float Table B:Black M:Mounted 63:For 60-72" Wide x 30" Deep Tops XXXXXXXX:No Top Selection	974.50	974.50



Furniture Proposal

Quote Number 12249
 Project Number
 Date 06/01/2017
 Customer PO Number
 Customer Account CITLIN
 Account Manager Ryan Stanbrough
 Page 8 of 14

		Mark Line For: Tag L1: <u>Hgt Adj Base</u> Tag L3: Group 2		
44	1.00 Each	Humanscale Corp FE--S-A-3-XXXXXXX <u>Float Electric Table</u> S:Silver A:Analog Controller 3:For 40-72" Wide x 30" Deep Tops XXXXXXX:No Top Selection Mark Line For: Tag L1: <u>Hgt Adj Base</u> Tag L3: Group 2	824.50	824.50
45	1.00 Each	Humanscale Corp FN--B-M-43-3048-BL-F <u>Float Table</u> B:Black M:Mounted 43:For 48-54" Wide x 30" Deep Tops 3048:30"D x 48"W Laminate Top BL:Black F:Flat Edge Mark Line For: Tag L1: <u>Hgt Adj Table</u> Tag L3: Group 2	1,162.00	1,162.00
46	1.00 Each	Humanscale Corp FN--B-M-43-3054-BL-F <u>Float Table</u> B:Black M:Mounted 43:For 48-54" Wide x 30" Deep Tops 3054:30"D x 54"W Laminate Top BL:Black F:Flat Edge Mark Line For: Tag L1: <u>Hgt Adj Table</u> Tag L3: Group 2	1,174.50	1,174.50
47	1.00 Each	Humanscale Corp FN--B-M-63-3060-BL-F <u>Float Table</u> B:Black M:Mounted 63:For 60-72" Wide x 30" Deep Tops 3060:30"D x 60"W Laminate Top BL:Black F:Flat Edge Mark Line For: Tag L1: <u>Hgt Adj Table</u> Tag L3: Group 2	1,212.00	1,212.00
48	1.00 Each	Humanscale Corp FN--B-M-63-3066-BL-F Float Table	1,222.00	1,222.00

AOI

Furniture Proposal

Quote Number 12249
 Project Number
 Date 06/01/2017
 Customer PO Number
 Customer Account CITLIN
 Account Manager Ryan Stanbrough
 Page 9 of 14

		B:Black M:Mounted 63:For 60-72" Wide x 30" Deep Tops 3066:30"D x 66"W Laminate Top BL:Black F:Flat Edge Mark Line For: Tag L1: <u>Hgt Adj Table</u> Tag L3: Group 2		
49	1.00 Each	Humanscale Corp FN-B-M-63-3072-BL-F Float Table B:Black M:Mounted 63:For 60-72" Wide x 30" Deep Tops 3072:30"D x 72"W Laminate Top BL:Black F:Flat Edge Mark Line For: Tag L1: <u>Hgt Adj Table</u> Tag L3: Group 2	1,242.00	1,242.00
50	1.00 Each	Humanscale Corp FE-S-A-2-E2448-BL-F Float Electric Table S:Silver A:Analog Controller 2:For 40-72" Wide x 24" Deep Tops E2448:24"D x 48"W Laminate Top BL:Black F:Flat Edge Mark Line For: Tag L1: <u>Hgt Adj Table</u> Tag L3: Group 2	1,022.00	1,022.00
51	1.00 Each	Humanscale Corp FE-S-A-2-E2454-BL-F Float Electric Table S:Silver A:Analog Controller 2:For 40-72" Wide x 24" Deep Tops E2454:24"D x 54"W Laminate Top BL:Black F:Flat Edge Mark Line For: Tag L1: <u>Hgt Adj Table</u> Tag L3: Group 2	1,037.00	1,037.00
52	1.00 Each	Humanscale Corp FE-S-A-2-E2460-BL-F Float Electric Table S:Silver A:Analog Controller 2:For 40-72" Wide x 24" Deep Tops	1,049.50	1,049.50

AOI

Furniture Proposal

Quote Number 12249
 Project Number
 Date 06/01/2017
 Customer PO Number
 Customer Account CITLIN
 Account Manager Ryan Stanbrough
 Page 10 of 14

		E2460:24"D x 60"W Laminate Top BL:Black F:Flat Edge Mark Line For: Tag L1: <u>Hgt Adj Table</u> Tag L3: Group 2		
53	1.00 Each	Humanscale Corp FE--S-A-2-E2466-BL-F Float Electric Table S:Silver A:Analog Controller 2:For 40-72" Wide x 24" Deep Tops E2466:24"D x 66"W Laminate Top BL:Black F:Flat Edge Mark Line For: Tag L1: <u>Hgt Adj Table</u> Tag L3: Group 2	1,064.50	1,064.50
54	1.00 Each	Humanscale Corp FE--S-A-2-E2472-BL-F Float Electric Table S:Silver A:Analog Controller 2:For 40-72" Wide x 24" Deep Tops E2472:24"D x 72"W Laminate Top BL:Black F:Flat Edge Mark Line For: Tag L1: <u>Hgt Adj Table</u> Tag L3: Group 2	1,079.50	1,079.50
55	1.00 Each	Humanscale Corp FE--S-A-3-E3048-BL-F Float Electric Table S:Silver A:Analog Controller 3:For 40-72" Wide x 30" Deep Tops E3048:30"D x 48"W Laminate Top BL:Black F:Flat Edge Mark Line For: Tag L1: <u>Hgt Adj Table</u> Tag L3: Group 2	1,037.00	1,037.00
56	1.00 Each	Humanscale Corp FE--S-A-3-E3054-BL-F Float Electric Table S:Silver A:Analog Controller 3:For 40-72" Wide x 30" Deep Tops E3054:30"D x 54"W Laminate Top BL:Black F:Flat Edge	1,049.50	1,049.50



Furniture Proposal

Quote Number 12249
 Project Number
 Date 06/01/2017
 Customer PO Number
 Customer Account CITLIN
 Account Manager Ryan Stanbrough
 Page 11 of 14

57	1.00 Each	Mark Line For: Tag L1: Hgt Adj Table Tag L3: Group 2 Humanscale Corp FE--S-A-3-E3060-BL-F Float Electric Table S:Silver A:Analog Controller 3:For 40-72" Wide x 30" Deep Tops E3060:30"D x 60"W Laminare Top BL:Black F:Flat Edge Mark Line For: Tag L1: <u>Hgt Adj Table</u> Tag L3: Group 2	1,062.00	1,062.00
58	1.00 Each	Humanscale Corp FE--S-A-3-E3066-BL-F Float Electric Table S:Silver A:Analog Controller 3:For 40-72" Wide x 30" Deep Tops E3066:30"D x 66"W Laminare Top BL:Black F:Flat Edge Mark Line For: Tag L1: <u>Hgt Adj Table</u> Tag L3: Group 2	1,072.00	1,072.00
59	1.00 Each	Humanscale Corp FE--S-A-3-E3072-BL-F Float Electric Table S:Silver A:Analog Controller 3:For 40-72" Wide x 30" Deep Tops E3072:30"D x 72"W Laminare Top BL:Black F:Flat Edge Mark Line For: Tag L1: <u>Hgt Adj Table</u> Tag L3: Group 2	1,092.00	1,092.00
60	1.00 Each	Humanscale Corp QS--B-H-30-F-N-N <u>QUICKSTAND BASE</u> B:Black H:Heavy Monitor Mount (Sgl Scrn) 30:30" Large Platform F:Freestanding Base N:No Cables N:No Cables Mark Line For: Tag L1: <u>Sit/Stand Workstation</u> Tag L3: Group 2	584.50	584.50
61	1.00	Humanscale Corp	609.50	609.50

AOI

Furniture Proposal

Quote Number 12249
 Project Number
 Date 06/01/2017
 Customer PO Number
 Customer Account CITLIN
 Account Manager Ryan Stanbrough
 Page 12 of 14

	Each	QS--B-C-30-F-N-N <u>QUICKSTAND BASE</u> B:Black C:Std Crossbar Monitor Mount (Dual Scrn) 30:30" Large Platform F:Freestanding Base N:No Cables N:No Cables Mark Line For: Tag L1: Sit/Stand Workstation Tag L3: Group 2		
62	1.00 Each	Humanscale Corp QS--B-W-30-F-N-N <u>QUICKSTAND BASE</u> B:Black W:Wide Crossbar Monitor Mount (Dual Scrn) 30:30" Large Platform F:Freestanding Base N:No Cables N:No Cables Mark Line For: Tag L1: Sit/Stand Workstation Tag L3: Group 2	619.50	619.50
63	1.00 Each	Humanscale Corp QSL--B-H-C <u>QUICKSTAND LITE BASE</u> B:Black H:Heavy Mount for 1 Monitor from 12-22 lbs C:Clamp Mount Mark Line For: Tag L1: Sit/Stand Workstation Tag L3: Group 2	449.50	449.50
64	1.00 Each	Humanscale Corp QSL--B-W-C <u>QUICKSTAND LITE BASE</u> B:Black W:Wide Crossbar Mount for 2 Monitors up to 27"W C:Clamp Mount Mark Line For: Tag L1: Sit/Stand Workstation Tag L3: Group 2	484.50	484.50

Order Sub-Total : \$42,914.82
Total Order : \$42,914.82

PLEASE REVIEW THIS QUOTATION AND NOTIFY US PROMPTLY OF ANY CORRECTIONS REQUIRED
 THANK YOU FOR THE OPPORTUNITY TO BE OF SERVICE
 PRICING EXPIRES 30 DAYS FROM QUOTE DATE

AOI

Furniture Proposal

Quote Number	12249
Project Number	
Date	06/01/2017
Customer PO Number	
Customer Account	CITLIN
Account Manager	Ryan Stanbrough
Page	13 of 14

All orders are subject to AOI Terms and Conditions.

Customer Signature

Date

Name

AOI

Furniture Proposal

Quote Number 12249
Project Number
Date 06/01/2017
Customer PO Number
Customer Account CITLIN
Account Manager Ryan Stanbrough
Page 14 of 14

Terms And Conditions

- Standard payment terms are Net 10 days from invoice. A 50% deposit is required on all orders.
- A 3% convenience fee will be added to invoice if a credit card is used. Credit cards will be charged in full at time of order.
- Products are made to order. AOI Corporation offers no return or restocking programs. Products may be returned only with prior written approval of AOI Corporation and the product manufacturer.
- Client changes submitted after final plan approval, and resulting in additional work, will be billed at our hourly rate, or through a mutually agreed upon addendum to the contract.
- All labor estimates have been based on AOI Corporation having clear access and use of receiving docks for product deliveries. The receiving area should be free and clear of other trades and products to prevent any delays.
- AOI Corporation will have scheduled elevator access for transporting product within the building.
- Each area in which furniture will be installed, will be substantially free and clear of other trades allowing us to stage and build product according to plan.
- Storage fees will be assessed when delays require AOI Corporation to warehouse product thirty 30 days past the scheduled installation date.
- Labor fees will be assessed when delivery address changes from the client site to an alternative receiving location.
- AOI Corporation will accept installation change requests from authorized client representatives only. Any agreed upon changes will be billed on an hourly basis, and invoiced monthly.
- Unless otherwise stated, all quoted installation work to be performed during normal business, Monday through Friday.
- Construction flaws effecting furniture installation will be reviewed as they are encountered.
- AOI Corporation is responsible for general cleaning of workstations following installation. This does not include excessive construction debris (i.e. drywall dust) resulting from construction work still in progress in the build areas.
- AOI Corporation is not responsible for product damage resulting from deliveries received directly by client representatives. AOI does not file freight claims on products drop shipped to a customer location.
- AOI may charge, and the Customer shall pay, taxes which AOI is required to collect and remit by law in connection with any sale. Customer shall pay unless AOI has received, in advance of the initial delivery, sufficient written documentation from Customer establishing exemption from such tax(es).
- Pricing expires 30 days from proposal date.
- All designs, plans, drawings, specifications, samples, and the contents there in regarding this sale shall remain the property of AOI, and may not be used, reproduced or distributed without express written permission of AOI

Herman Miller – US Communities/Installed Contract Pricing Tiers

- Height Adjustable Tables
 - Tier 1: \$1.00 - \$100,000 LIST: 62% Discount
 - Tier 2: \$100,001 - \$400,000 LIST: 64% Discount
 - Tier 3: \$400,001 – and up LIST: Negotiable
- Keyboard Trays, Monitor Arms, Sit/Stand Workstations, Wall-Mounted Technology, Wrist Rests
 - Tier 1: \$1.00 - \$100,000 LIST: 49% Discount
 - Tier 2: \$100,001 - \$400,000 LIST: 51% Discount
 - Tier 3: \$400,001 – and up LIST: Negotiable

Humanscale – Installed Pricing Tiers

- Ergonomic Tools, Keyboards, Monitor Arms, Laptop/CPU Holders, Lighting
 - Tier 1: \$1.00 - \$50,000 LIST: 62% Discount
 - Tier 2: \$50,001 - \$150,000 LIST: 64% Discount
 - Tier 3: \$150,001 – and up LIST: Negotiable
- Float, QuickStand, QuickStand Lite
 - Tier 1: \$1.00 - \$100,000 LIST: 50% Discount
 - Tier 2: \$100,001 - \$200,000 LIST: 53% Discount
 - Tier 3: \$200,001 – and up LIST: Negotiable



A warranty is a promise.

Here's ours: 12 years, 3 shifts, labor included

Our warranty covers everything—including electrical components, casters, pneumatic cylinders, tilts, and all moving mechanisms.

It recognizes the changing nature of work and the need for products that can stand up to continuous use.

And it means that when warranty work is performed in the U.S. and Canada, Herman Miller foots the bill.

At Herman Miller, we work for a better world around you. Our products—and our promise to stand behind their quality 100 percent—are designed to improve your environment whether it's an office, hospital, school, home, an entire building, or the world at large.



All products sold under the Herman Miller brand, including Herman Miller Healthcare products, Geiger products, Eames aluminum group, Eames Soft Pad group, Eames executive chairs, and Eames tables, are backed by our 12-year, 3-shift warranty, except as limited or described below. Warranty information for Nemschoff products can be found by visiting nemschoff.com/customer-service/warranty. Warranty information for Maharam textiles can be found by visiting maharam.com/site/terms.

Herman Miller Products

5 years

Herman Miller Collection products; Connect power and data; Cubert , Flute , and Tone personal task lights; Exclave whiteboards, tackboards, and accessories; Flo power hub; Formwork and Ubi liners; Logic Power Access Solutions; Mbrace wall-mounted technology; Ode lamps; Procedure/Supply Carts keyless lock bars; Twist LED task light; Ubi USB power module

3 years

Herman Miller Collection outdoor products; Compass system faucet

2 years

Magis and Mattiazzi branded products from the date of purchase by the original purchaser

1 year

Formwork stackable desktop storage; Nelson Bubble Lamps

None

Beware of imitations poster; Exclave eco boards; Girard throw; Maharam Memory 3 game; Maharam pillows; Textiles & Objects poster

Herman Miller Materials

5 years

Herman Miller proprietary fabrics applied to seating products (exceptions covered under 12-year warranty include: AireWeave 2, Balance, Bingo, Colorguard, Crepe, FLEXNET, Leather, Lyris 2, MCL Leather, Mercer, Pellicle, Rhythm, and Strata); Sayl knit back cover

1 year

Herman Miller Design on Textile (DOT) and Customer's Own Image (COI)

Parts and Components

5 years

Electronic ballasts used in task lighting; keyless lock on Compass; mechanical components (drive shaft, motor, etc.) on Locale height-adjustable surface; mechanical and electrical components on Motia sit-to-stand tables; Renew sit-to-stand pneumatic counterbalance and crank mechanism; power leg access option on Renew sit-to-stand tables

3 years

All service parts; electric motors for Co/Struc height-adjustable tables

2 years

Electrical components (switch, control box, etc.) on Locale height-adjustable surface

1 year

Compass system faucet sensors and control box

6 months

All other products, parts, and any services not listed above, sold or furnished by Herman Miller or its subsidiaries, except for consumable products such as dry-erase markers, erasers, light bulbs, fans, and other electronic products for which no warranty is given

Other Manufacturers' Products

Herman Miller does not warrant other manufacturers' product but will pass through to the original purchaser any warranty supplied by other manufacturers to the extent possible, including, but not limited to, open-line laminates.



Provisions that apply to all Herman Miller-branded products and services:

Herman Miller, Inc. ("Herman Miller"), 855 East Main Avenue, PO Box 302, Zeeland, Michigan 49464-0302, USA, warrants the products sold by it and its subsidiaries to be free from defects in material and workmanship, regardless of the number of shifts during which the products are used, for the warranty periods specified below.

This limited warranty covers the sale of Herman Miller product in all countries. Not all of the product lines appearing on this list are marketed by Herman Miller in all countries, and appearance on this list does not imply an offer for sale of a product line in a particular place. Product line availability is defined in current price lists applicable to different regions.

During the applicable warranty period, Herman Miller, as its sole obligation, will repair or replace (at its option) any product, part, or component covered by this warranty and sold after the effective date of this warranty, which fails under normal use as a result of a defect in material or workmanship. Herman Miller will repair or replace the aforementioned product, part, or component with a comparable product, part, or component.

This warranty extends only to the original purchasers who acquire new product from Herman Miller, its subsidiaries, or its authorized resellers. Any product, part, or component must have been used according to Herman Miller's published instructions and installed and maintained by a Herman Miller factory-trained technician or an authorized Herman Miller dealer installer. If these requirements are met, warranty coverage will be extended. Any misuse, abuse, or modification to the original product voids the warranty. Herman Miller does not warrant the performance of the product when used in combination with other than original Herman Miller product.

Limited warranty only covers Herman Miller provided products, components, and related repair work performed by Herman Miller authorized dealers.

The warranty period starts from the date of purchase.

This document inclusively describes all of the warranties given and remedies available with respect to the company's products and services. Herman Miller and its subsidiaries disclaim any other warranty whether express or implied, statutory or otherwise, in relation to the products.

Herman Miller does not warrant:

- natural variations in wood grain or figure or the presence of character marks
- changes in surface finishes, including colorfastness, due to aging, exposure to light or direct sunlight
- marks, scars, or wrinkles occurring naturally in leather
- veins, marks, voids, fissures, or cracks found naturally in stone
- failure resulting from normal wear and tear
- pilling of textiles
- matching of colors, grains, or textures of natural materials
- colorfastness or the matching of colors of textiles or surface finishes, including an exact match to cuttings, samples, or swatch cards

- damage, marking, or staining of veneer surfaces due to contact with rubber or similar compounds; damage from sharp objects or imprinting from writing instruments
- changes in the decibel level of motors or mechanisms utilized in height-adjustable products
- damage or marking of materials or abrading of textiles over time caused by sharp or foreign objects
- discoloration of textiles and surface materials due to soiling, stains, or dye transfer from clothing, including denim

Herman Miller tests Customer's Own Material (COM) and other customer-supplied items for manufacturing quality only and does not provide any warranty with regard to these materials.

Herman Miller does not warrant products that are exposed to extreme environmental conditions or that have been subject to improper storage.

TO THE EXTENT ALLOWED BY LAW, ANY IMPLIED WARRANTIES, INCLUDING ANY WARRANTY OF MERCHANTABILITY OR FITNESS FOR A PARTICULAR PURPOSE, ARE DISCLAIMED AND TO THE EXTENT THEY ARE LEGALLY REQUIRED, ARE LIMITED IN DURATION TO THE DURATION OF THIS WRITTEN WARRANTY.

HERMAN MILLER SHALL NOT BE LIABLE FOR LOSS OF TIME, INCONVENIENCE, COMMERCIAL LOSS, OR INCIDENTAL OR CONSEQUENTIAL DAMAGES.

Applies in US only: Some states do not allow limitations on how long an implied warranty lasts or do not allow the exclusion or limitation of incidental or consequential damages, so the limitations or exclusions in the two preceding paragraphs may not apply. This warranty gives the purchaser specific legal rights; however, the purchaser may also have other rights that may vary from state to state.

Applies outside US: Except as stated above, Herman Miller will not be liable for any loss or damage (including costs) however caused, whether direct or consequential, incurred or suffered by the purchaser or any third party in respect of the products, but nothing contained herein will or will be considered to exclude or restrict any liability on Herman Miller's part for death or personal injury resulting from negligence.

Effective May 2017

HermanMiller

For more information about our products and services or to see a list of dealers, please visit us at hermanmiller.com or call (888) 443 4357.

© 2017 Herman Miller, Inc., Zeeland, Michigan

©, Herman Miller, Bubble Lamps, Co/Struc, Eames, Flo, Formwork, Geiger, Locale, Maharam, and Pellicle are among the registered trademarks of Herman Miller, Inc., and its owned subsidiaries.

*** AireWeave, Compass, Connect, Cubert, D01, Eames Soft Pad, Exclave, FLEXNET, Flute, Lyris 2, Motia, Nelson, Ode, Renew, Sayi, Tone, Twist, and Ubi are among the trademarks of Herman Miller, Inc., and its owned subsidiaries.

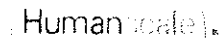
[Search](#)
[Home](#) | [Shop](#) | [Catalog](#) | [Ergonomics](#) | [Seating](#) | [Tables](#) | [Chairs](#) | [About Us](#) | [Contact Us](#) | [Privacy Policy](#)

[PRODUCTS](#)
[ERGONOMICS](#)
[RESOURCES](#)
[ABOUT](#)
[HEALTHCARE](#)
[About](#) | [Legal Information](#)

Humanscale's Terms & Conditions

THE FOLLOWING TERMS & CONDITIONS APPLY TO ALL HUMANSCALE PRODUCTS OTHER THAN HUMANSCALE HEALTHCARE PRODUCTS

THE TERMS & CONDITIONS FOR HUMANSCALE HEALTHCARE PRODUCTS ARE PROVIDED [HERE](#).

TERMS OF PAYMENT

Upon approved credit, terms of payment are net 30 from date of shipment. Deposits may be required for large or custom orders. The processing of orders under shipment of orders placed may be delayed if the deposit is not received with the order or if customer's account is in "Past Due" status.

CREDIT POLICY

All customers of Humanscale must complete a credit application, with current information, which must be signed by an owner or officer. A line of credit may be set by our Credit Department, however the basis for the line of credit may be changed or cancelled at our discretion and advance payment may be required. Any unpaid balance, upon which payments are not made according to the terms governing the sale, will be considered "Past Due" and will increase by a maximum of 2% per month, without forfeit of Humanscale's right to payment.

Any customer who has failed to pay for goods delivered or services rendered in a timely manner shall be liable for all fees, expenses, disbursements, and charges, (including all legal costs) incurred by Humanscale in collecting monies owed, as well as interest (at 24% per annum).

PURCHASE ORDERS

Purchase orders must include the following "Bill To" and "Ship To" information—Company Name (Ship To company may be end user or installation company), Address, Telephone, Fax, Contact Person, End User Company Name, Requested Ship Date, Purchase Order Number, Special Delivery Shipping and Packing Instructions (if applicable), Proper Discount Off Current List Price, Product Quantities and Full Model Numbers, and Total (List Net).

ORDER CHANGES AND CANCELLATIONS

All changes to or cancellations of orders placed with Humanscale must be in writing and sent to Humanscale Customer Service. All changes to or cancellations of Quick Ship orders will incur a minimum change/cancellation fee of 10% of net. All other orders may be changed or cancelled without penalty if Humanscale is notified at least two (2) weeks before the scheduled ship date for standard orders (under 250 units), or at least three (3) weeks before the scheduled ship date for large orders (250 units or more). Order changes or cancellations made less than two (2) weeks before the scheduled ship date for standard orders or less than three (3) weeks before the scheduled ship date for large orders will incur a minimum change/cancellation fee of 10% of net. Irrespective of when notified, changes or cancellations are not binding upon Humanscale until Humanscale issues a written acknowledgment of the change or cancellation. Order changes are defined as the deletion of line items, changes in style, color, quantity or requested ship date, or ship-to address changes. Order changes that result in a quantity reduction may be subject to an additional small order fee or adjustment in pricing. Under no circumstances will changes or cancellations be accepted on any custom fabric, special order or custom product orders.

TAXES

Humanscale list prices do not include sales tax. Customer is responsible to remit all such tax. Humanscale requires a State Resale/Exemption Certificate to be on file at its main office. Sales made without said Certificate will be charged the appropriate sales tax.

PRICES

All discounts and list prices are subject to change without notice. Prices are those in effect at the time of order entry. If the requested shipment date is more than 90 days after the order date, Humanscale reserves the right to price said order based on the published list price as of the shipment date.

SMALL ORDER FEE

A 3% small order fee applies to all invoiceable orders of \$1,500 net or less, including billable replacement parts, regardless of product category. This small order fee does not apply to orders made through quickstand.humanscale.com or www.humanscale.com.

SHIPPING AND DELIVERY

All Humanscale orders are acknowledged with a promise date (scheduled ship date) based on the product with the longest lead time. Large orders may increase standard lead times. Standard shipping charges will be billed to customer. Custom platform orders require 4 to 6 weeks.

Quick Ship seating orders for up to 50 chairs will ship within 10 business days from the date of order entry as long as Quick Ship was specified on the order. Seating orders for up to 150 chairs will ship within four weeks from the date of order entry for chairs containing any combination of Wave, Zellan, Manufacture Stripe, Posture and Dash fabrics. Seating orders for up to 100 chairs will ship within six weeks from the date of order entry for

of other fabric. Consult with your Humanscale representative for lead times on all other seating orders. Unless otherwise contractually specified, Diffiant Vero, Freedom and Liberty chairs will ship with the base and frame disassembled. Chairs can be easily assembled in seconds without use of tools. Blanket-wrapped shipping is available for full truckloads of 200 or more Diffiant Vero, Freedom or Liberty Task and Conference chairs. Consult your Humanscale representative for blanket-wrapped shipping requirements for Canto and the Liberty Side chair.

Ship Sets:

All products ordered on a single purchase order will be delivered together in a single ship set. To treat a ship set, customers must indicate "Ship as Available" on the purchase order. Upon request, customer accounts may be defaulted to ship all orders on an as available basis.

Shipping Instructions:

Humanscale will attempt to accommodate basic shipping instructions, such as "call ahead" or "deliver before 12:00 pm," if clearly identified in the purchase order as "Shipping Instructions."

Packing Instructions:

Humanscale will attempt to accommodate basic packing instructions for internal delivery of specific items on an order, such as "Deliver to Joe Smith" or "Deliver to cube #218," if clearly identified on the purchase order as "Packing Instructions."

DELIVERY SHORTAGES

Product shortages must be noted at the time of delivery and reported to the carrier for correction. Claims against Humanscale for shortages, errors, etc., must be made in writing and within three (3) days of the date of delivery or customer waives its right to make such a claim.

FREIGHT CLAIMS

Humanscale will file all F.O.B. destination claims. In order to receive credit, customer agrees to cooperate and assist in the procedures set out by the carrier and Humanscale.

EXTERNAL DAMAGE

If the shipping container shows any external damage, customer is instructed to refuse the product at time of delivery. If it is a multiple piece shipment, customer may refuse only the damaged items. Humanscale will not issue full credit for returned product unless customer takes the following action steps:

1. Note damage on the delivery receipt at time of delivery.
2. Refuse product at time of delivery.
3. Contact Humanscale Customer Service within 24 hours of the attempted delivery and advise them of the damage.
4. Enter a chargeable replacement order; credit will be issued after the disposition of damaged product is determined.

CONCEALED DAMAGE/LOSS

If customer determines that there is internal damage not visible at time of delivery, customer will retain all packaging materials and take the following action steps within fifteen (15) calendar days from the date of delivery:

1. Request inspection by calling local freight carrier to report damage.
2. Retain merchandise in the original box.
3. Call your Humanscale Customer Service agent to provide order and product information.
4. Get a copy of the inspection report from carrier.
5. Enter a chargeable replacement order; credit will be issued after the disposition of damaged product is determined.

STORAGE

If a customer is unable to accept a scheduled product delivery, Humanscale, if notified in writing after product assembly and prior to the scheduled ship date, will store the product at customer's expense. Humanscale shall invoice customer for the product and monthly Storage Fees.

Storage Fees will be 1% of the net order value per month or actual storage costs—whichever is greater. Storage Fees are calculated with a one-month minimum and will not be pro-rated. If customer is unable to accept a scheduled product upon delivery, customer shall be responsible for placing the product in storage and bears the risk of loss. However, payment of the balance due is per Humanscale's Terms of Payment.

RETURN AUTHORIZATIONS and REFUSALS

All returned and non-damaged refused orders are subject to a five percent (5%) restocking fee. Seating and special order returns will not be accepted. Customer must request a Return Authorization through the Humanscale Customer Service Department within 45 days of product receipt to return any product. If Humanscale agrees to restock the product, customer must return it freight prepaid to Humanscale, F.O.B., to the original shipping point or as otherwise instructed by Humanscale Customer Service. If product is returned without a Return Authorization, Humanscale will notify customer of the unauthorized return and customer must provide instructions for its disposition within one week thereafter. Failure of customer to respond within one week will result in Humanscale's right to dispose of the product with no credit. Return Authorizations expire sixty (60) days after the date of issue. If the returned product is not in resalable condition, customer will not receive credit for the return. Customer must promptly provide a purchase order or other acceptance of fees/credit reduction as required.

RETURN AUTHORIZATIONS and REFUSALS - TECHNOLOGY PRODUCTS

All returned and non-damaged refused orders are subject to a thirty percent (30%) restocking fee. Special order returns will not be accepted. Customer must request a Return Authorization through the Humanscale Customer Service Department within 15 days of product receipt to return any product. If Humanscale agrees to restock the product, customer must return it (freight prepaid to Humanscale, F.O.B.), to the original shipping point or as otherwise instructed by Humanscale Customer Service. If product is returned without a Return Authorization, Humanscale will notify customer of the unauthorized return and customer must provide instructions for its disposition within one week thereafter. Failure of customer to respond within one week will result in Humanscale's right to dispose of the product with no credit. Return Authorizations expire sixty (60) days after the date of issue. If the returned product is not in resalable condition, customer will not receive credit for the return. Customer must promptly provide an unaltered order or call for a replacement of fees/credit reduction as required.

LIMITED WARRANTY

Humanscale offers the following warranty on its products, subject to any exclusions and limitations as set forth below:

Product	Warranty
Customer's Own Material (COM, COL)	No Warranty
Switch Mouse	1 Year, 24/7 Warranty
Technology Products	3 Years, Limited Warranty
Floform Series Lights	10 Years, 24/7 Warranty
Horizon Series Lights	10 Years, 24/7 Warranty
Bifluent Series Lights	5 Years, 24/7 Warranty
Float Table, (Mechanical)*	5 Years, 24/7 Warranty
eFloat and Electric Float***	5 Years, 24/7 Warranty
Desk Stand Sit/Stand Workstation	5 Years, 24/7 Warranty
Desk Stand Lite	5 Years, 24/7 Warranty
Fabric/Cushions/Arm Pads	5 Years, Single-Shift Warranty
M2, M7 & M8 Monitor Arms	15 Years, 24/7 Warranty
M4, M7 & M8 Monitor Arms with Gas Cylinder Components	10 Years, 24/7 Warranty
Ballo Stool**	3 Years, Single-Shift Warranty
Vessel Lights†	10 Years, 24/7 Warranty, 3 Years 24/7 Warranty for the power supply driver
All other seating and products detailed in a current Humanscale Price Guide, unless otherwise specified	15 Years, 24/7 Warranty
All other products (eGT) detailed in a current Humanscale Price Guide	Varies, consult your Humanscale representative for details

* Modifying or tampering with any part of the base of the Float Table will render the warranty void. The warranty on the Float Table applies to the base and work surface if the table top is provided by Humanscale, and only to base if the table top is provided by a third party, provided that the third party table top meets the following requirements: (i) has a depth of 36" or less, (ii) has a width of 72" or less, and (iii) the total weight load including work surface is no more than 130 lbs for the standard base and no more than 160 lbs for the heavy duty base.

** Note: Ballo is not a task chair. It has not passed the BIFMA or European EN standards for office seating. The Ballo is an exercise chair that is designed for dynamic seating and frequent movement. All Ballo instructions should be followed to ensure a comfortable experience.

*** Modifying or tampering with any part of the base of the eFloat or electric Float will render the warranty void. The warranty on the eFloat and electric Float applies to the base and work surface if the table top is provided by Humanscale, and only to base if the table top is provided by a third party, provided that the third party table top meets the following requirements: (i) has a depth of 36" or less, (ii) has a width of 72" or less, and (iii) a total weight load including work surface of no more than 200 lbs.

† The warranties for the Vessel lights exclude labor and other costs associated with the installation and/or removal of the lights from ceilings, walls, fixtures, etc. Further, Humanscale has no warranty obligations if the product is affected by internal or external environmental conditions (including but not limited to water, moisture, outdoor use, or temperature damage), power fluctuations, improper power supply, or if the product is not installed and used in compliance with all applicable standards and electrical codes.

These warranties are available to the original end user customer only and are non-transferable. For these warranties to be valid, the Humanscale product must have been purchased directly from Humanscale and/or an authorized dealership, distributor, retailer and/or reseller of Humanscale products. If products are procured through an authorized dealership, distributor, retailer and/or reseller, the end-user customer must be registered with Humanscale for the warranty to be in effect. Humanscale warrants that, at the time of customer's receipt, the product will be in good working order and will be free from defects in materials and workmanship for the duration of the warranty term, as set forth above. These warranties do not apply to normal wear and tear or damage caused by accident, neglect, product abuse, misuse and/or failure to follow instructions relating to the product's installation or intended use. Humanscale will not be responsible for damage due to service, maintenance, modifications or tampering by anyone other than a Humanscale authorized representative. Humanscale will not be responsible for injury or damage caused by or associated with the installation and/or use of products in any manner other than in strict conformance with the instructions set forth in its installation manuals and instruction sheets and/or product literature. These warranties do not cover damage caused by a carrier or transporter, of the product from one location to another, or alterations made by owner. Humanscale does not warrant damages or defects to the products under the following conditions: an Act of God, damage from electrical power problems, usage of parts or components not supplied by Humanscale, failure to perform (preventive) maintenance, or damage caused by peripherals not supplied by Humanscale.

In the event a product or product part is defective in material or workmanship during the warranty period, and Humanscale receives written notice of the defect within the warranty period, Humanscale will determine with customer if the defect is covered under warranty. Humanscale, at its option, may repair or replace the defective product or product part determined to be under warranty with the same or comparable product or product part as determined by Humanscale, at customer's location or at a designated Humanscale location. The labor costs associated with the repair of the product or product part may be the responsibility of Humanscale if the product or product part is determined to be under warranty. Humanscale must pre-approve the labor costs prior to the repair or replacement of warranty products or product parts. Customer must contact Humanscale to obtain a Return Authorization through the Humanscale Customer Service Department. Performance of any repair or replacement does not renew or extend the warranty period. If, after examining and testing a returned product or product part, Humanscale determines that the product or product part is not defective, Humanscale will notify customer and return the product or product part to customer. Customer will be responsible for the freight charges associated with the return of non-defective products or product parts. To return a product or product part for repair that is not covered by warranty, Customer must request a Return Authorization through the Humanscale Customer Service Department. Customer will bear the costs of labor and freight charges associated with non-warranty repair. Customer will be charged a standard repair fee, specific to the product, for any product that is repaired outside of the warranty period. Repairs of products out of warranty also carry a 90 day warranty, effective the day that Customer receives the repaired product or product part. For products that are not covered under warranty, Customer may upgrade to a newer, functionally equivalent product at the list price, the product or product part will be returned to Customer, or Customer can request in writing that Humanscale dispose of the product or product part for Customer, in which case a fee may apply as designated by local law.

DISCLAIMER

THIS LIMITED WARRANTY IS IN LIEU OF ALL OTHER REPRESENTATIONS, WARRANTIES OR CONDITIONS, EXPRESS OR IMPLIED, INCLUDING, BUT NOT LIMITED TO, ANY IMPLIED REPRESENTATIONS, WARRANTIES OR CONDITIONS OF MERCHANTABILITY, FITNESS FOR A PARTICULAR PURPOSE, NON-INFRINGEMENT, NON-INTERFERENCE, AND ALL OTHER WARRANTIES ARISING FROM COURSE OF DEALING OR USAGE OF TRADE.

Humanscale does not warrant that customer's use of the Humanscale product will be uninterrupted or error free. Any implied warranties that may be imposed by law are limited in duration to the Limited Warranty period, to the greatest extent allowed by law. Some states or countries do not allow a limitation on how long an implied warranty lasts or the exclusion or limitation of incidental or consequential damages for consumer products. In such states or countries, some exclusions or limitations of this Limited Warranty may not apply. This Limited Warranty is subject to change without notification.

LIMITATION OF LIABILITY

Purchaser's remedies set forth herein are exclusive and the liability of Humanscale with respect to the breach of this agreement or any contract entered into between the parties pursuant hereto shall not exceed the price of the product or part on which such liability is based. In no event will Humanscale be liable to purchasers for any special, collateral, incidental or consequential damages however caused, whether by Humanscale's negligence or otherwise. The remedies provided above are the purchaser's sole remedies for any failure of Humanscale to comply with its obligations regarding the workmanship of its products. Correction of any nonconformity in the manner and for the period of time provided shall constitute complete fulfillment of all liabilities of Humanscale, with respect to or arising out of the product furnished hereunder.



ESSENTIAL WORK STATION

- [Home](#)
- [About Us](#)
- [Careers](#)
- [Contact Us](#)

ERGONOMICAL ACCESSORIES

- [Chairs](#)
- [Mice](#)
- [Keyboards](#)
- [Mouse Pads](#)
- [Mouse](#)
- [Webcams](#)

ERGONOMICAL CONSULTING SERVICES

WHAT IS HUMANSCALE?
ERGONOMICAL SOLUTIONS

DESIGNER TOOLKIT
DOWNLOAD LIBRARY
WATCH, LISTEN & LEARN

COMPANY OVERVIEW
CORPORATE SOCIAL RESPONSIBILITY
DESIGN STUDIO
WHERE TO BUY
CUSTOMER PARTNERS
TRAINING
LEGAL INFORMATION

HEALTHY LIFE PRINCIPLES
HEALTHY LIFE RESOURCE
DESIGN PRINCIPLES
ABOUT HUMANSCALE
HEALTHY LIFE
WORKING WITH US
CONTACT

HermanMiller
Renew™ Sit-to-Stand Tables

Lines 6 & 7, 12 – 15
of AOI Proposal



Good for your body,
your mind, and your work

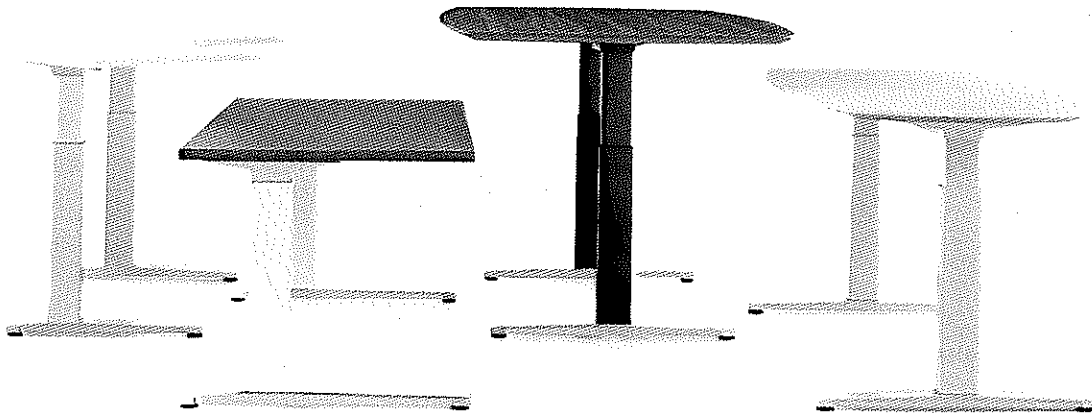

Renew Sit-to-Stand Tables
Designed by Brian Alexander

While your brain is busy solving problems and coming up with new ideas, the rest of your body is hard at work, too—pumping blood, keeping oxygen flowing, holding up your head, and signaling your brain when it wants to move. A common and advisable response is to switch postures between sitting and standing throughout the day. The right work tools can make this transition as natural and seamless as possible.

Supporting your body as you move is a concept we defined and designed into every one of our work chairs. Renew Sit-to-Stand Tables take healthful movement to a new level. By allowing you to seamlessly transition between seated and standing working postures, Renew can help you stay more active and healthier while you work. Frequently changing postures helps reduce the physical stresses that put you at risk for aches and pains so you can keep up a steady flow of energy and ideas.



A variety of privacy screens can be added to Renew to give people a sense of enclosure and ownership over their personal space when using the table in group settings.

A Natural Part of Your Day

Renew works in all the same places you do. Use it in a private office, a home office, or collaborative spaces. Integrate it into systems furniture, in an open office environment, or use it on its own, with or without optional attachable privacy screens. It even works in a conference room, giving you the freedom to hold efficient stand-up meetings or stay fresh by making healthy movement a part of your agenda.

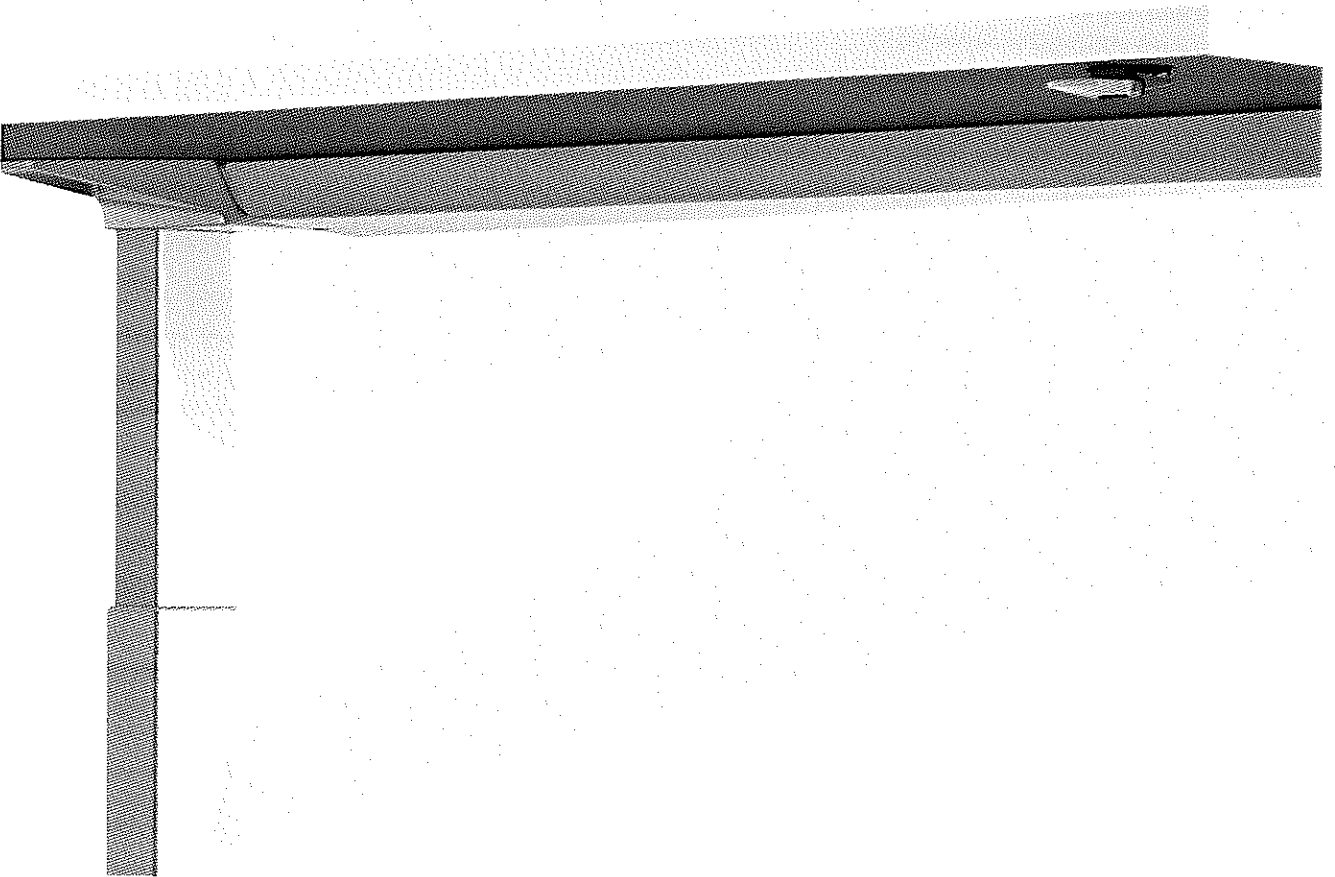

Renew keeps all electrical components concealed neatly below the surface. The softly angled corners are also easy on your knees.

The simple, intuitive control works exactly as you'd expect: Lift up to raise the table, press down to lower it.



Renew can become a centerpiece of settings designed to support team collaboration. Raising the table to standing height encourages participation in whiteboard exercises.

Shaped Around the Way You Work

Every inch of Renew was thoughtfully considered from your point of view—and that of the person sitting or standing next to you. Its top-to-bottom human-centered design features softly angled corners to prevent bumps and bruises. With slim-profile legs mounted flush to the outside of the surface, you'll also find more room for knees under the table.

About Brian Alexander

Brian Alexander describes himself as an observationalist. "I spend a lot of time getting to know the behaviors of everything," he says. He is so fascinated by people's behavior, in fact, that he's been compiling an owner's manual for humans since the late 1980s. He adds to the manual frequently—and draws upon it for every project he does. One example is the intuitive height-adjustment switch on Renew Sit-to-Stand Tables. After noting how people interacted with other switches, he designed a new control that encompasses our basic intuitions about direction.



Brian Alexander

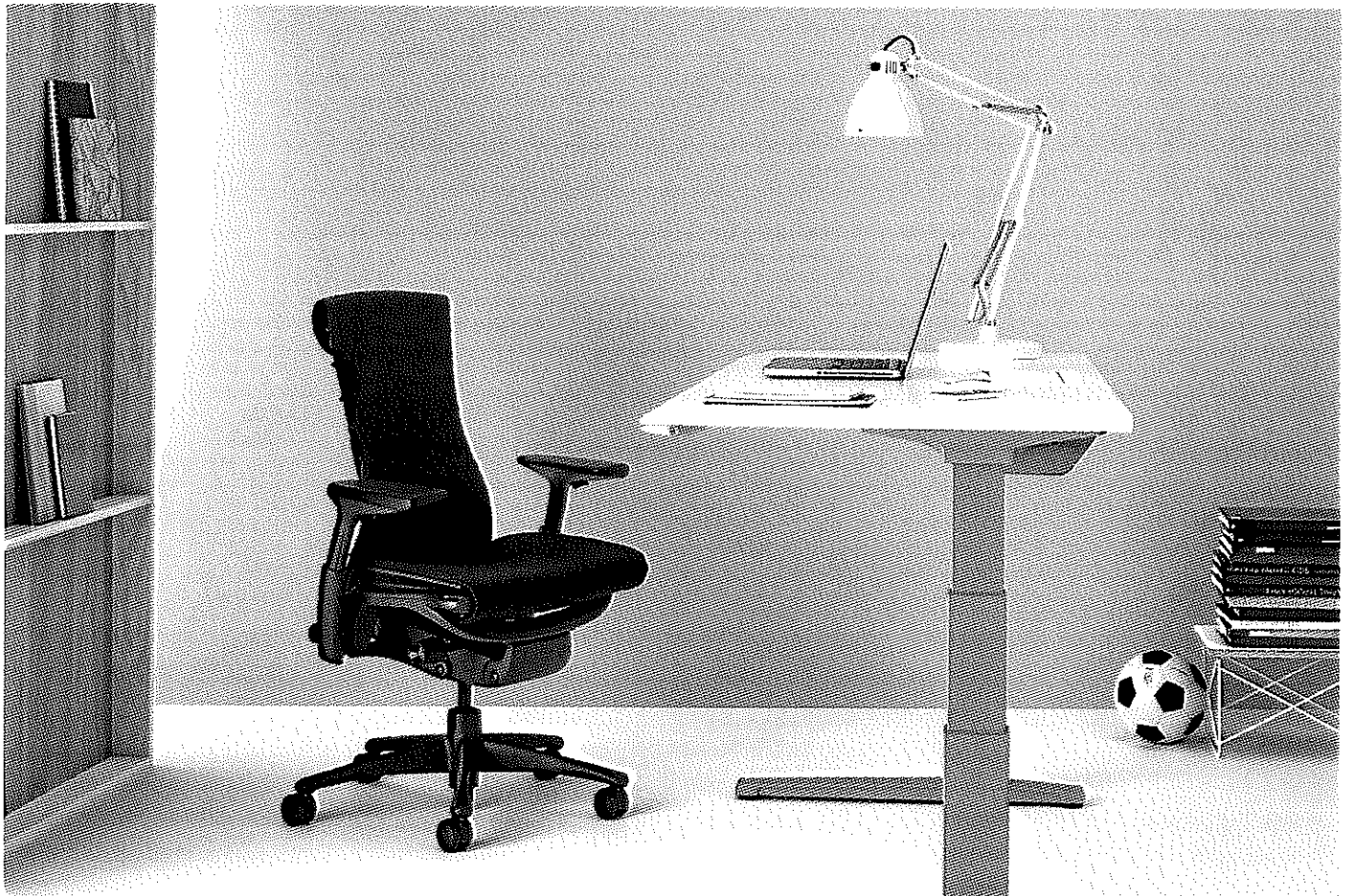

A seamless wire management design routes the cords from all of your desktop tools into a high-density cable trough below the table, keeping them out of sight even when the table is raised. Power can even be passed through the base for a clean, streamlined aesthetic.

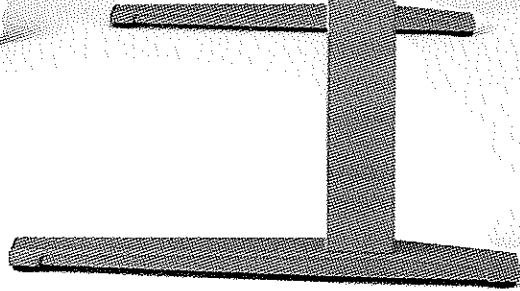

Components

The variety of surface shapes available is sized to integrate with common workspace configurations.



Rectangular Table with C-Foot



Rectangular Table with T-Foot

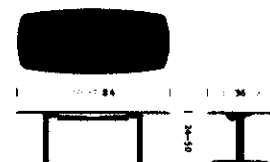

Oval Table with T-Foot

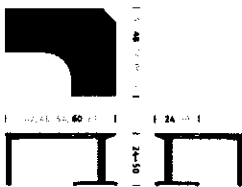

90° Extended Corner Table with C-Foot

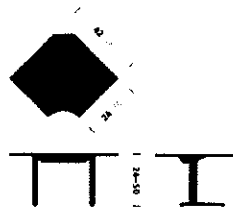

90° Corner Table with C-Foot

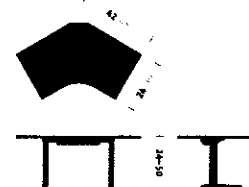

120° Corner Table with C-Foot

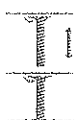

Mechanism

- Electric Standard (E)
- Electric Extended (D)
- Crank Sit-to-Stand (C)
- Crank Seated (K)
- Pneumatic Counterbalance

Sit-to-Stand Height Range









- 27" to 46"
- 22" to 48"
- 27" to 46"
- 22" to 34"
- 27" to 46"

Materials





Visit hermanmiller.com/materials to see representational samples of our complete textile and materials offering.





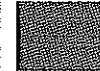

Renew Sit-to-Stand Tables

Top Formcoat[®]







								
White 91	Soft White LU	Sandstone WL	Warm Grey Neutral WN	Folkstone Grey BQ	Cool Grey Neutral CL	Natural Maple Fleck 7F	Light Anigre Fleck 7G	Aged Cherry Fleck 7H

Patterned Laminate





				
Crisp Linen LBM	Classic Linen LBN	Casual Linen LBP	Powder Mesh LBK	Steel Mesh LBL

						
White Twill LBQ	Neutral Twill LBF	Savum Twill LBG	Earthen Twill LBH	Graphite Twill LBI	Canyon Zephyr 28/D1	Mistred Zephyr 29/DC









Solid Laminate

						
White 91	Soft White LU	Sandstone WL	Inner Tone Light HF	Warm Grey Neutral WN	Folkstone Grey BQ	Cool Grey Neutral CL







Woodgrain Laminate





				
Natural Maple HM	Light Anigre HP	Aged Cherry HX	Light Brown Walnut 76	Walnut on Cherry HY

Wood & Veneer

								
Clear on Ash ET	Natural Maple UL	Oak on Ash EU	Aged Cherry ED	Light Brown Walnut 2U	Walnut on Cherry UX	Medium Red Walnut EK	Walnut on Ash EV	Dark Brown Walnut 40

Base Finish

						
Metallic Silver MS	Warm Grey Neutral WN	White 91	Studio White 98	Sandstone WL	Folkstone Grey BQ	Graphite Satin G2

			
Metallic Silver Polished Aluminium LFI	Warm Grey Neutral Polished Aluminium LFG	White Polished Aluminium LFF	Graphite Satin Polished Aluminium LFH

For more information, please visit hermanmiller.com or call 888 443 4357.

HermanMiller, , and Formcoat are among the registered trademarks of Herman Miller, Inc. Renew is among the registered trademarks of Herman Miller, Inc.

Printed in the USA. Please recycle.
© 2016 Herman Miller, Inc., Zeeland, Michigan O.DU202
All rights reserved.

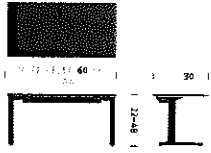

Rectangular Table with C-Foot

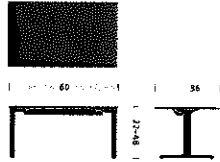

Rectangular Table with T-Foot

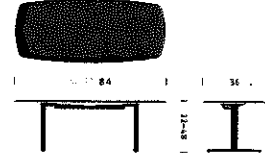

Oval Table with T-Foot

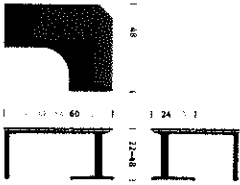

90° Extended Corner Table with C-Foot

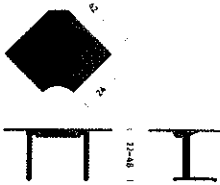

90° Corner Table with C-Foot

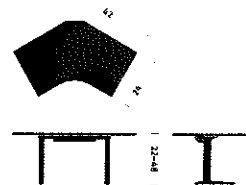

120° Corner Table with C-Foot



- Mechanism**
- Electric Standard (E)
 - Electric Extended (D)
 - Crank Sit-to-Stand (C)
 - Crank Seated (K)
 - Pneumatic Counterbalance

- Sit-to-Stand Height Range**
- 27" to 46"
 - 22" to 48"
 - 27" to 46"
 - 22" to 34"
 - 27" to 46"



[Where to Buy](#) [Newsletters](#) [Contact](#) [Customer Service](#) [Search](#)

[PRODUCTS](#) [DESIGN RESOURCES](#) [RESEARCH](#) [WHY MAGAZINE](#) [ABOUT US](#) [STORE](#)

[Design Resources](#) [3D Models / Revit](#) [3D Models by Product](#) [Tables](#) [Sit-to-Stand Tables](#)

3D Models / Revit

3D Models by Product

[Seating](#)

[Workspaces](#)

Tables

[Conference Tables](#)

[Sit-to-Stand Tables](#)

[Training Tables](#)

[Dining Tables](#)

[Occasional Tables](#)

[Storage](#)

[Accessories](#)

[Revit Families and Typicals](#)

[AutoCAD Symbols](#)

[Z-Viewer](#)

[3D File Format](#)

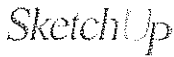

Looking for SketchUp Files?

Download AutoCAD DWG files from the 3D Models page or Save DWG from CAD Pack and import into SketchUp using the scale units of inches

SIT-TO-STAND TABLES

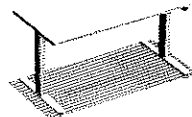

Motia Table 30D 60W

3ds Max file (14 KB)
AutoCAD 3D file (78 KB)
SketchUp file (943 KB)
Revit file (822 KB)

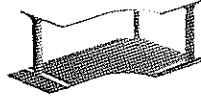

Renew Sit-to-Stand 90°
Extended Corner Table C-Foot
30D 72W 48W

3ds Max file (37 KB)
AutoCAD 3D file (250 KB)
SketchUp file (1558 KB)
Revit file (827 KB)

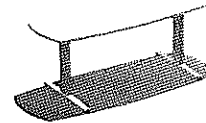

Renew Sit-to-Stand Oval T-Foot
Table 30D 72W

3ds Max file (25 KB)
AutoCAD 3D file (175 KB)
SketchUp file (1265 KB)
Revit file (691 KB)

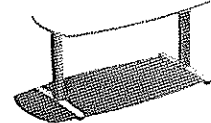

Renew Sit-to-Stand Oval Table
T-Foot 30D 60W

3ds Max file (25 KB)
AutoCAD 3D file (175 KB)
SketchUp file (1265 KB)
Revit file (691 KB)

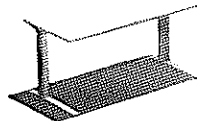

Renew Sit-to-Stand
Rectangular Table C-Foot 30D
60W

3ds Max file (24 KB)
AutoCAD 3D file (171 KB)
SketchUp file (1246 KB)
Revit file (671 KB)

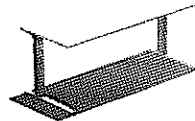

Renew Sit-to-Stand
Rectangular Table C-Foot 30D
72W

3ds Max file (24 KB)
AutoCAD 3D file (171 KB)
SketchUp file (1246 KB)
Revit file (671 KB)

[Site Map](#) [Legal](#) [Terms of Use](#) [Privacy](#) [Site Feedback](#) | [Other Sites](#) [United States](#)

© 2017 Herman Miller, Inc

HermanMiller
Mofa Sit-to-Stand Tables

Lines 8 - 11, 16 - 19
of AOI Proposal



Elevate your work experience



Motia Sit-to-Stand Tables

In an ongoing effort to promote wellness in the workplace, the Motia Sit-to-Stand Table puts people and workplaces in motion. Moving with workers and their workflow, Motia enables a smooth transition between sitting and standing. Designed with quality, minimal materials, and available in various finishes, Motia makes height adjustability easy to afford, easy to use, and easy to integrate—in any setting.

Ergonomically, Motia works with performance seating and technology support such as monitor arms to provide a range of healthy postures at various heights. Privacy screens can be added to give people a sense of solitude within open environments.

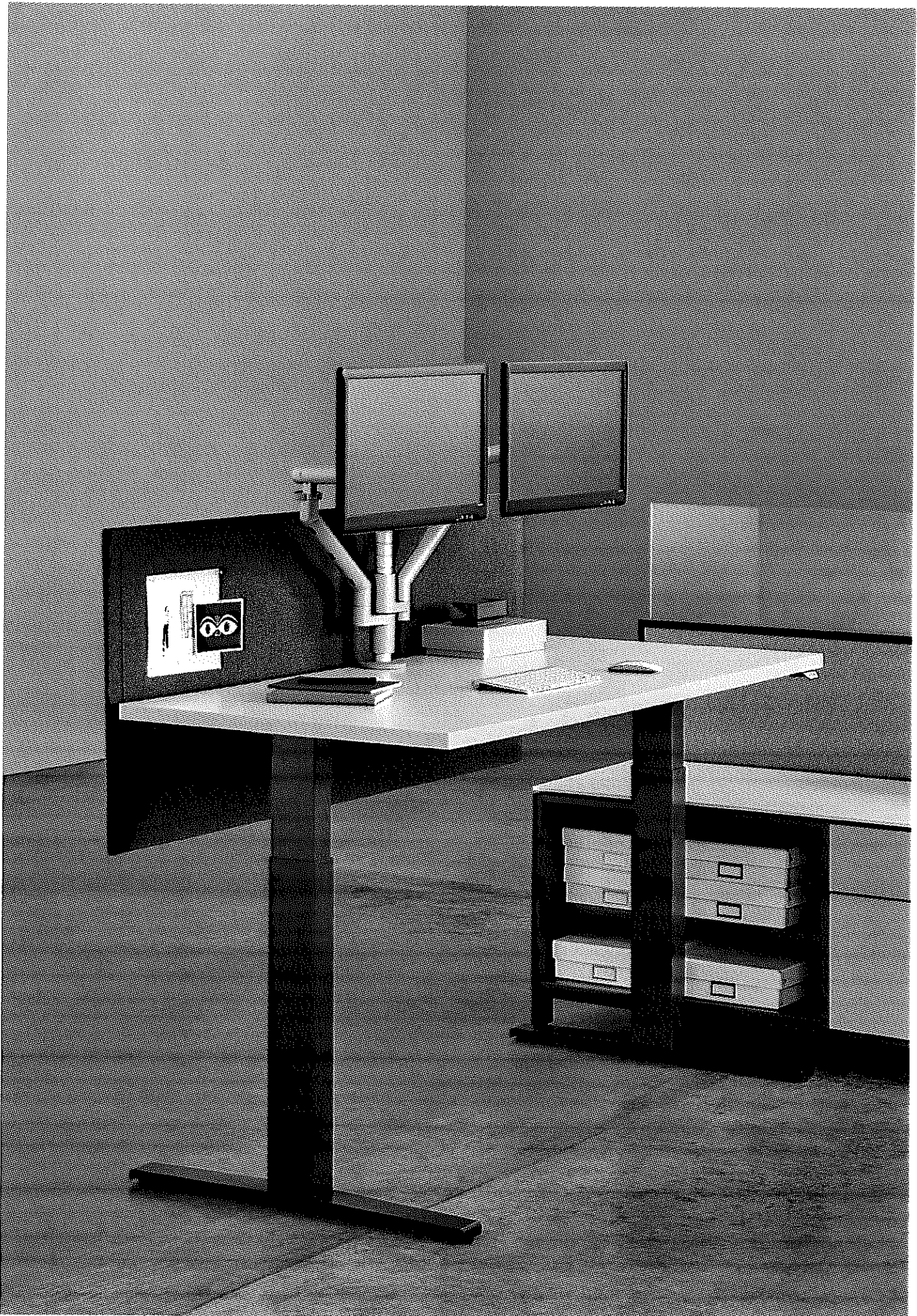

Promote Wellness at Work

It's commonly known that a sedentary lifestyle can cause a higher risk of health problems. However, most of us are motionless about 21 hours a day, between sitting and sleeping. The Motia Sit-to-Stand Table makes it easier to move throughout the workday—keeping bodies healthier.

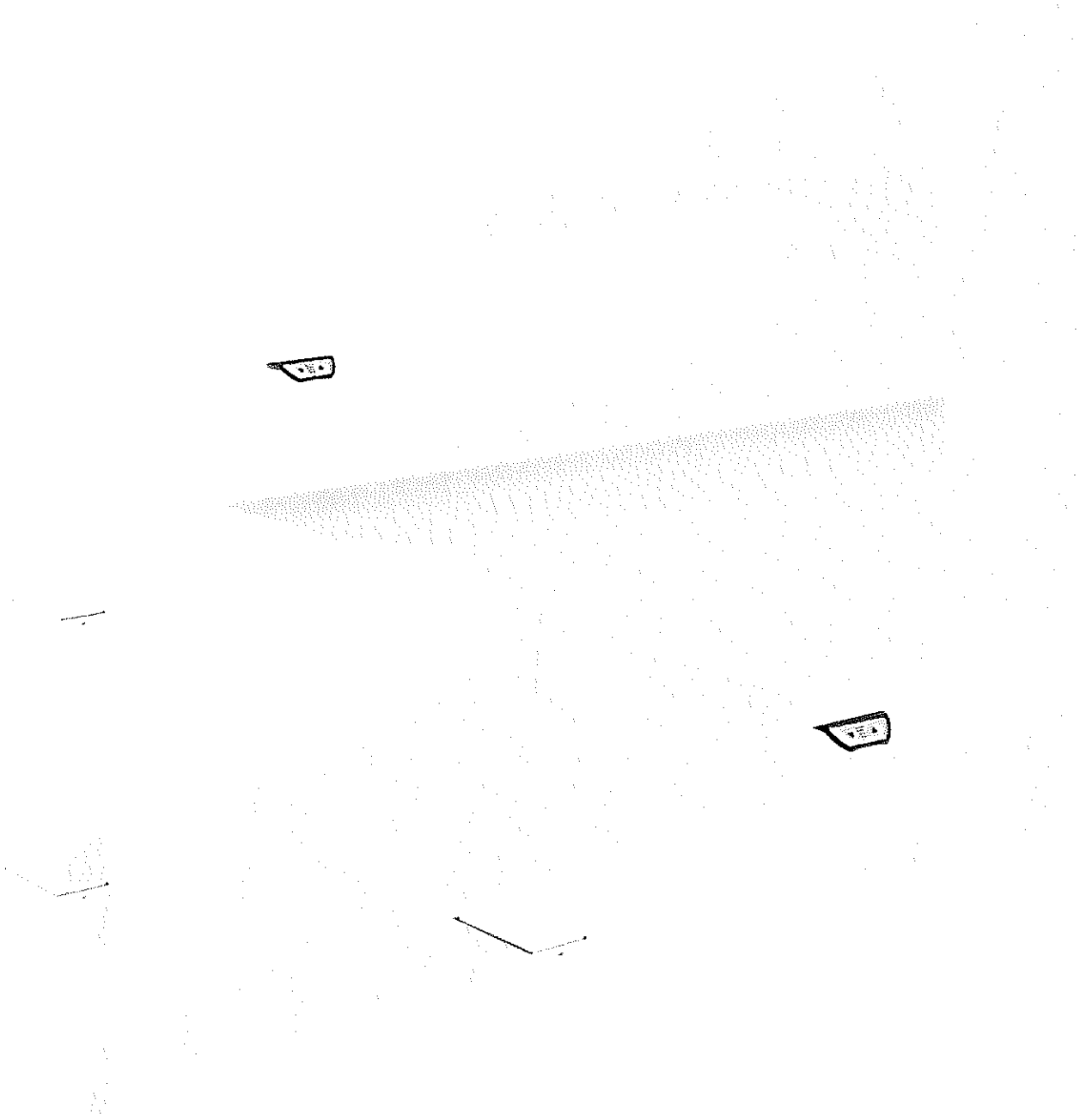

Motia is available with an electric standard base that has a height range of 27 to 46 inches and an electric extended base that has a height range of 22 to 48 inches.



Motia integrates with all Herman Miller workstations, including Action Office® seen here, to create a common aesthetic across the office environment. With a design that provides ample clearance for knees and legs, Motia offers maximum comfort to users.

Well-made Tables for Employee Well-being

Motia offers reliable height adjustability, durability, and stability backed by unmistakable Herman Miller quality and service. Designed to integrate with any workplace, Motia tables require minimal assembly upon delivery.

Ease into Sit-to-Stand Solutions

Height-adjustable solutions are gaining popularity within workplaces, promoting health and happiness. At an affordable price point, Motia is an opportunity to ease into height adjustability with a Herman Miller product.

Materials

Motia comes in a variety of surface colors and a choice of base finishes so you can personalize the look of the table. Visit hermanmiller.com/materials to see representational samples of our complete textile and materials offering.

Motia Sit-to-Stand Tables

Top / Edge Patterned Laminate

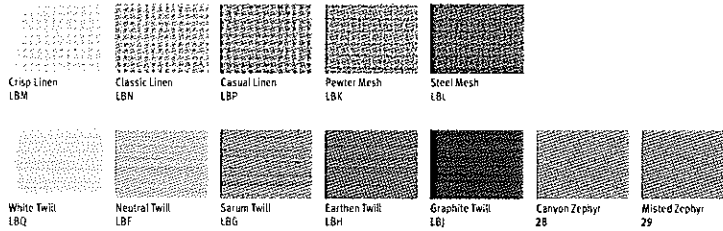

Solid Laminate

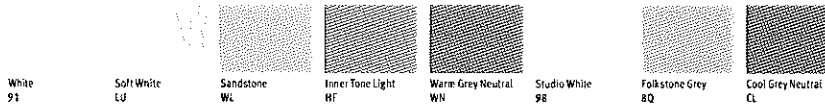

Woodgrain Laminate



Base Finish

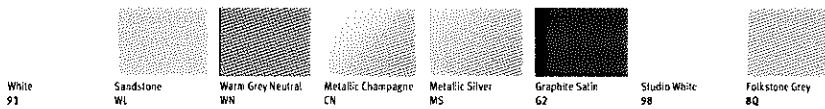

Components

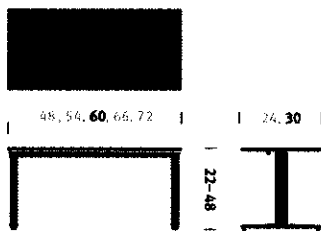

Rectangular Table with T-Foot



Mechanism
Electric Standard (E)
Electric Extended (D)

Sit-to-Stand Height Range
27" to 46"
22" to 48"

A Motia Base Kit is available for installation on applicable surfaces.

For more information, please visit hermanmiller.com or call 888 443 4357.

Herman Miller, and Action Office are among the registered trademarks of Herman Miller, Inc. Motia is among the trademarks of Herman Miller, Inc.

Printed in the USA. Please recycle.
© 2016 Herman Miller, Inc., Zeeland, Michigan 0.DV202
All rights reserved.

HermanMiller Motia[®] Sit-to-Stand Tables



Warranty

Work Surface: 12-year, 3-shift
Base: 5-year, 3-shift

Motia Sit-to-Stand Tables

In an ongoing effort to promote wellness in the workplace, the Motia Sit-to-Stand Table puts people and workplaces in motion. Moving with workers and their workflow, Motia enables a smooth transition between sitting and standing. Designed with quality, minimal materials, and available in various finishes, Motia makes height adjustability easy to afford, easy to use, and easy to integrate into any setting.

hermanmiller.com/motia-sit-to-stand-tables

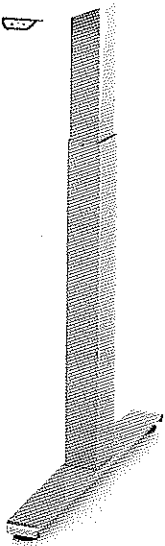
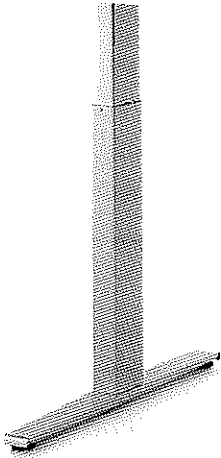

Rectangular Table with T-Foot



Mechanism
Electric Standard (E)
Electric Extended (D)

Sit-to-Stand Height Range
27" to 46"
22" to 48"

Motia Base Kits are available for installation on applicable surfaces.

HermanMiller

LS Series Keyboard Support



Designer

Knape & Vogt

Enjoy the comfort of working with your keyboard at the proper height and angle for your body. The slim-profile, adjustable support attaches to the work surface, letting you raise, lower, and tilt your keyboard into a position that feels right for you. It works with a variety of trays to support your technology and daily activities, and it stores neatly beneath the work surface in just two inches of space. Meets or exceeds ANSI/ BIFMA requirements.

Warranty

12-year, 3-shift
Please visit hermanmiller.com/warranty-terms for details.

hermanmiller.com/keyboard-supports



General Dimensions

A vertical adjustment: 8 7/8"
B tilt range: -20° rearward, 15° forward
Available with 17", 19", or 21 3/4" track.

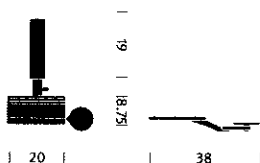

Y7737

The LS Series Keyboard Support is available with the following tray options:



| 19.5 | | 19.5 |

Mini HDPE Tray
Available with Swivel or Adjustable Mouse Tray



| 27 | | 19.5 |

27" HDPE Tray



| 20 | | 19.5 |

20" HDPE Tray
Available with Swivel or Adjustable Mouse Tray



| 20 | | 19.5 |

20" Aluminum Tray
Available with Swivel or Adjustable Mouse Tray



| 19.5 | | 19.5 |

White Phenolic Tray
Available with Swivel or Adjustable Mouse Tray

HermanMiller

LT Series Keyboard Support



Designer
Knapé & Vogt

Take advantage of horizontal, height, and tilt adjustments to keep your keyboard comfortably aligned with your body while you work. The LT Series Keyboard Support offers visual indicators to help you set the ideal position for any posture, technology, or person, including for people who are right- or left-handed. Combine it with a variety of different keyboard trays to support the way you work, and simply fold it back beneath the work surface and out of your way when not in use. Meets or exceeds ANSI/BIFMA requirements.

Warranty
12-year, 3-shift
Please visit hermanmiller.com/warranty-terms for details.

hermanmiller.com/keyboard-supports



General Dimensions

A vertical adjustment: 8 3/4"

B tilt range: -10° rearward

Available with 19" or 21 3/4" track.

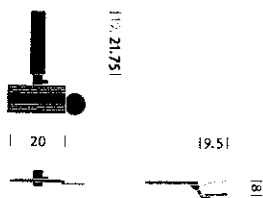

Y7727

The LT Series Keyboard Support is available with the following tray options:



| 19.5 | | 19.5 |

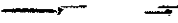

Mini HDPE Tray
Available with Swivel or Adjustable Mouse Tray



| 27 | | 19.5 |



27" HDPE Tray



| 20 | | 19.5 |



20" HDPE Tray
Available with Swivel or Adjustable Mouse Tray



| 20 | | 19.5 |



20" Aluminum Tray
Available with Swivel or Adjustable Mouse Tray

HermanMiller

LX Series Keyboard Support



Designer

Knape & Vogt

An extended range of motion lets you place your keyboard at the ideal height and angle for your body whether you choose to work sitting, standing, or to move between both postures. With the largest arc of adjustability in our product line, the LX Series Keyboard Support can be locked anywhere from 8 1/4 inches above the track to 5 7/8 inches below it. A soft touch knob lets you tilt the support back or forward to maximize your comfort in a variety of postures. A torsion spring keeps the keyboard secure while moving up and down. The support swivels 360 degrees to store beneath the work surface. Meets or exceeds ANSI/BIFMA requirements.

Warranty

12-year, 3-shift
Please visit hermanmiller.com/warranty-terms for details.

hermanmiller.com/keyboard-supports



General Dimensions

A vertical adjustment: 14.8"

B tilt range: -15° rearward, 10° forward

Available with 23" track.

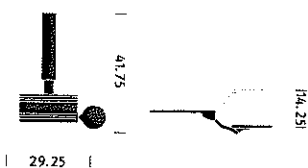

Y7724

The LX Series Keyboard Support is available with the following tray options:



| 19.5 | | 19.5 |

Mini HDPE Tray
Available with Swivel or Adjustable Mouse Tray



| 27 | | 19.5 |

27" HDPE Tray



| 20 | | 19.5 |

20" HDPE Tray
Available with Swivel or Adjustable Mouse Tray



| 20 | | 19.5 |

20" Aluminum Tray
Available with Swivel or Adjustable Mouse Tray



| 29.25 | | 13.25 |

Platform Concave Tray

HermanMiller

TL Series Keyboard Support



Designer

Knape & Vogt

Help your body, technology, and furniture stay in harmony with an adjustable keyboard support. This compact, slim-profile option can be mounted directly to the underside of a work surface in just 10 inches of space, making it ideal for surfaces with stiffeners or table troughs on the underside. A soft touch knob lets you tilt the support to maximize your comfort in a variety of postures. Available with a wide range of keyboard trays and mousing surfaces, the support folds back beneath the work surface and out of your way when not in use. Meets or exceeds ANSI/BIFMA requirements.

Warranty

12-year, 3-shift
Please visit hermanmiller.com/warranty-terms for details.

hermanmiller.com/keyboard-supports

General Dimensions

A vertical adjustment: 5.7"

B tilt range -15° rearward, 10° forward

Available with no track, 19" track, or 23" track.

| 19" / 3 |



| 31 |



| 21 |



Y7741

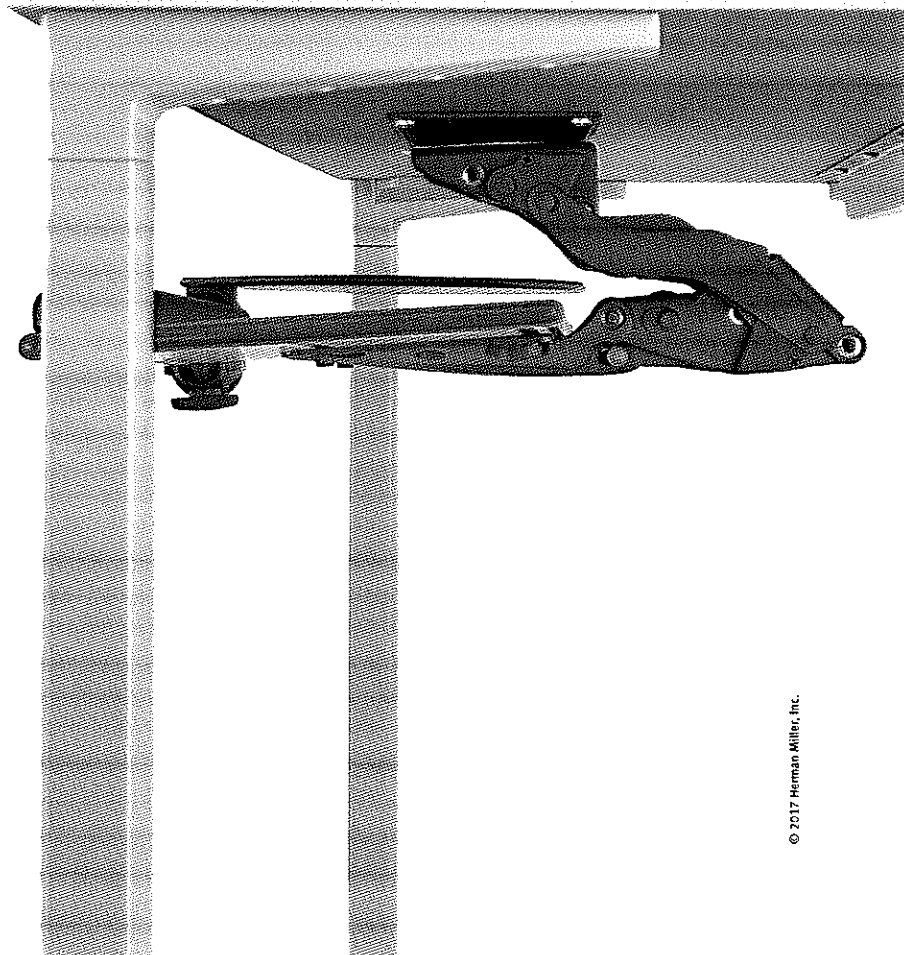

The TL Series Keyboard Support is available with the following tray options:



| 19.5 | | 19.5 |



Mini HDPE Tray
Available with Swivel or Adjustable Mouse Tray



| 27 | | 19.5 |



27" HDPE Tray



| 20 | | 19.5 |

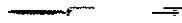

20" HDPE Tray
Available with Swivel or Adjustable Mouse Tray



| 20 | | 19.5 |



20" Aluminum Tray
Available with Swivel or Adjustable Mouse Tray



| 18.5 | | 19.5 |



White Phenolic Tray
Available with Swivel or Adjustable Mouse Tray

Herman Miller
Flo Monitor Arms

Lines 24 - 27 of AOI Proposal

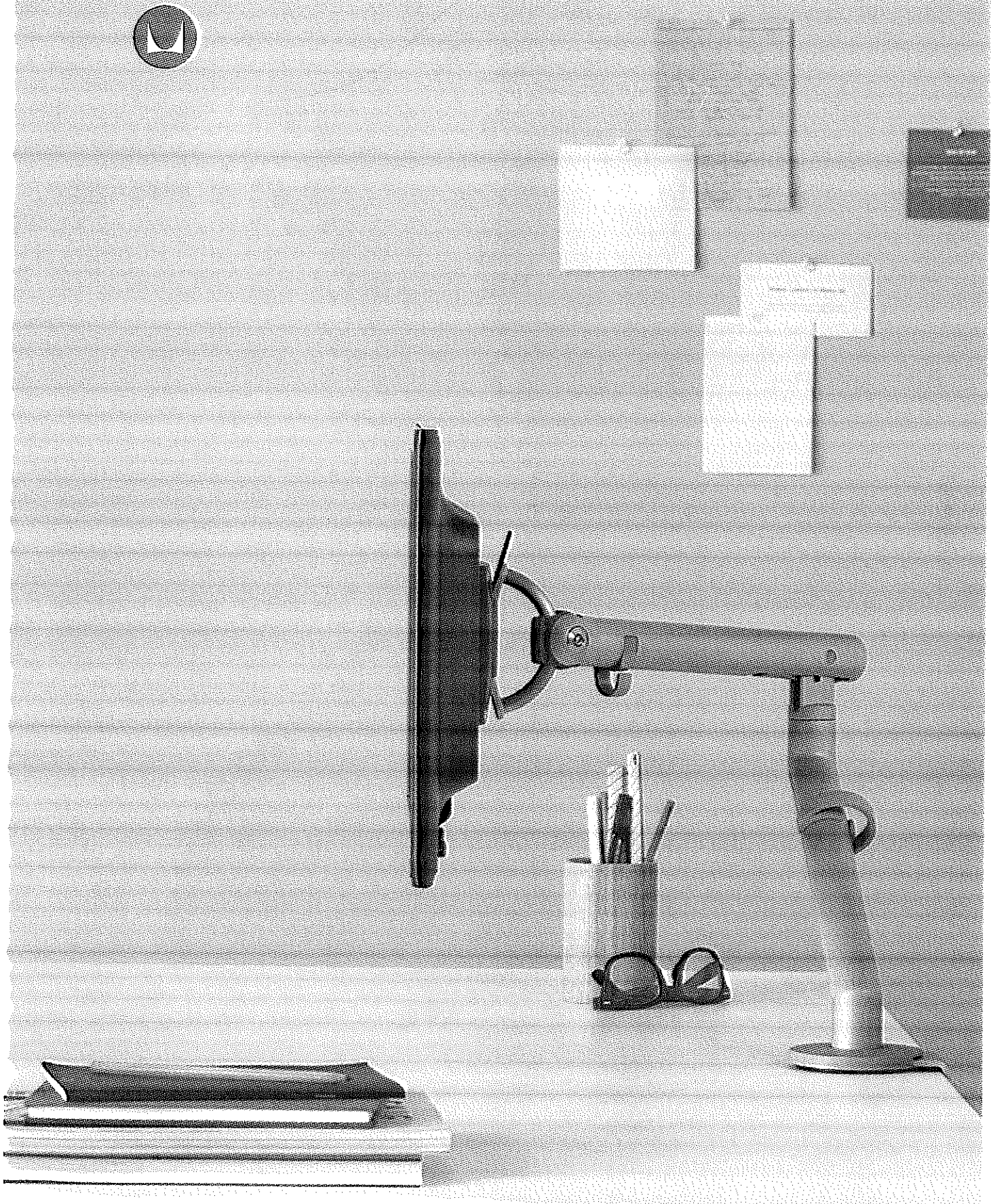

Perfect monitor placement for every
person, place, and posture



Flo Monitor Arms
Designed by Colebrook Bosson Saunders

If you can't adjust the placement of your monitor to a viewing angle and distance that's comfortable for your eyes, your body will compensate. Hunching over and craning your neck may bring your eyes closer to your screen, but doing so makes for an awkward and unhealthy working posture. It also negates many of the ergonomic benefits of sitting in a high-performance work chair.

Everyone's eyes are different, but everyone's solution for the ideal monitor placement can be the same. The Flo family of monitor arms is designed for smooth, intuitive adjustments that let you choose the height, viewing distance, and tilt angle of your monitor, helping you maintain a healthy posture.

As Dynamic and Intuitive as the Technology It Supports

Flo monitor arms are as simple to install as they are to use. All Flo models mount easily to a variety of worksurfaces, and a standard VESA mount fits most flat-panel monitors on the market. Flo arms also include integrated cord management to keep cables contained and workspaces tidy.

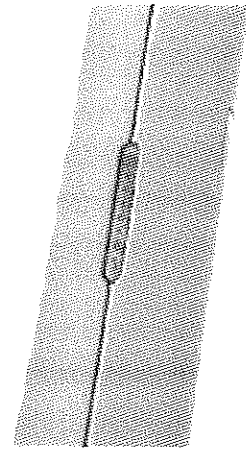

The counterbalance adjustment lets you set the optimal tension to provide stable support and fluid motion for a wide range of monitor sizes.

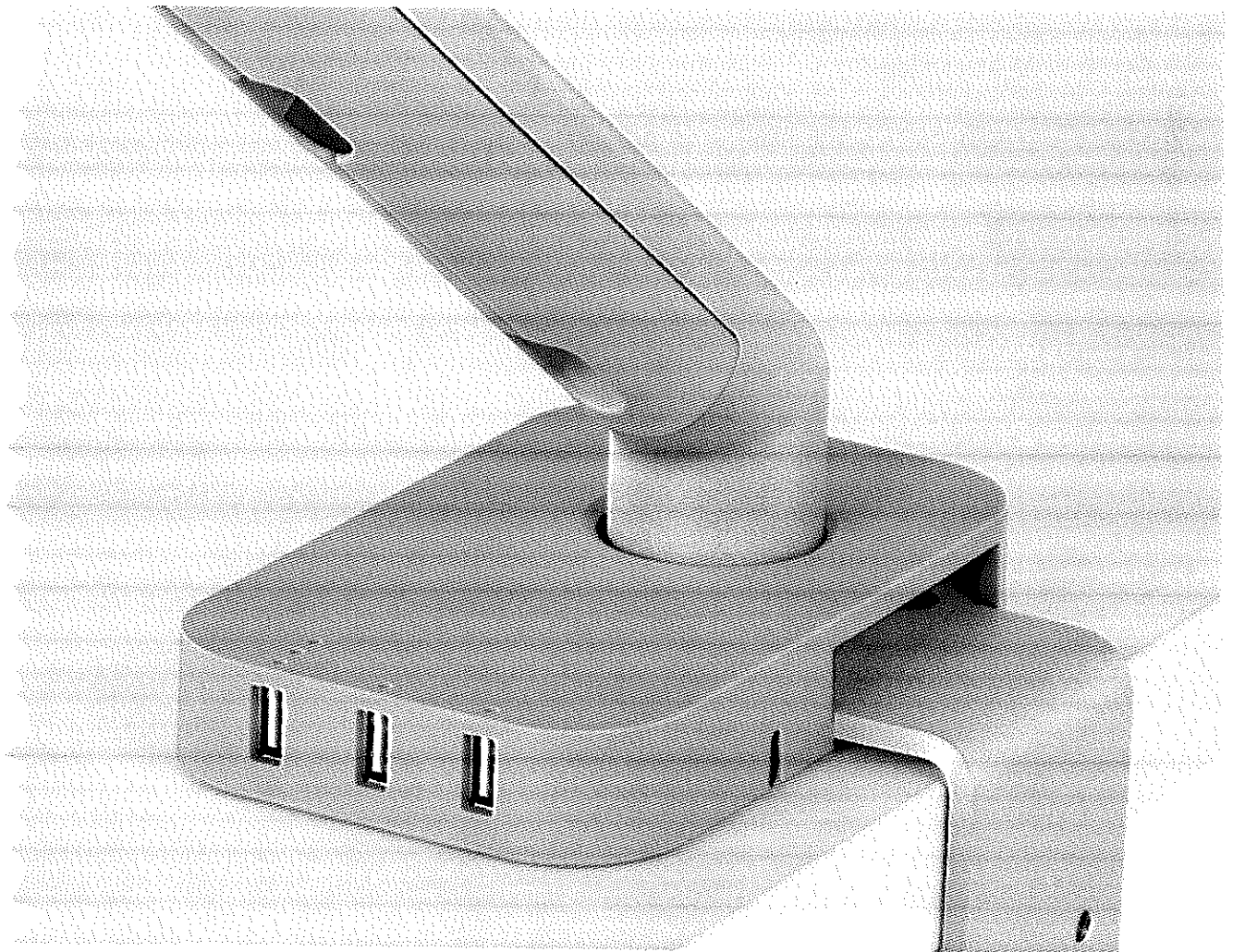

An optional USB clamp mount adds three convenient USB ports, including one designed for fast charging. The USB clamp mount is available on surface clamp-mounted Flo Modular Monitor Arms (holding up to two monitors) and Flo Single-Screen Monitor Arms.

Total Support System

Flo's unique design extends to a full suite of monitor arms, with solutions for single or multiple monitors and laptops.

Finish



Silver

White

Standard single Flo arms (Y91173) are available in White or Silver. All other Flo models are available in Silver only.

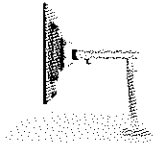

Flo
Y91171



Flo Dual
Y91175



Flo Modular
Y91176

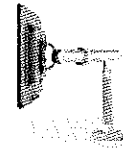

Flo Plus
Y91174.1

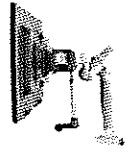

Flo Plus Dual
Y91174.2



1 Monitor



1 Monitor



1 Monitor



1 Monitor or all-in-one



2 Monitors



1 Laptop



2 Monitors

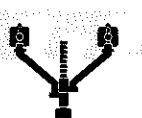

2 Monitors

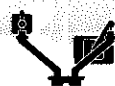

1 Monitor, 1 Laptop

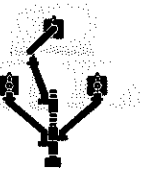

3 Monitors

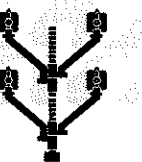

4 Monitors

For more information about our products and services or to see a list of dealers and retailers, please visit hermanmiller.com or call 888 463 4357.

Flo® is a registered trademark of Colebrook Bosson Saunders.

Printed in the USA. Please recycle this brochure.

© 2017 Herman Miller, Inc. Zeeland, Michigan Q.Y2020
All rights reserved.

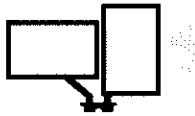

Unsurpassed Range

Up and down, swivel and tilt, portrait or landscape. Flo offers a range of articulation better than any other monitor arm in its class.



No Tools, Just Touch

Flo's patented geometric spring technology allows fluid, fingertip control of monitor placement with minimum effort and maximum precision—no locking or tightening required.



Heavy-Duty Capacity

Flo Plus Single provides a heavy-duty solution for single monitors between 20 and 40 lbs. Flo Plus Dual can hold two monitors, weighing 10 to 20 lbs. each. Flo Plus can support two monitors on the same arm with a single point of adjustment.

HermanMiller Altissimo-Prime™ Sit-Stand Workstation

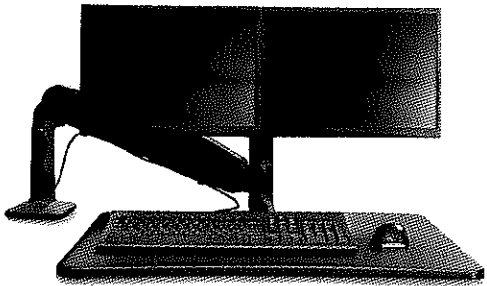

Y7800. 20H Dual Screen Option

Product Description and Launch Announcement



Herman Miller is pleased to announce the launch of the Altissimo-Prime™ Sit-Stand Workstation; a price and market competitive single surface sit-stand workstation solution that uses gas assist counter balance technology to control the arm through 18.5" of smooth acting height adjustment.

Mounted to the back of the desk, the Altissimo-Prime economically transforms it into a sit-stand workstation. The smooth adjustment arm enables the user to effortlessly move the work surface up-or-down plus side-to-side to maximize the usage of the desk surface. The arm is designed to support 6.5-24.5 lbs. of total weight capacity and is capable of accommodating a wide range of technology requirements with counter balanced movement and functionality. Cable management clips on the workstation arm easily capture all the technology cables for a compact and neat installation.

With the soft touch knob and safety stop, the monitor can be adjusted through 6.3" of height adjustment range allowing the user to find the best monitor position. An optional dual screen adapter kit provides support for two monitors up to 24" wide weighing up to 24.5 lbs. total.

The Altissimo-Prime has a large 28" x 18" work surface that is spacious enough to accommodate any keyboard and mouse with plenty of room for other extra items. The tray can be under-or-over mounted to allow users the flexibility of an obstruction free work surface or a work surface flush to the desk.

The Altissimo-Prime is GSA eligible and has a five year warranty and is available in black or silver to compliment most workspaces with excellent fluid sit-stand adjustment.

Key Features and Benefits

Features	Benefits
Height adjustment range of 18.5"	A large adjustment range allows most users to experience the benefits of a sit-stand workstation
6.5-24.5 lbs. total weight capacity (Y7800.1) 1.5-19.5 lbs. total weight capacity (Y7800.2)	Accommodates a wide range of technology requirements with balanced functionality
Well sized 28" x 18" work surface	The spacious work surface accommodates any keyboard and mousing device with plenty of room for extras
Under-or-over tray mount option	Flexible option for an obstruction free work surface or a work surface flush to the desk
Integrated cable management system	Cable management clips easily enable the user to store all their technology cables neatly and securely
6.3" of independent monitor height adjustment	Use the soft touch knob, with safety monitor stop, to adjust the monitor height to desired positions
180° independent monitor swivel	Information sharing is seamless
Monitor tilts, rotates and pans	Easily arrange the screen into the most optimal viewing angle for maximum comfort and productivity
Quick connect VESA plate	Saves time for quick installations and allows for easy removal of monitors for storage or security purposes
Available as either single or dual monitor unit	Monitor flexibility allows end users to customize their technology solution
Grommet and clamp mounts are provided	Installation versatility makes the Altissimo-Prime™ compatible with almost any desk or work surface and allows the arm to be positioned in the most suitable location to ensure optimal reach and positioning.
TAA Compliant	A requirement of many governmental purchasing contracts
Multiple color options available	Offered in black or silver designed to complement existing office environments and new décor trends
5 Year Warranty	The Altissimo-Prime has been product tested to over 20,000 cycles exceeding the industry standard by 100% and ensuring consist performance and flexibility

Packaging

The Altissimo-Prime will be individually packaged as a pre-assembled product.
The box dimensions are 22" wide x 40" long x 9" height and weighs 35 lbs.

TAA Compliance

The Altissimo-Prime Sit-Stand Workstation is classified as TAA compliant.

LEED Recyclability Calculations

	Weight in lbs	Recycled Content %
Total weight of Altissimo-Prime	29.03	—
Recycled Content Total (lbs.)	19.8	68%
Post Industrial (lbs.)	7.8	27%
Post-Consumer (lbs.)	12	41%
Recyclability of Product	28.83	99%

LEED Credit Ratings

Y7800.20H
Dual Screen Option

LEED CI Credit	Product
Manufacturing & Resources	
MR Credit 4.1 Required Recycled Content, 10%	Altissimo-Prime
MR Credit 4.2 Required Recycled Content, 20%	Altissimo-Prime
Innovation & Design Process	
Credit 1.1 – 1.4 Innovation in Design Ergonomic products could be credited as part of an implemented Ergonomic Strategy	Altissimo-Prime

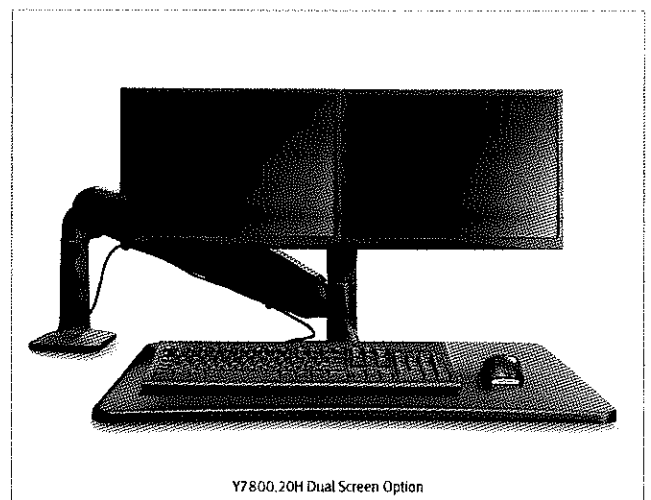
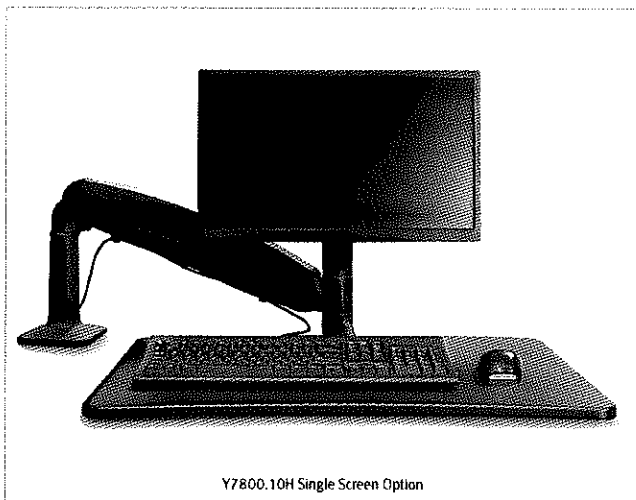



Part Numbers, Description & Pricing

HMI Part Number	Description	Color	Weight (lbs)	List Price - ZZ Product Line Code
Y7800.10H	Altissimo-Prime - Single Screen, includes MDF work surface tray	Satin Black	35.0	\$920
Y7800.20H	Altissimo-Prime - Dual Screen, includes MDF work surface tray, (comes in two cartons)	Satin Black	35.0 6.0	\$1,070
Y7800.10I	Altissimo-Prime - Single Screen, includes MDF work surface tray	Silver	35.0	\$920
Y7800.20I	Altissimo-Prime - Dual Screen, includes MDF work surface tray (comes in two cartons)	Silver	35.0 6.0	\$1,070



For more information about Altissimo-Prime™ contact Herman Miller via email at accessories_product@hermanmiller.com or by phone at 866 854 3048.

For more information about our products and services or to see a list of dealers and retailers, please visit hermanmiller.com or call 888 443 4357.

Altissimo-Prime is a registered trademark of Knape & Vogt.

Printed in the USA. Please recycle this brochure.

© 2017 Herman Miller, Inc. Zeeland, Michigan 0.Y2020
All rights reserved.



[Where to Buy](#) [Newsletters](#) [Contact](#)

[PRODUCTS](#) [DESIGN RESOURCES](#) [RESEARCH](#) [WHY MAGAZINE](#) [ABOUT US](#) [STORE](#)

[Products](#) [Accessories](#) [Technology Support](#) [Wall-Mounted Technology FX Series](#)

Wall-Mounted Technology FX Series

[Images](#)

[Product Downloads](#)

[Where to Buy](#)

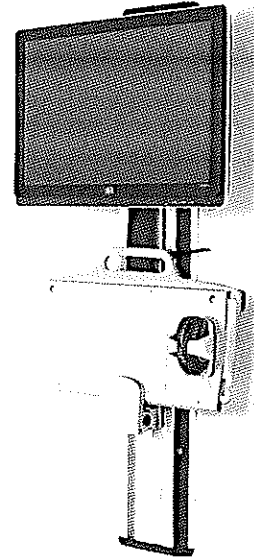

What's In It For You



[Product Story](#)



[Easy Installation](#)



[Supports Your Needs](#)

Product Story

Use this slim-line option when space is at a premium. This track-mounted support holds monitors up to 15 pounds and folds within four inches of the wall when not in use. Anti-microbial finishes and integrated wire management come standard. Attachable CPU support is also available. Ideal for education and healthcare hallway environments

Thrive Portfolio Feel Better, Work Better.

[Part of the Thrive Portfolio](#)
[Learn more](#)

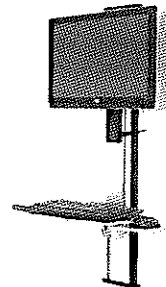

[Site Map](#) [Legal](#) [Terms of Use](#) [Privacy](#) [Site Feedback](#) | [Other Sites](#) [United States](#)

© 2017 Herman Miller, Inc.



Wall-Mounted Technology HD Series

- [Images](#)
- [Product Downloads](#)
- [Where to Buy](#)



Photo Gallery

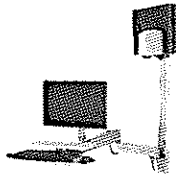

Thrive Portfolio
Feel Better. Work Better.

Part of the Thrive Portfolio
[Learn more](#)

What's In It For You



Product Story



Reach



Easy Installation



Supports Your Needs

Product Story

Built for heavy-duty technology use, this track-mounted support can hold up to 40 pounds, then fold within seven inches of the wall when not in use. Treated with antimicrobial finishes, it features a second surface to rest a clipboard or chart. Available with an attachable CPU support, it is ideal for use with high-definition screens or all-in-one CPUs in clinical or patient bedside settings.

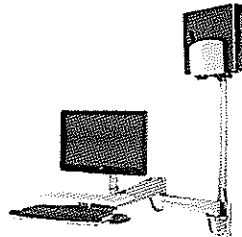



[Where to Buy](#) [Newsletters](#) [Contact](#) [Customer Service](#) [Search](#)

[PRODUCTS](#) [DESIGN RESOURCES](#) [RESEARCH](#) [WHY MAGAZINE](#) [ABOUT US](#) [STORE](#)

[Products](#) [Accessories](#) [Technology Support](#) [Mbrace Wall-Mounted Technology](#)

Mbrace Wall-Mounted Technology

[Images](#)

[Product Downloads](#)

[Where to Buy](#)

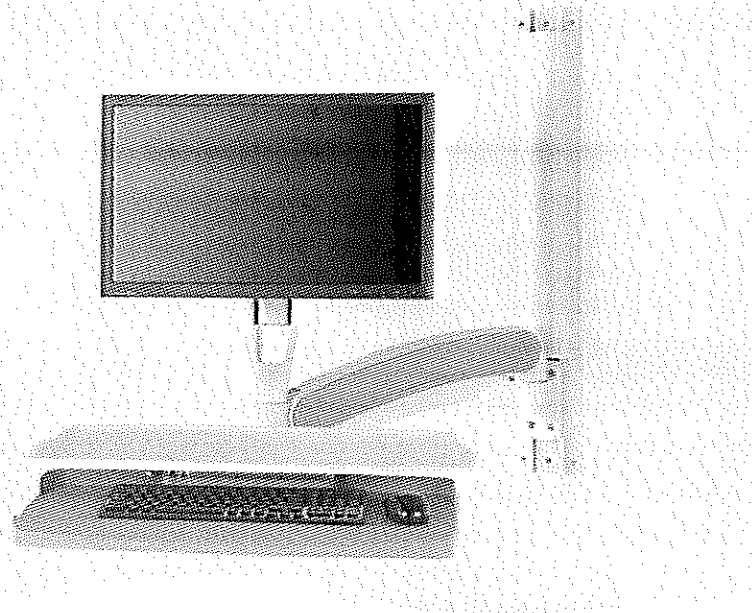

What's In It For You

- [Product Story](#)
- [Range of Motion](#)
- [Easy Installation](#)
- [Supports User Needs](#)

Product Story

Perfectly suited for inpatient alcoves or bedside applications Mbrace makes it easy for caregivers to share information and optimize needed space. It folds to within 9.5 inches from the wall and stores technology of up to 20 pounds. It has a 22-inch height-adjustment range, which accommodates seated or standing positions for most people, regardless of their size. A counterbalance mechanism allows for knob-free repositioning, so anyone can adjust the support and use it comfortably. Because the keying surface and monitor support are designed to move together, a person can use just one hand to operate it. Mbrace can be installed in about 30 minutes.

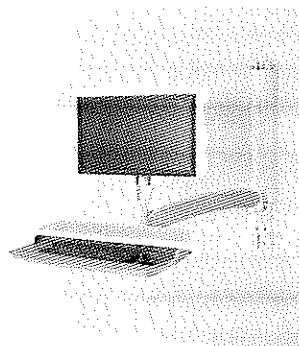

Thrive Portfolio Feel Better, Work Better.

[Part of the Thrive Portfolio](#)
[Learn more](#)

[Site Map](#) [Legal](#) [Terms of Use](#) [Privacy](#) [Site Feedback](#) | [Other Sites](#) [United States](#)

© 2017 Herman Miller, Inc.

Freestanding Palm Rest

Y7751.

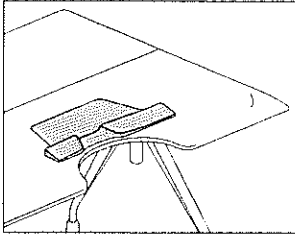

Thrive® Technology Support

Product Information

Description

This foam palm rest is designed to provide palm support along the front edge of a keyboard. It has an integrated flat base that fits beneath the keyboard to keep it in position. The palm rest is 20 1/4" wide. Finish is black.

Dimensions

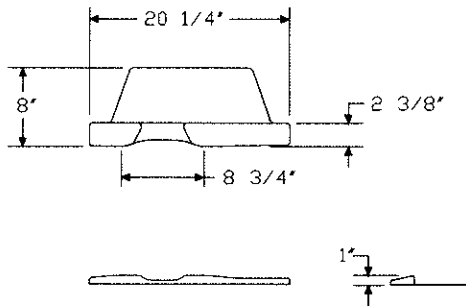

Specification Information

Step 1.

Y7751.

\$70

Palm Rest, Keyboard Tray

Y7790.

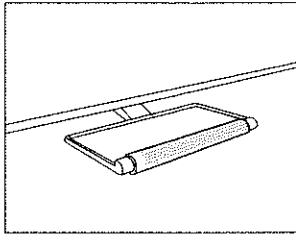

Product Information

Description

This palm rest attaches to the front edge of an injection-molded keyboard tray and provides a soft contact surface. Finish is black umber.

Dimensions

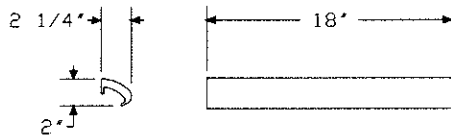

Specification Information

Step 1.

Y7790.

\$51

Thrive® Technology Support

Palm Rest, Input Device Platform Y7792.

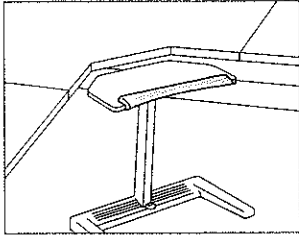

Thrive® Technology Support

Product Information

Description

This palm rest attaches to the front edge of an input device platform. It provides a soft contact surface and supports a user's palms. Finish is black umber.

Dimensions

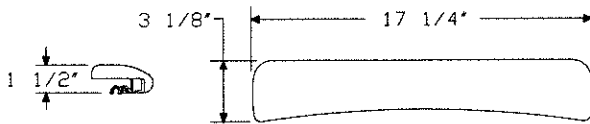

Specification Information

Step 1.

Y7792.

\$95

Keyboard Systems



Humanscale •

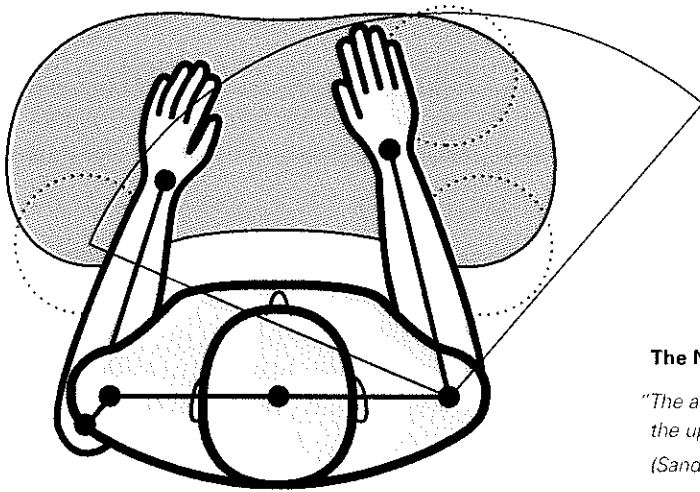
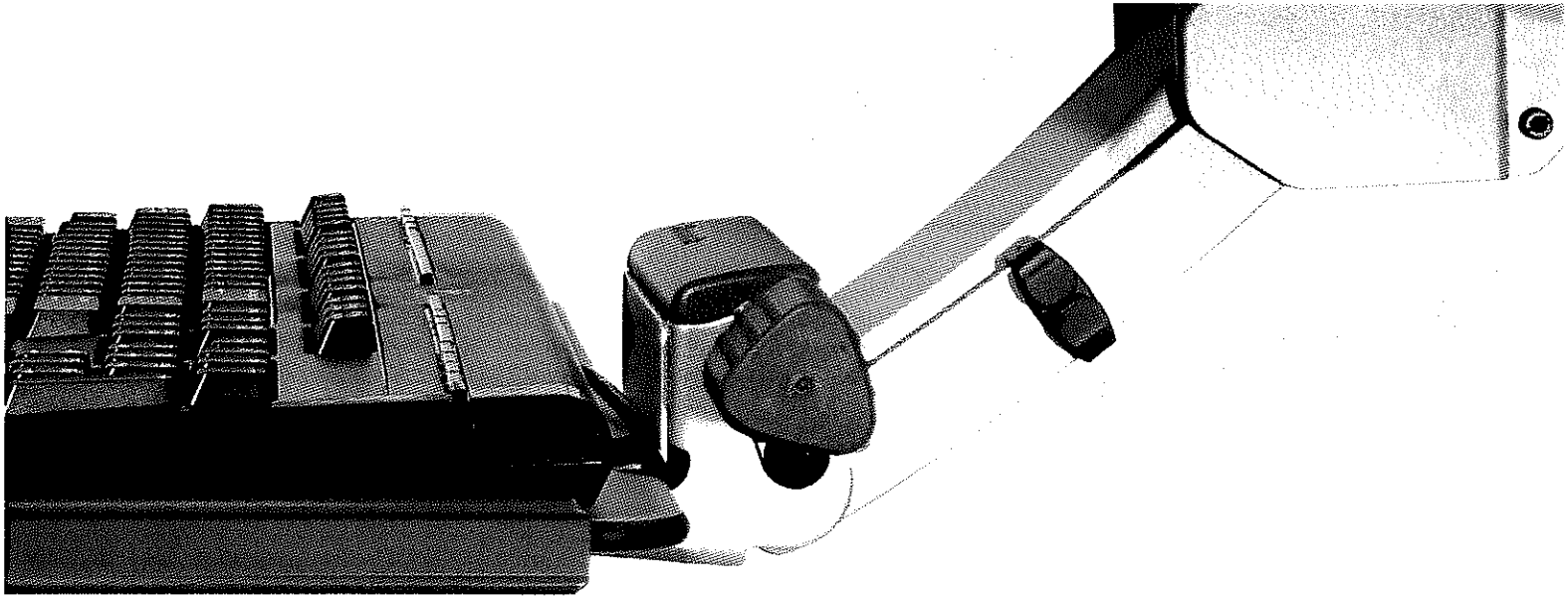

The Neutral Reach Zone

"The area that can be conveniently reached with a sweep of the forearm while the upper arm hangs in a natural position at the side."

(Sanders & McCormick, 1993)

Humanscale keyboard systems ensure nearly all users can work consistently within their Neutral Reach Zone to maintain a low-risk posture.

Keyboard Components

Mechanisms

Humanscale offers nine award-winning, negative-tilt mechanism options, from our original standard-bearer, the 2G, to our latest 5G, which combines easy dial-a-tilt and height adjustability with the strongest, most stable arm on the market. All of our mechanisms encourage low-risk typing postures and feature easy and intuitive adjustability.

Keyboard Platforms

Made of 1/4" phenolic resin, which combines strength, durability and a slim profile, Humanscale's wide range of keyboard platform options will accommodate any need. Available with Technogel or foam palm supports.

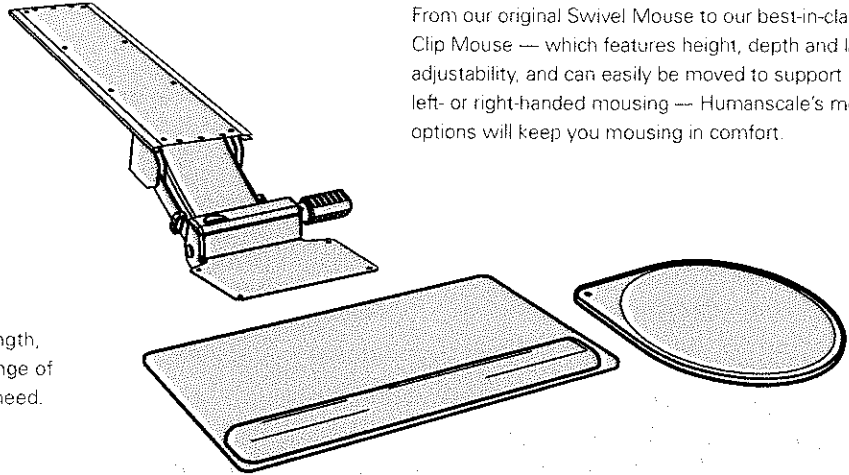

Mouse Platforms

From our original Swivel Mouse to our best-in-class Clip Mouse — which features height, depth and lateral adjustability, and can easily be moved to support left- or right-handed mousing — Humanscale's mouse options will keep you mousing in comfort.

Desk Configuration Compatibility Guide

Humanscale Keyboard Systems offer mix-and-match components for a custom solution to virtually any desk situation. Here are a few recommended platform options for some of the most common desk configurations. Consult your Humanscale rep for the Keyboard System solution that's right for you.

Straight Desk Configuration

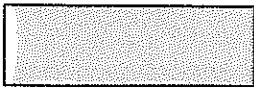

Recommended Platforms

- 900 Standard keyboard platform with Clip Mouse *shown*
- 500 Big keyboard platform *shown*
- 950 Standard Compact keyboard platform with Clip Mouse
- 550 Big Compact keyboard platform

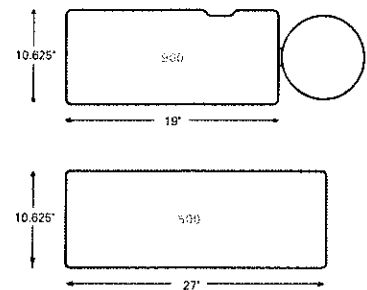

Diagonal Desk Configuration

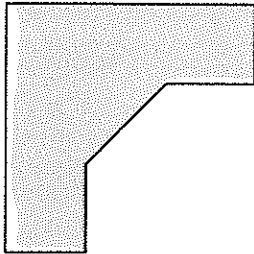

Recommended Platforms

- 700 Diagonal keyboard platform with Clip Mouse *shown*
- 400 Diagonal Big keyboard platform *shown*
- 900 Standard keyboard platform with Clip Mouse
- 950 Standard Compact keyboard platform with Clip Mouse

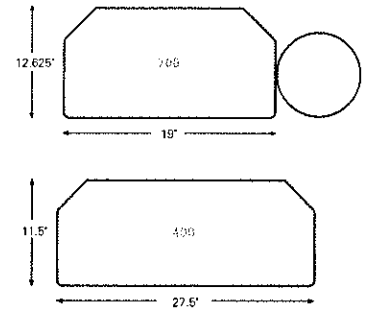

Radiused Desk Configuration

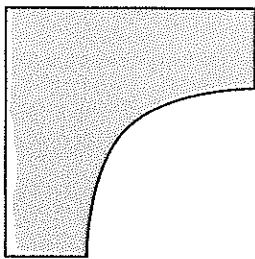

Recommended Platforms

- 800 Radiused keyboard platform with Clip Mouse *shown*
- 550 Big Compact keyboard platform *shown*
- 900 Standard keyboard platform with Clip Mouse
- 950 Standard Compact keyboard platform with Clip Mouse

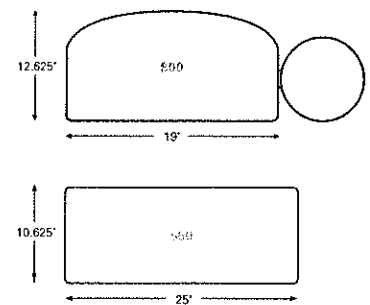

90-Degree Desk with DE200 Corner Sleeve Configuration

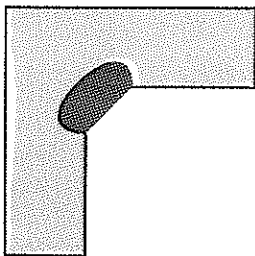

Recommended Platforms

- 950 Standard Compact keyboard platform with Clip Mouse *shown*
- 600 Extender keyboard platform with Clip Mouse *shown*
- 700 Diagonal keyboard platform with Clip Mouse
- 900 Standard keyboard platform with Clip Mouse

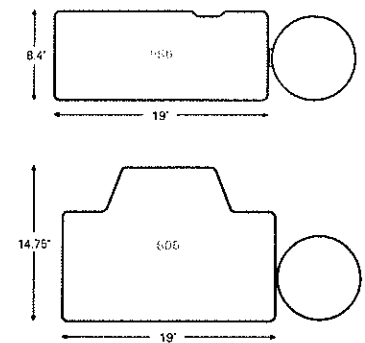

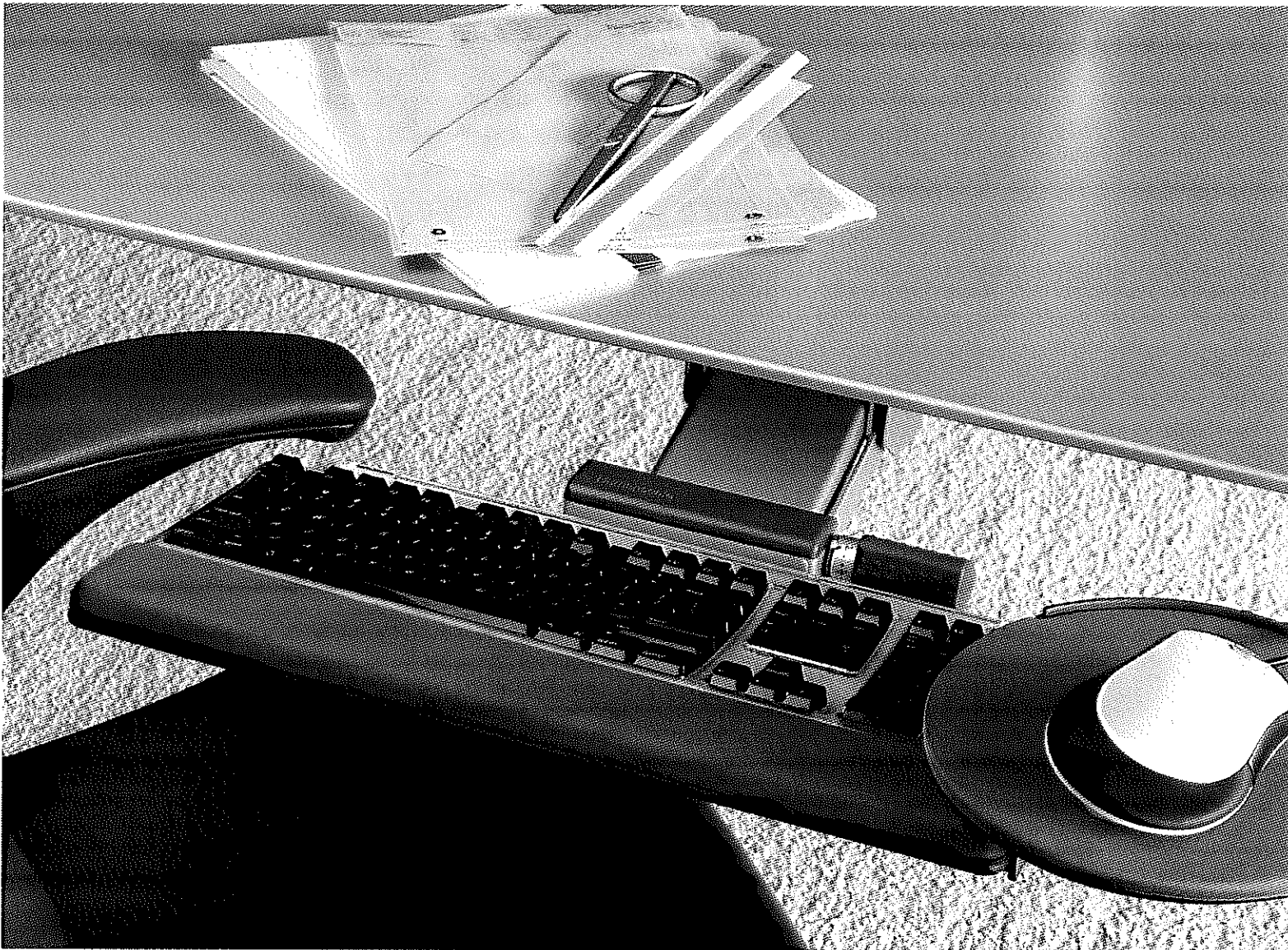

HSKB0109



*Recognized by I.D. Magazine as one of the
10 "Best Companies" worldwide that help
push design forward.*

www.humanscale.com

M8™
Monitor Arm

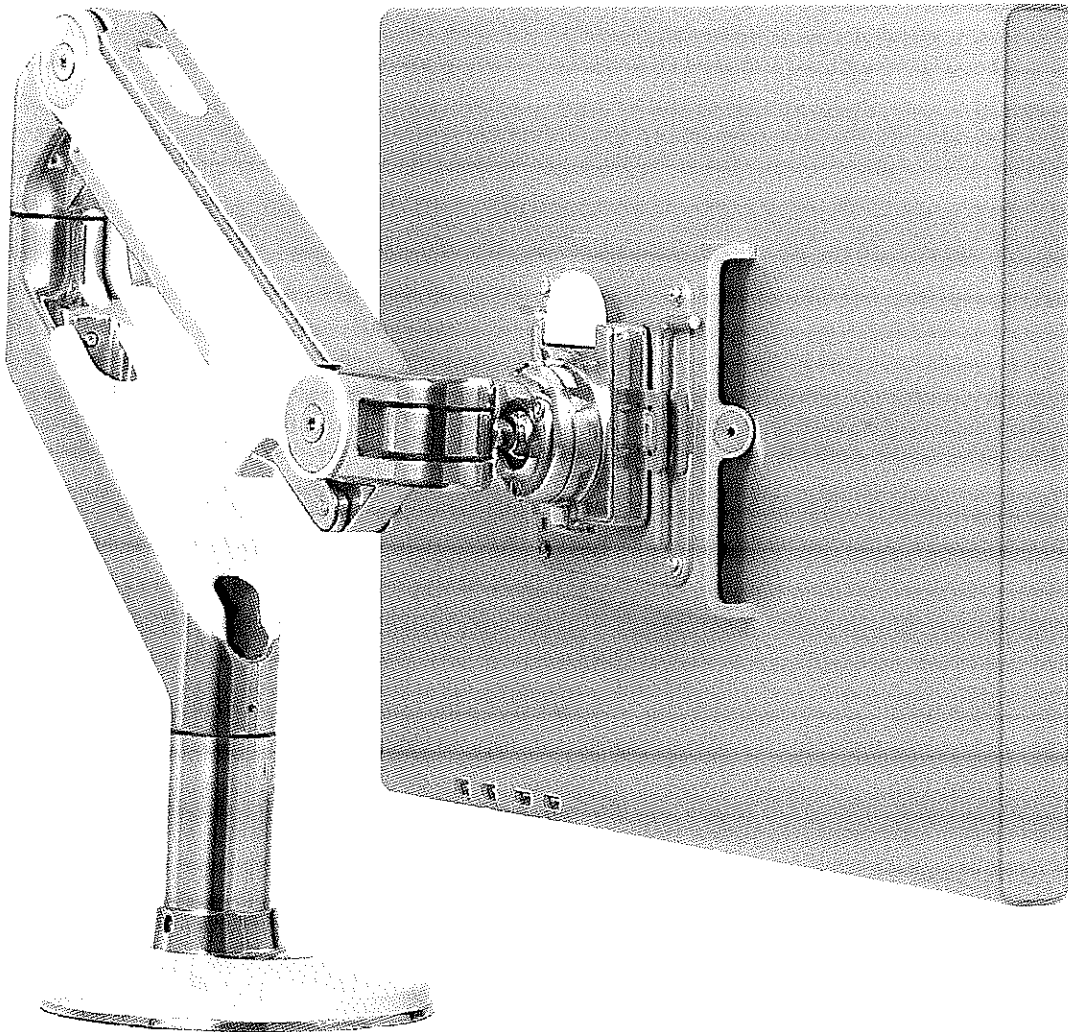

The Best of Both Worlds

Featuring incredible weight capacity in a sleek, slim profile, the M8 monitor arm is the perfect fusion of style and strength.

Through its unique construction, the M8 accommodates virtually any single- or dual-monitor configuration weighing up to 40 pounds. And unlike other high-capacity monitor arms, whose bulky designs restrict their performance, the M8 offers effortless adjustment and flawless ergonomic function.

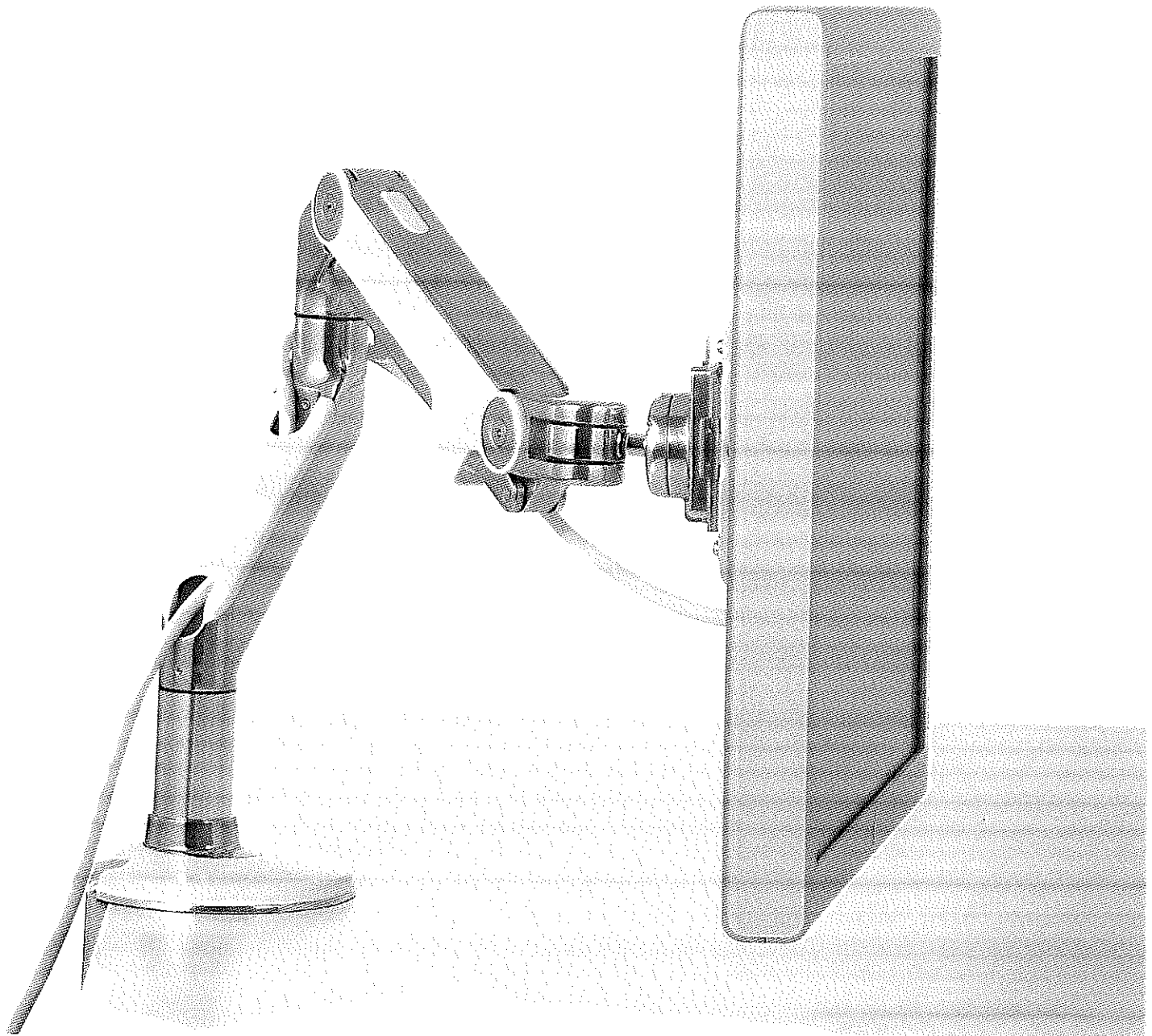

M8 for Single Monitors

The M8's high-performance design easily accommodates heavy monitors, but also provides the flexibility to support monitors weighing as little as eight pounds. Precision engineering makes it all possible, as the M8 features an internal counterbalance that easily adjusts to provide the right amount of support.

As a result, the M8 is versatile enough to meet the ever-changing demands of tomorrow's workplace.

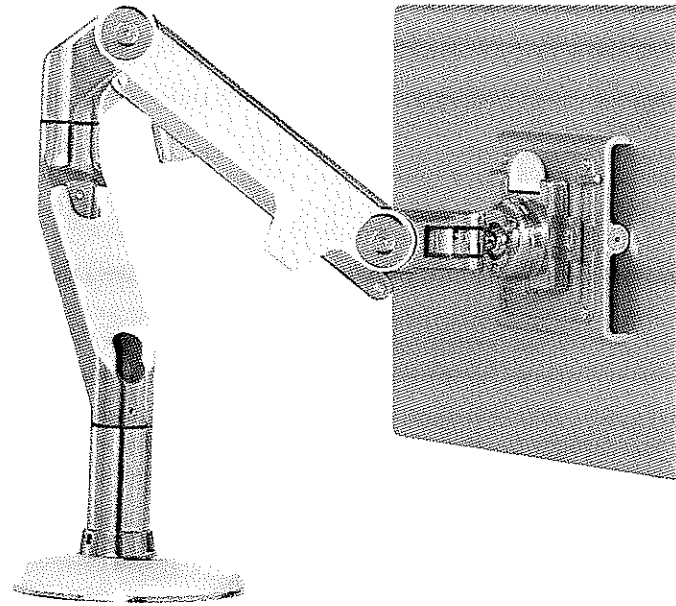

M8 for Dual Monitors

The M8's extreme weight capacity makes it ideal for supporting dual-monitor applications.

Using an optional crossbar support, the M8 accommodates two monitors—each weighing up to 20 pounds—arranged side-by-side. Monitors mounted to the crossbar adjust simultaneously for easy repositioning and excellent ergonomics. Plus, each monitor can be adjusted independently via a fine-tune adjuster for perfect alignment and a smooth aesthetic.

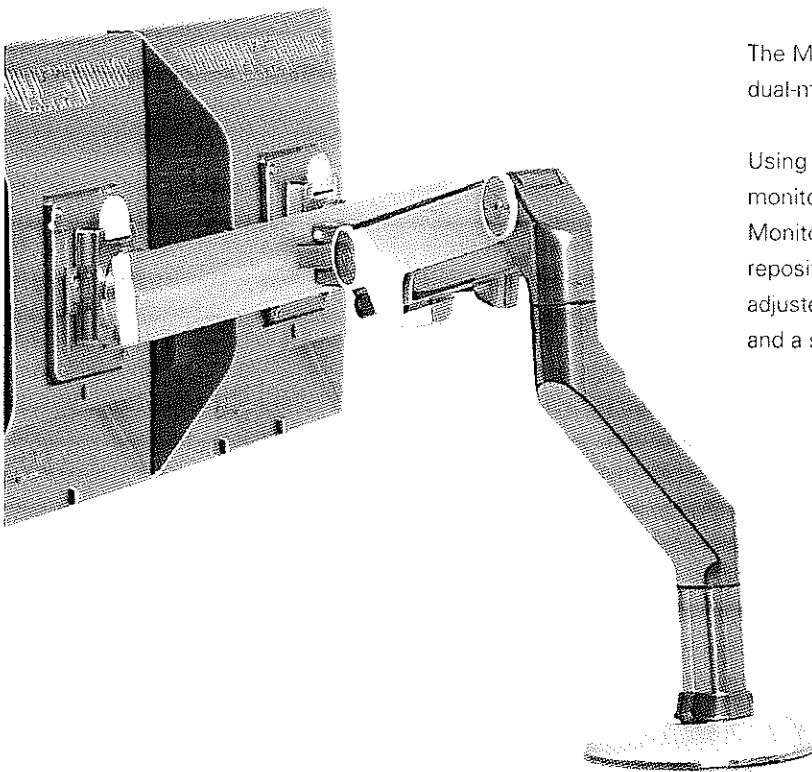

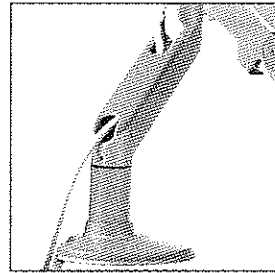
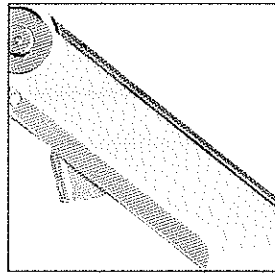

Features

- Modular design features interchangeable links to accommodate most applications
- Built-in security system provides effective theft-deterrent for public areas
- Humanscale's Quick Release ball joint facilitates fast and easy monitor installation and removal
- Built-in fine-tune adjustment ensures dual monitors line up perfectly
- Optional Notebook Holder accommodates laptops 9" – 14" in length
- Optional 12" links provide greater adjustability and flexibility
- 180° stop mechanism prevents wall damage from over-rotation
- Integrated cable management system hides cable clutter for improved organization and aesthetics

Specifications

- Accommodates virtually any single monitor from 8 – 40 lbs or dual monitors up to 20 lbs each
- Arm reach: 22"
- Height adjustment range: 11.5"
- Mount options: Clamp Mount, Bolt-Through Mount, Universal Slatwall Mount, Wall Stud Mount
- Finish options: Polished Aluminum with White accents, Silver with Gray accents
- May contribute to a number of valuable LEED credits
- 10-year, 24/7 warranty

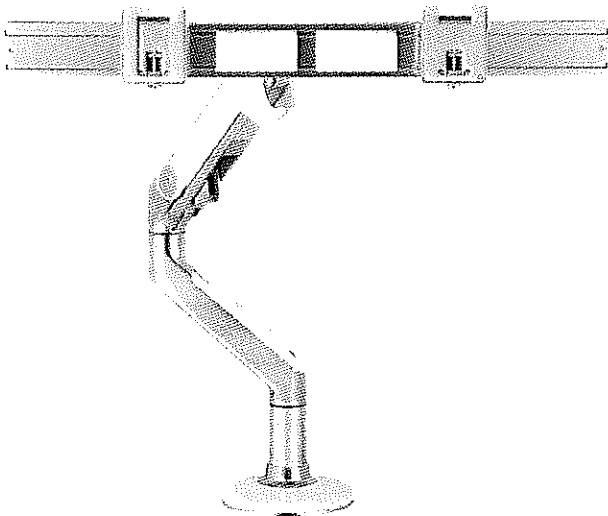

Creating a more comfortable place to work

www.humanscale.com
800.400.0625

M2™
Monitor Arm

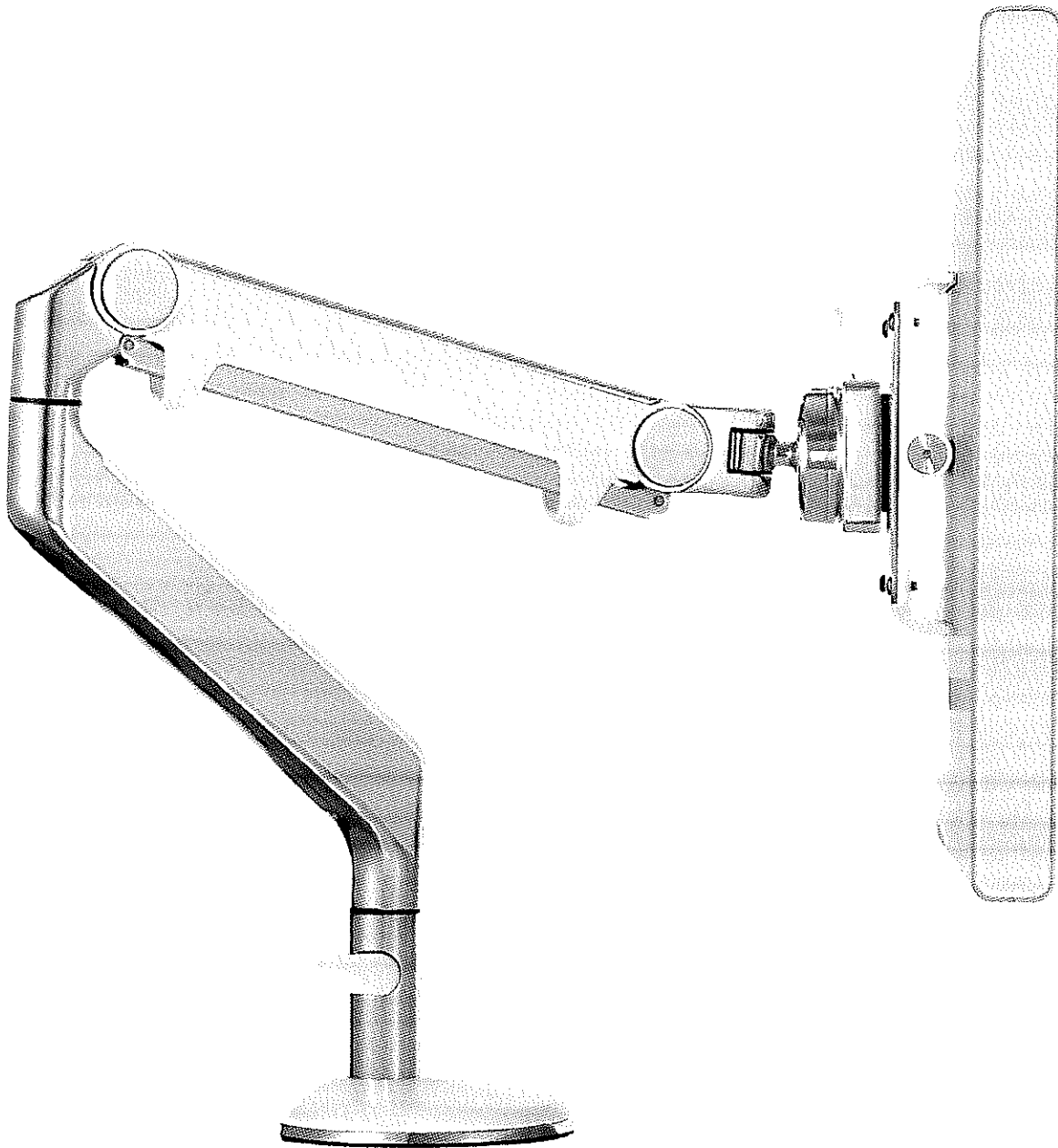

The Next-Generation Monitor Arm

Offering all the benefits of a traditional dynamic monitor arm—with none of the shortcomings—the M2 redefines high-performance monitor arms.

Current generation monitor arms use a gas cylinder to support the weight of the monitor. The M2 instead uses an innovative mechanical spring to achieve exceptional performance and durability in a lightweight, ultra-thin design.

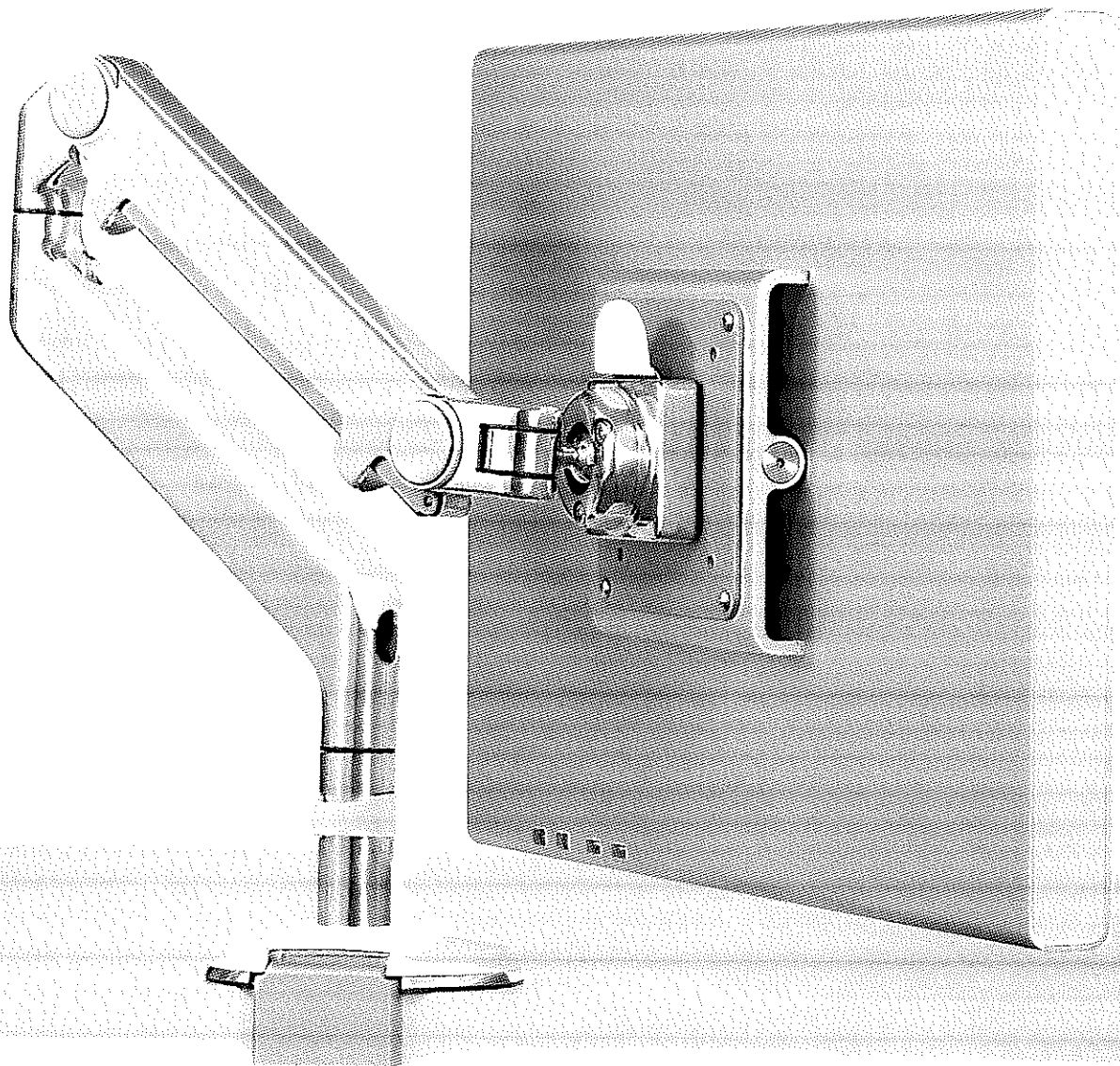

The Benefits of Mechanical Spring Technology

Design

The M2 is thin, light and easy to maneuver, and its sleek aesthetic complements the thin profiles of today's flat panel monitors.

Durability

With no gas cylinder and fewer parts than current-generation arms, less can go wrong with the M2 over time. As a result, it's backed by an industry-best 15-year 24/7 warranty.

Performance

Designed to support the vast majority of monitors in use today and offering effortless adjustment of both height and depth, the M2 will accommodate virtually every application for single monitors.

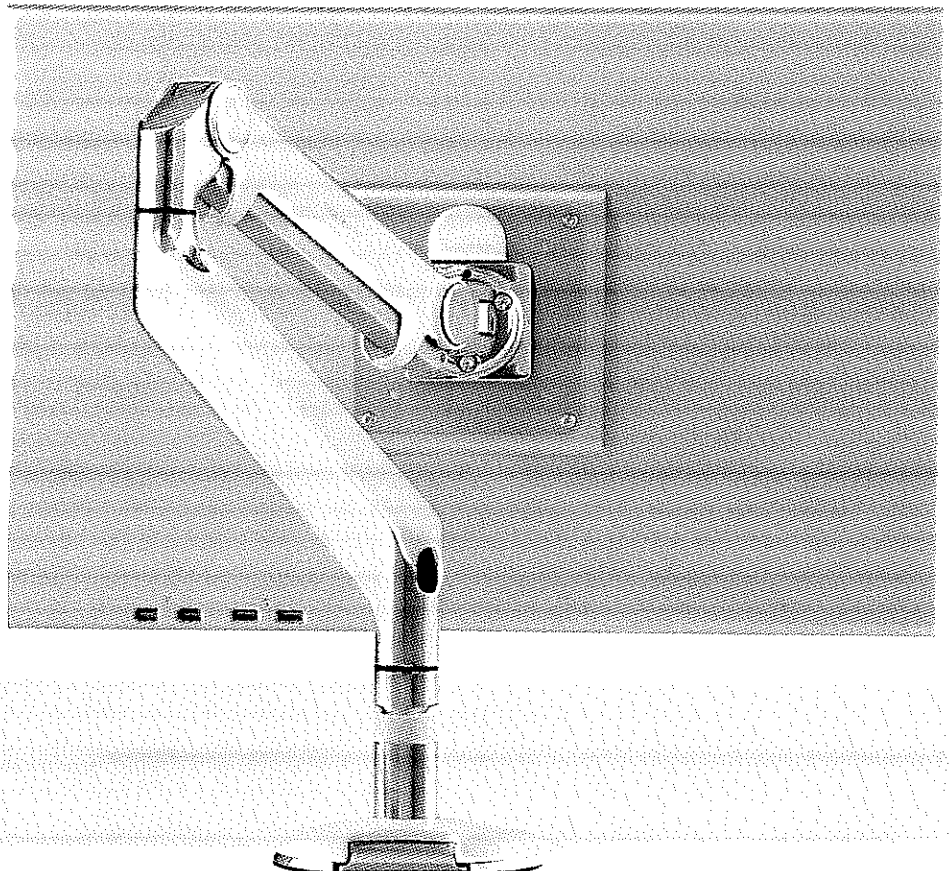



A New Level of Sustainability

For all its advancements, the M2's most notable achievement is that it treads lightly where the environment is concerned.

- Fewer parts mean fewer manufacturing processes
- Lighter weight means less resources used in shipping
- Slim profile enables less wasteful packaging
- Durable design means it won't need to be replaced for a very, very long time
- No gas cylinders, which are difficult to recycle
- Contributes to valuable LEED-CI, -NC and -EB credits

Features & Specifications

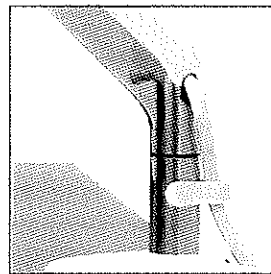
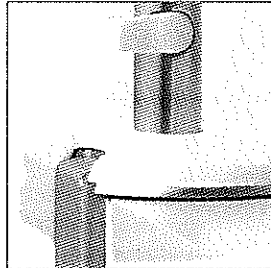

- Supports the vast majority of monitors in use today (up to 20 pounds)
- Interchangeable mounting options attach to a variety of work surfaces
- Integrated cable management hides cables within the arm
- Removable 180° stop protects walls and panels
- Optional Notebook Holder accommodates laptops 9" – 14" in length
- Optional 12" links provide greater adjustability and flexibility
- Arm reach: 20"
- Height adjustment range: 10"
- Weight: 5.7 pounds
- Finish options: Polished Aluminum with White accents or Silver with Gray accents
- Made primarily of steel and aluminum
- May contribute to a number of LEED credits
- 15-year 24/7 warranty

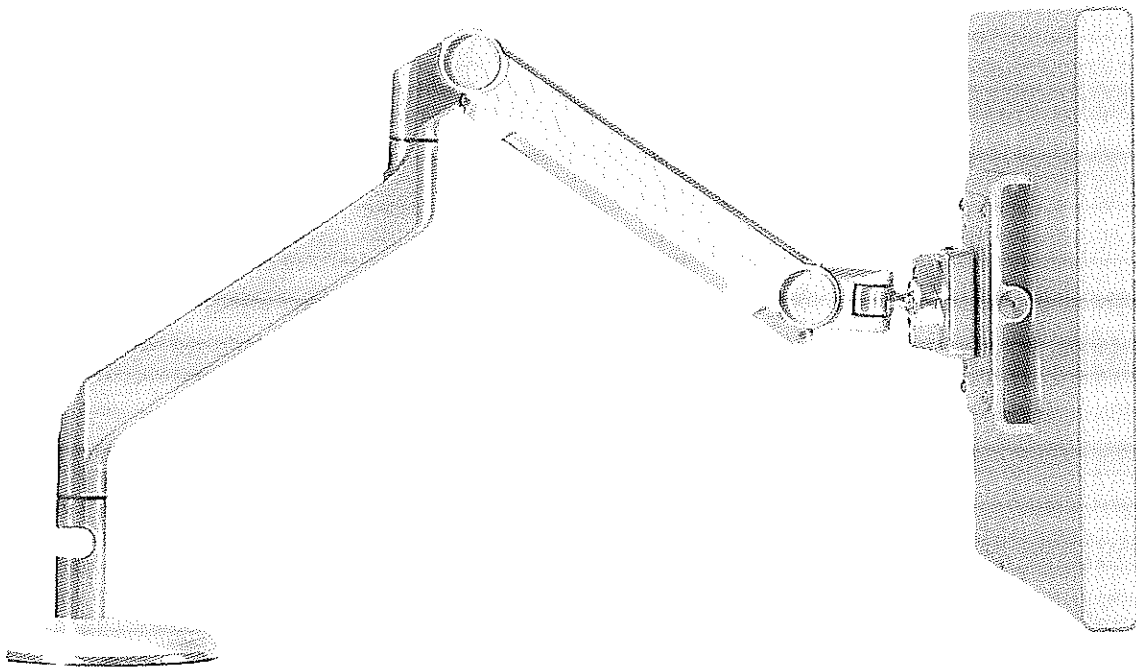

Creating a more comfortable place to work

www.humanscale.com
800.400.0625

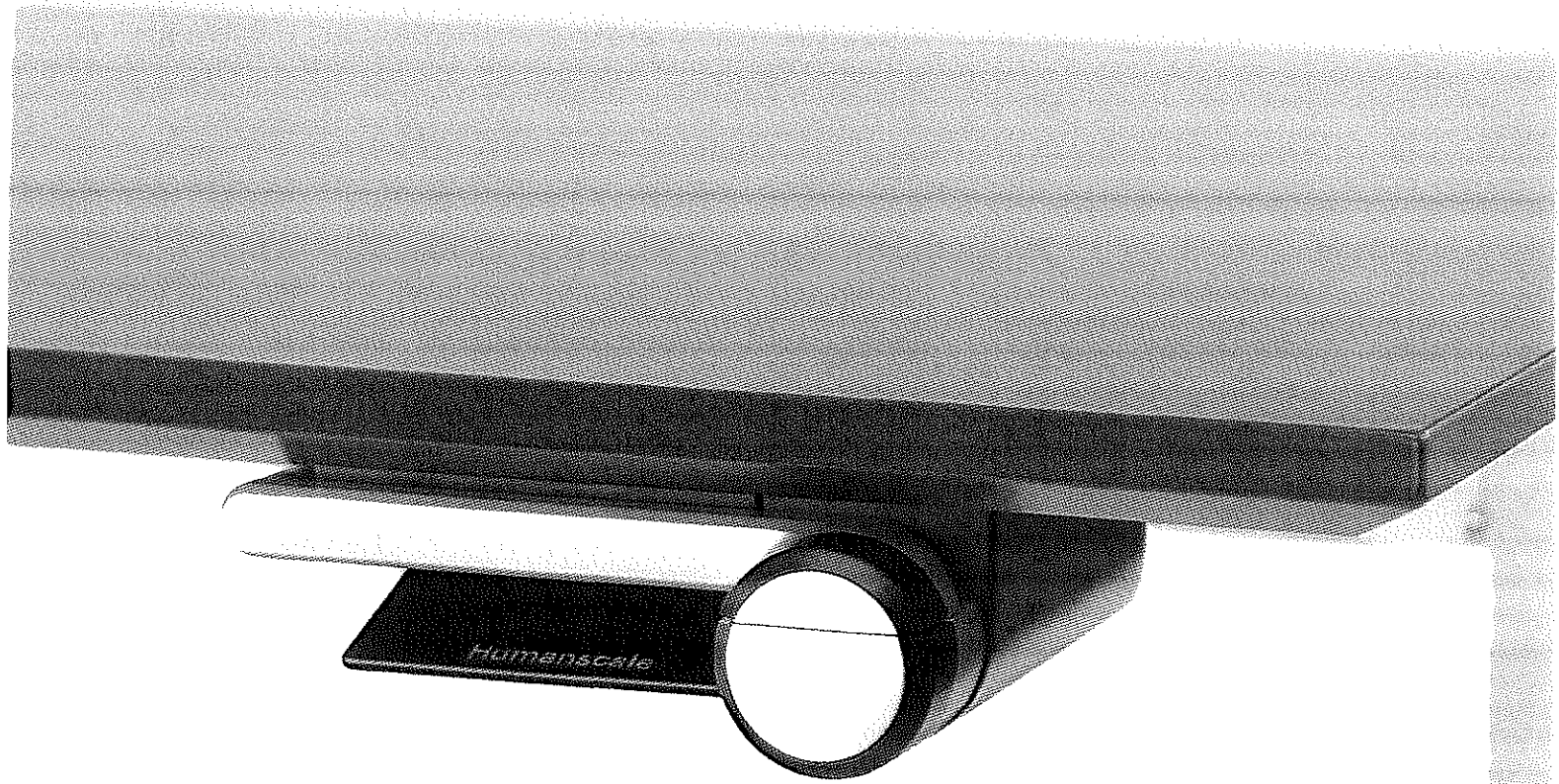

float®

Humanscale®

Introducing Float

The World's Most Revolutionary Height-Adjustable Table

Thanks to its innovative and proprietary design, the Float height-adjustable table solves the problems and limitations of current-generation sit/stand tables, gracefully adapting to a vast range of heights and weights with exceptional ease of use and safety features. Its ingenious counterbalance mechanism provides constant counter-weighting force that allows the table to move fluidly between sitting height and standing height, while accommodating the ergonomic needs of 99% of users.



The Dangers of Sedentary Work

While most office workers sit for the majority of their workdays, research shows that all-day sitting is a serious health risk. But standing all day at work isn't healthy either, causing discomfort and swelling in the legs and feet. Therefore, the most effective way to maintain health and comfort in the workplace is to alternate periodically between sitting and standing postures.

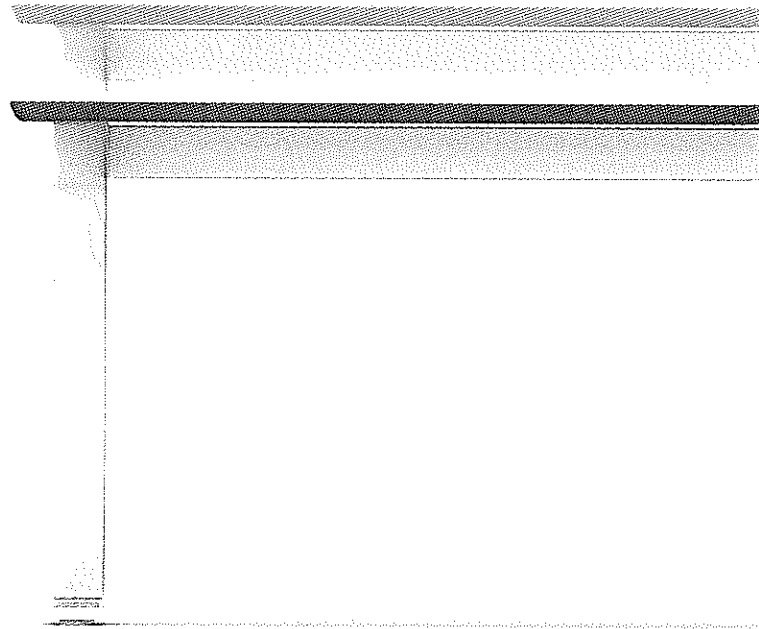

Features

- Unmatched performance and ease of use encourage desk-bound workers to regularly alternate between sitting and standing postures for long-term health
- Simple, single-handed weight adjustment instantly accommodates changes in tabletop weight
- Innovative safety features allows up or down adjustment only when the desktop and contents are properly counterbalanced
- With clean, architectural lines that belie its sophisticated functionality, the Float height-adjustable table complements any work environment while offering plenty of room under the work surface for legs, knees and feet
- Built for a long, serviceable life and limited carbon footprint, the Float height-adjustable table is made using minimal parts and manufacturing processes and is comprised predominantly of recyclable steel

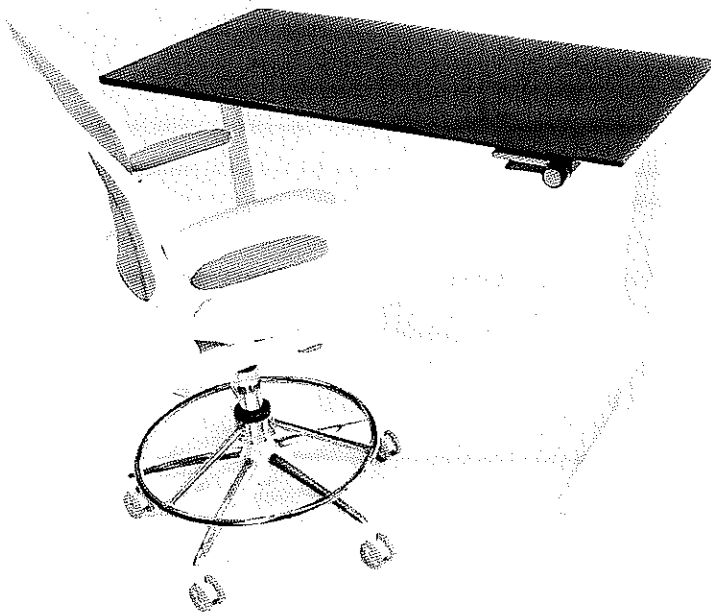

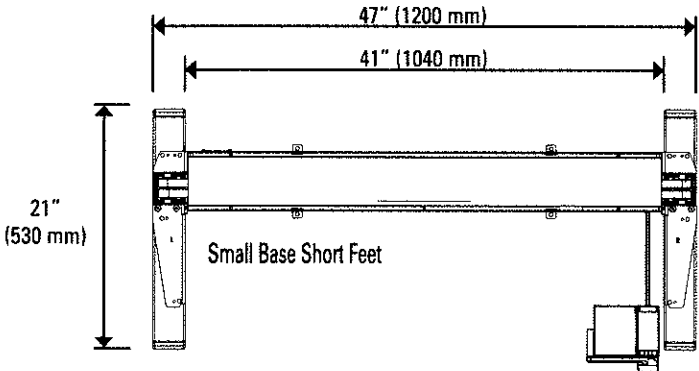
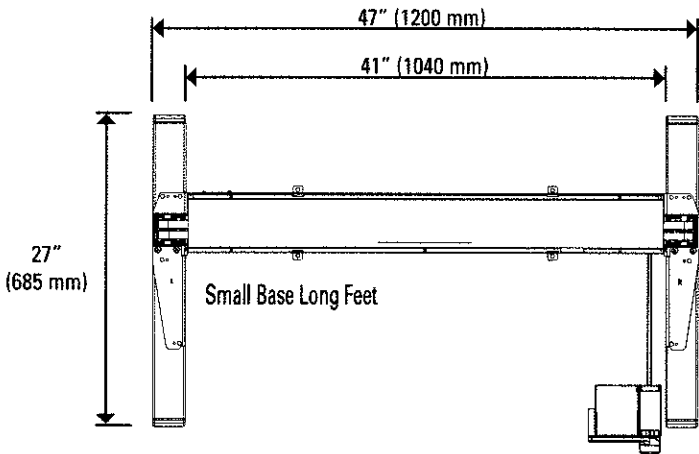
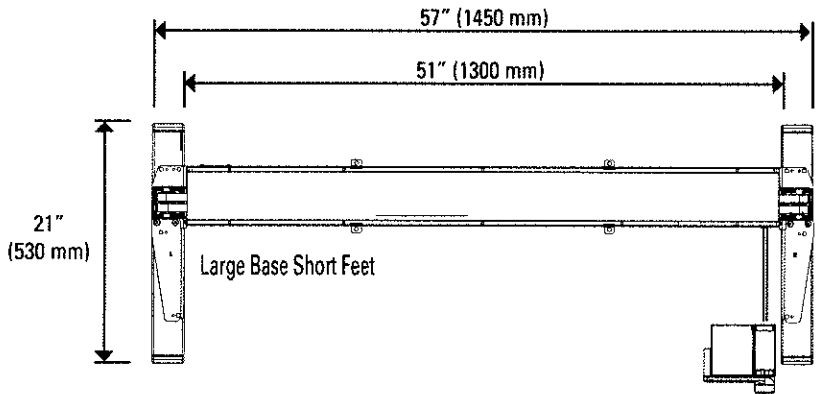
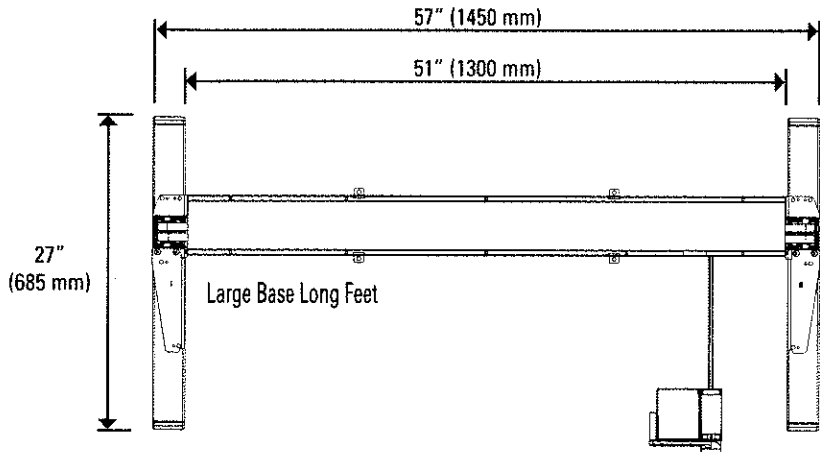

Specifications

- Provides an exceptional 20" of height adjustability (27" to 47" from the floor, excluding tabletop thickness)
- Counterbalances up to 130 lbs. of desktop weight (including the tabletop)
- Accommodates work surface widths from 48" (1200 mm) to 72" (1800 mm) and depths from 24" (600 mm) to 30" (800 mm), including work surfaces from most manufacturers
- Meets BIFMA requirements for load, capacity and stability
- Made from recyclable steel and aluminum
- Includes a 5-year, 24/7 warranty

Colors and Finishes

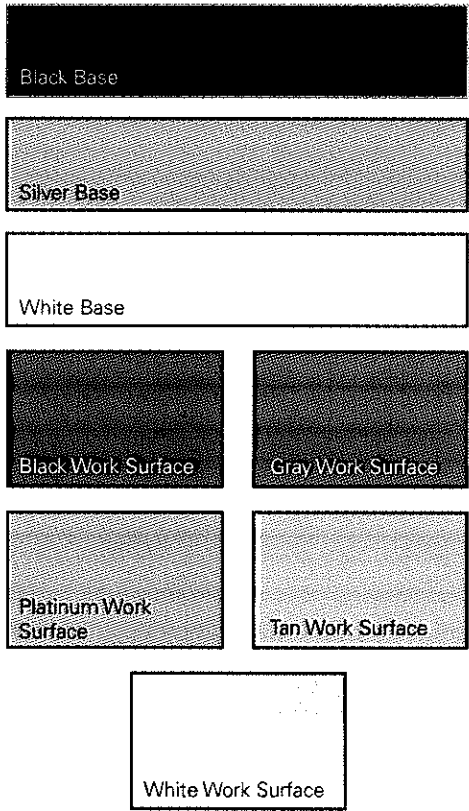



e float[®]

Humanscale[®]

eFloat brings effortless operation to sit/stand desks. Users can easily find the ideal height for health and comfort at the press of a button. Available with a low-profile analog touchpad, or a digital memory touchpad that can store up to four custom positions, eFloat's electric drive system is fast-moving, allows for noise-free height adjustment and has a built-in safety sensor. To enhance all-day comfort while sitting or standing, ergonomic tools can be easily mounted onto eFloat thanks to a uniquely expandable frame and stabilizer bar. Accommodating multiple desktop sizes and shapes, eFloat enhances the user experience and seamlessly integrates into any office or home environment.

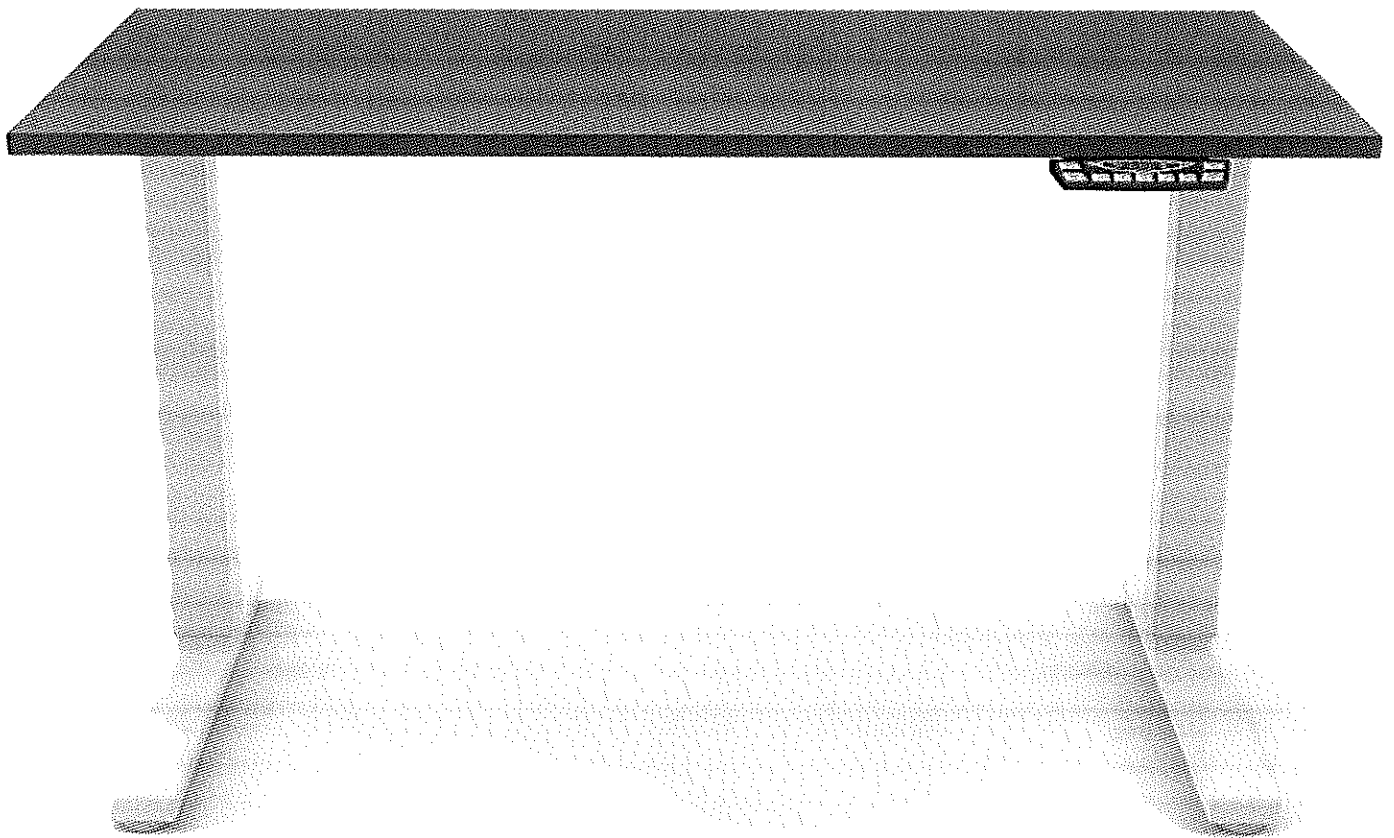

Features

- Encourages workers to regularly alternate between sitting and standing postures for long-term health
- Strong, expandable frame supports a variety of surface designs and ergonomic tools such as keyboard trays and monitor arms while offering plenty of room under the work surface for legs, knees and feet
- Innovative sensor safety feature stops table from bumping into objects when height is raised or lowered
- Sleek, clean design complements any work environment

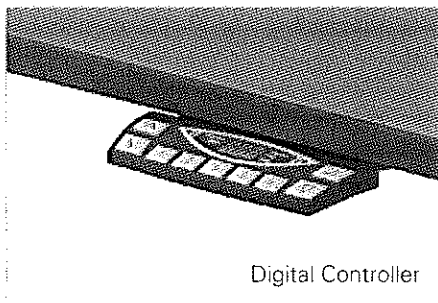
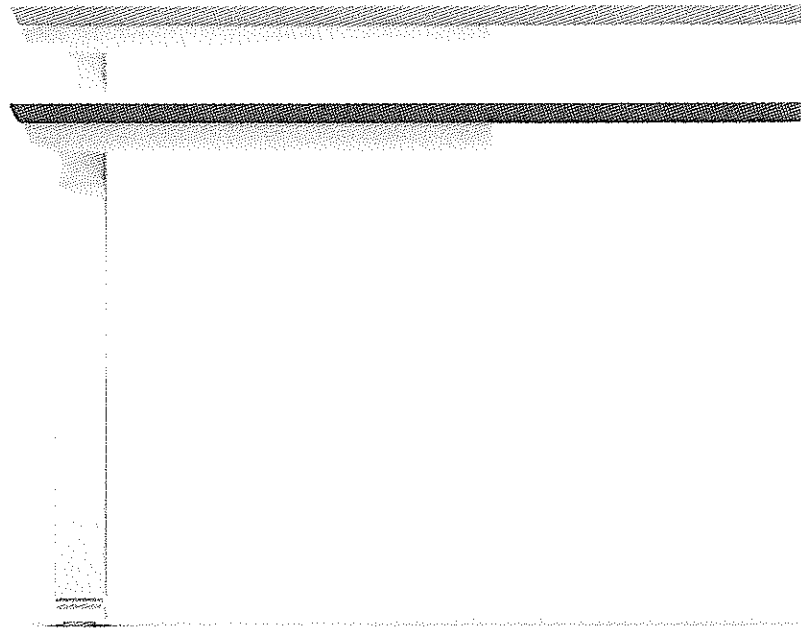

Digital Controller

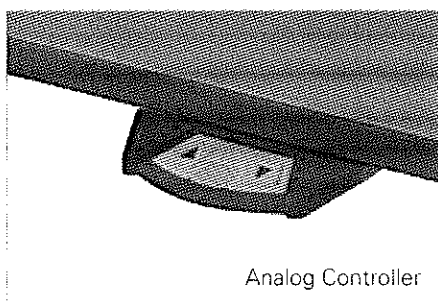

Analog Controller

Specifications

- Provides an exceptional 20" of height adjustability (27" to 47" from the floor, excluding tabletop thickness)
- Expandable upper frame. One frame width fits all surfaces (42" W to 72" W)
- Lifts up to 220 lbs. (including the tabletop)
- Accommodates work surface widths from 48" (1200 mm) to 72" (1800 mm) and depths from 24" (600 mm) to 30" (800 mm), including work surfaces from most manufacturers
- Meets BIFMA requirements for load, capacity and stability
- 5-year, 24/7 warranty

Environmental Story

Humanscale products are designed with a genuine focus on their environmental impact at every stage of their development.

For us, the best designs in the world achieve more with less, and sustainability is the natural result of this focus. eFloat table tops are certified as FSC Mix by the Forest Stewardship Council (FSC), and the bases are made with highly recyclable steel and aluminum parts.

QuickStand™

Strong, stylish and simple to use, the QuickStand height-adjustable workstation is built for the modern workplace.



Product Dimensions

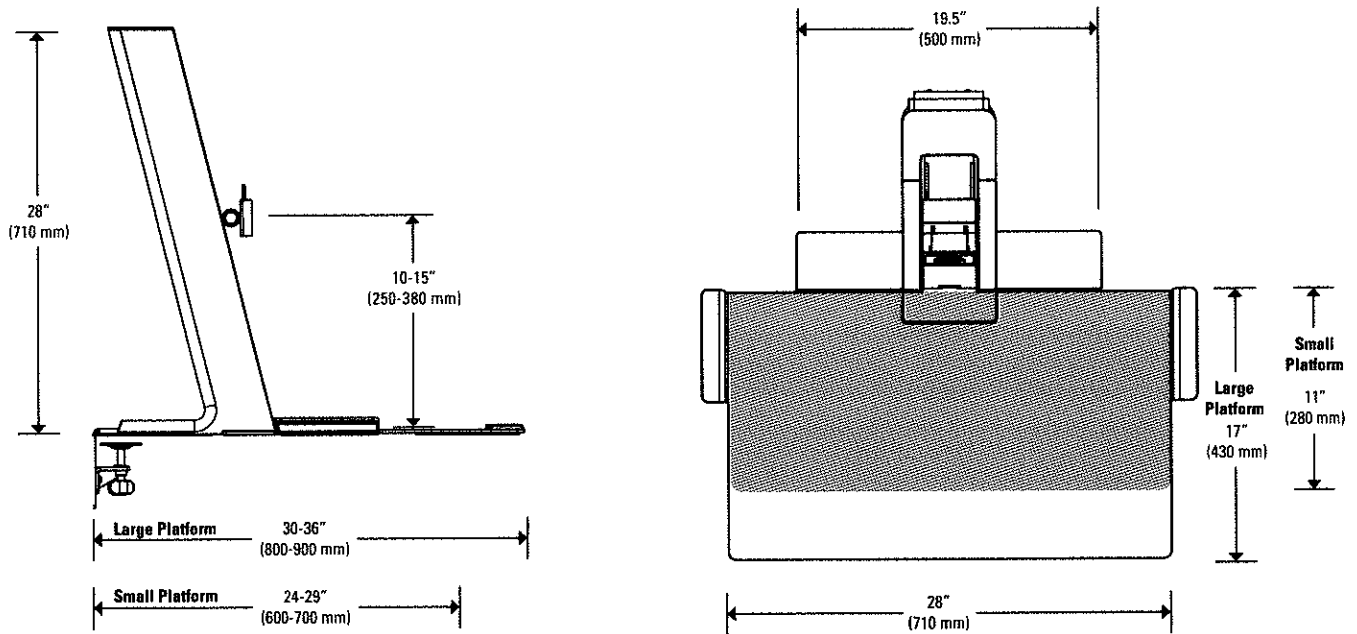

Side View

Top View

Color Options

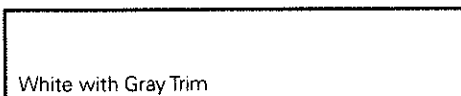
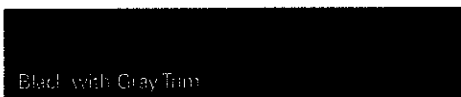

Specifications

- Cable harness pre-installed for easy plug in and go
- Fully integrated cable management
- Two USB outlets for keyboard/mouse
- 18" (460 mm) platform height adjustment
- 5" (127 mm) single/dual monitor display adjustment
- Work surface clamp has 6" (150 mm) of horizontal adjustment for a 24" (600 mm) up to 36" (900 mm) deep surface
- Work surface clamp attaches to the back edge of a ½" (13 mm) up to 2¾" (70 mm) thick surface

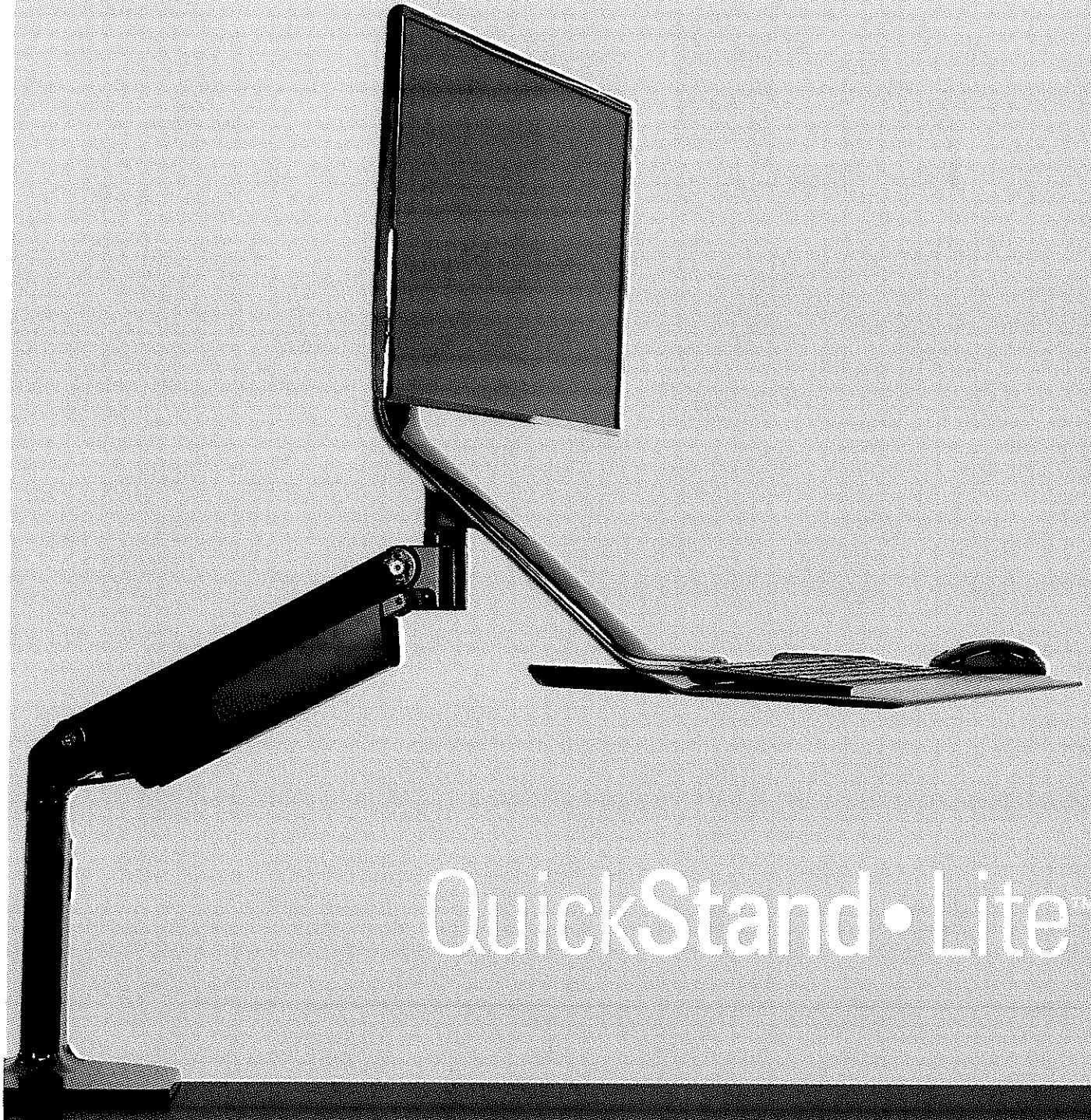

QuickStand • Lite™



Humanscale's QuickStand Lite transforms any fixed-height desk into an active one. Its minimalist aesthetic complements any office environment and supports a variety of hardware. An adjustable keyboard and monitor arm platform provides exceptional stability while typing. An innovative counterbalance mechanism enables users to transition from sitting to standing positions with ease and encourages more movement—creating a truly active workspace.

Design Story

Humanscale Design Studio's newest sit/stand innovation, QuickStand Lite, was created to provide even more flexibility with a minimal footprint. QuickStand Lite's sleek aesthetic complements any interior and easily retrofits to existing work surfaces.

QuickStand Lite is Ideal For:

- Home or corporate office workspaces
- Collaboration or hot-desking spaces
- Check-in areas



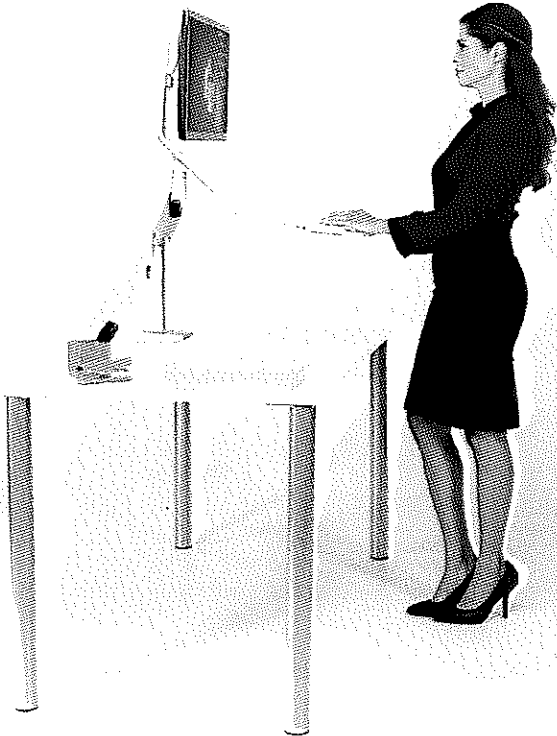

Features

- Main assembly holds single or dual monitors up to 25 lbs. of weight and can be converted to either configuration with minimal tools and components
- Designed to accommodate users of varying heights with 20" of total height range and 5.5" of vertical monitor adjustment
- Effortless functionality and flexibility encourages more movement and allows user to adjust position of QuickStand Lite as needed
- QuickStand Lite has a minimal footprint and can be attached to any fixed-height desk

Product Height	20" work surface level up
Product Radius	40"
Product Colors	White and Silver, Black on Black

Environmental Story

Humanscale products are designed with a constant and genuine focus on their environmental impact at every stage of their development. For us, the best designs in the world achieve more with less, and sustainability is the natural result of this focus. QuickStand Lite, like many of our products, is built with highly recyclable aluminum parts.

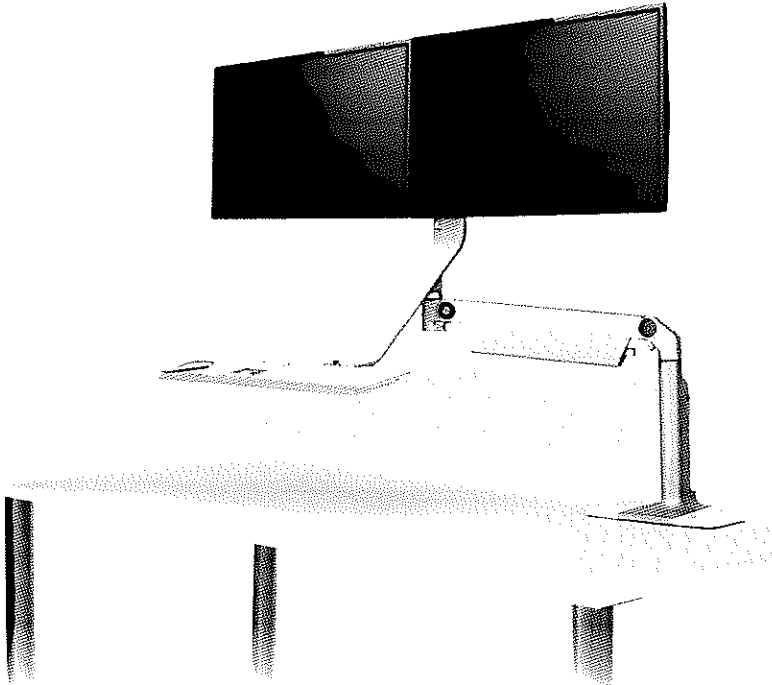



CERTIFICATE OF LIABILITY INSURANCE

DATE (MM/DD/YYYY)
8/3/2017

THIS CERTIFICATE IS ISSUED AS A MATTER OF INFORMATION ONLY AND CONFERS NO RIGHTS UPON THE CERTIFICATE HOLDER. THIS CERTIFICATE DOES NOT AFFIRMATIVELY OR NEGATIVELY AMEND, EXTEND OR ALTER THE COVERAGE AFFORDED BY THE POLICIES BELOW. THIS CERTIFICATE OF INSURANCE DOES NOT CONSTITUTE A CONTRACT BETWEEN THE ISSUING INSURER(S), AUTHORIZED REPRESENTATIVE OR PRODUCER, AND THE CERTIFICATE HOLDER.

IMPORTANT: If the certificate holder is an ADDITIONAL INSURED, the policy(ies) must have ADDITIONAL INSURED provisions or be endorsed. If SUBROGATION IS WAIVED, subject to the terms and conditions of the policy, certain policies may require an endorsement. A statement on this certificate does not confer rights to the certificate holder in lieu of such endorsement(s).

PRODUCER The Harry A. Koch Co. P.O. Box 45279 Omaha NE 68145-0279	CONTACT NAME: PHONE (A/C, No, Ext): 402-861-7000		FAX (A/C, No):
	E-MAIL ADDRESS:		
INSURER(S) AFFORDING COVERAGE			NAIC #
INSURER A: Travelers Indemnity Company			25658
INSURER B: Charter Oak Fire Insurance Co.			25615
INSURER C: The Phoenix Insurance Co			25623
INSURER D:			
INSURER E:			
INSURER F:			

COVERAGES **CERTIFICATE NUMBER:** 993161472 **REVISION NUMBER:**

THIS IS TO CERTIFY THAT THE POLICIES OF INSURANCE LISTED BELOW HAVE BEEN ISSUED TO THE INSURED NAMED ABOVE FOR THE POLICY PERIOD INDICATED. NOTWITHSTANDING ANY REQUIREMENT, TERM OR CONDITION OF ANY CONTRACT OR OTHER DOCUMENT WITH RESPECT TO WHICH THIS CERTIFICATE MAY BE ISSUED OR MAY PERTAIN, THE INSURANCE AFFORDED BY THE POLICIES DESCRIBED HEREIN IS SUBJECT TO ALL THE TERMS, EXCLUSIONS AND CONDITIONS OF SUCH POLICIES. LIMITS SHOWN MAY HAVE BEEN REDUCED BY PAID CLAIMS.

INSR LTR	TYPE OF INSURANCE	ADDL INSD	SUBR WVD	POLICY NUMBER	POLICY EFF (MM/DD/YYYY)	POLICY EXP (MM/DD/YYYY)	LIMITS
B	<input checked="" type="checkbox"/> COMMERCIAL GENERAL LIABILITY <input type="checkbox"/> CLAIMS-MADE <input checked="" type="checkbox"/> OCCUR <input checked="" type="checkbox"/> 2500 GEN'L AGGREGATE LIMIT APPLIES PER: <input checked="" type="checkbox"/> POLICY <input checked="" type="checkbox"/> PRO-JECT <input type="checkbox"/> LOC OTHER:			CO5355R886	8/6/2017	8/6/2018	EACH OCCURRENCE \$1000000 DAMAGE TO RENTED PREMISES (Ea occurrence) \$300000 MED EXP (Any one person) \$10000 PERSONAL & ADV INJURY \$1000000 GENERAL AGGREGATE \$2000000 PRODUCTS - COMP/OP AGG \$2000000 \$
C	<input checked="" type="checkbox"/> AUTOMOBILE LIABILITY <input checked="" type="checkbox"/> ANY AUTO <input type="checkbox"/> OWNED AUTOS ONLY <input type="checkbox"/> SCHEDULED AUTOS <input type="checkbox"/> HIRED AUTOS ONLY <input type="checkbox"/> NON-OWNED AUTOS ONLY			8105355R886	8/6/2017	8/6/2018	COMBINED SINGLE LIMIT (Ea accident) \$1000000 BODILY INJURY (Per person) \$ BODILY INJURY (Per accident) \$ PROPERTY DAMAGE (Per accident) \$ \$
A	<input checked="" type="checkbox"/> UMBRELLA LIAB <input checked="" type="checkbox"/> OCCUR <input type="checkbox"/> EXCESS LIAB <input type="checkbox"/> CLAIMS-MADE <input type="checkbox"/> DED <input checked="" type="checkbox"/> RETENTION \$ 10000			CUP5355R886	8/6/2017	8/6/2018	EACH OCCURRENCE \$9000000 AGGREGATE \$9000000 \$
C	<input checked="" type="checkbox"/> WORKERS COMPENSATION AND EMPLOYERS' LIABILITY ANY PROPRIETOR/PARTNER/EXECUTIVE OFFICER/MEMBER EXCLUDED? (Mandatory in NH) If yes, describe under DESCRIPTION OF OPERATIONS below	Y/N	N/A	UB2789C688	8/6/2017	8/6/2018	<input checked="" type="checkbox"/> PER STATUTE <input type="checkbox"/> OTH-ER E.L. EACH ACCIDENT \$1000000 E.L. DISEASE - EA EMPLOYEE \$1000000 E.L. DISEASE - POLICY LIMIT \$1000000

DESCRIPTION OF OPERATIONS / LOCATIONS / VEHICLES (ACORD 101, Additional Remarks Schedule, may be attached if more space is required)

City of Lincoln &/or Lancaster County &/or City of Lincoln/Lancaster County Public Building Commission are additional insured for general liability, including products and completed operations, and auto liability if required by written contract executed prior to loss.

The general liability, auto, and workers' compensation policies have been endorsed to provide 30 days notice of cancellation, except for cancellation for nonpayment of premium, in which case 10 days notice of cancellation will be provided.

Waiver of Subrogation applies for workers compensation if required by written contract executed prior to loss.

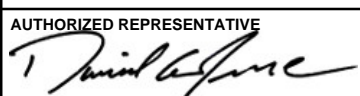
CERTIFICATE HOLDER City of Lincoln &/or Lancaster County &/or City of Lincoln/Lancaster County Public Building Commission 555 South 10th Street Lincoln NE 68508	CANCELLATION SHOULD ANY OF THE ABOVE DESCRIBED POLICIES BE CANCELLED BEFORE THE EXPIRATION DATE THEREOF, NOTICE WILL BE DELIVERED IN ACCORDANCE WITH THE POLICY PROVISIONS. AUTHORIZED REPRESENTATIVE 
--	--



ONE TOWER SQUARE
HARTFORD, CT 06183

**WORKERS COMPENSATION
AND
EMPLOYERS LIABILITY POLICY**

ENDORSEMENT WC 00 03 13 (00) -01

POLICY NUMBER: (DTNUB-2789C68-8)

WAIVER OF OUR RIGHT TO RECOVER FROM OTHERS ENDORSEMENT

We have the right to recover our payments from anyone liable for an injury covered by this policy. We will not enforce our right against the person or organization named in the Schedule. (This agreement applies only to the extent that you perform work under a written contract that requires you to obtain this agreement from us.)

This agreement shall not operate directly or indirectly to benefit any one not named in the Schedule.

SCHEDULE

DESIGNATED PERSON:

DESIGNATED ORGANIZATION:

**ANY PERSON OR ORGANIZATION FOR WHICH THE INSURED HAS
AGREED BY WRITTEN CONTRACT EXECUTED PRIOR TO LOSS TO
FURNISH THIS WAIVER.**

DATE OF ISSUE: 08-23-16

ST ASSIGN:

THIS ENDORSEMENT CHANGES THE POLICY. PLEASE READ IT CAREFULLY.

CONTRACTORS XTEND ENDORSEMENT

This endorsement modifies insurance provided under the following:

COMMERCIAL GENERAL LIABILITY COVERAGE PART

GENERAL DESCRIPTION OF COVERAGE – This endorsement broadens coverage. However, coverage for any injury, damage or medical expenses described in any of the provisions of this endorsement may be excluded or limited by another endorsement to this Coverage Part, and these coverage broadening provisions do not apply to the extent that coverage is excluded or limited by such an endorsement. The following listing is a general coverage description only. Limitations and exclusions may apply to these coverages. Read all the provisions of this endorsement and the rest of your policy carefully to determine rights, duties, and what is and is not covered.

- | | |
|--|---|
| <ul style="list-style-type: none"> A. Aircraft Chartered With Pilot B. Damage To Premises Rented To You C. Increased Supplementary Payments D. Incidental Medical Malpractice E. Who Is An Insured – Newly Acquired Or Formed Organizations F. Who Is An Insured – Broadened Named Insured – Unnamed Subsidiaries G. Blanket Additional Insured – Owners, Managers Or Lessors Of Premises | <ul style="list-style-type: none"> H. Blanket Additional Insured – Lessors Of Leased Equipment I. Blanket Additional Insured – States Or Political Subdivisions – Permits J. Knowledge And Notice Of Occurrence Or Offense K. Unintentional Omission L. Blanket Waiver Of Subrogation M. Amended Bodily Injury Definition N. Contractual Liability – Railroads |
|--|---|

PROVISIONS

A. AIRCRAFT CHARTERED WITH PILOT

The following is added to Exclusion **g.**, **Aircraft, Auto Or Watercraft**, in Paragraph 2. of **SECTION I – COVERAGES – COVERAGE A BODILY INJURY AND PROPERTY DAMAGE LIABILITY**:

This exclusion does not apply to an aircraft that is:

- (a) Chartered with a pilot to any insured;
- (b) Not owned by any insured; and
- (c) Not being used to carry any person or property for a charge.

B. DAMAGE TO PREMISES RENTED TO YOU

1. The first paragraph of the exceptions in Exclusion **j.**, **Damage To Property**, in Paragraph 2. of **SECTION I – COVERAGES – COVERAGE A BODILY INJURY AND PROPERTY DAMAGE LIABILITY** is deleted.
2. The following replaces the last paragraph of Paragraph 2., **Exclusions**, of **SECTION I – COVERAGES – COVERAGE A. BODILY**

INJURY AND PROPERTY DAMAGE LIABILITY:

Exclusions **c.** and **g.** through **n.** do not apply to "premises damage". Exclusion **f.(1)(a)** does not apply to "premises damage" caused by:

- a. Fire;
- b. Explosion;
- c. Lightning;
- d. Smoke resulting from such fire, explosion, or lightning; or
- e. Water;

unless Exclusion **f.** of Section **I – Coverage A – Bodily Injury And Property Damage Liability** is replaced by another endorsement to this Coverage Part that has Exclusion – All Pollution Injury Or Damage or Total Pollution Exclusion in its title.

A separate limit of insurance applies to "premises damage" as described in Paragraph 6. of **SECTION III – LIMITS OF INSURANCE**.



COMMERCIAL GENERAL LIABILITY

3. The following replaces Paragraph 6. of **SECTION III – LIMITS OF INSURANCE**:

Subject to 5. above, the Damage To Premises Rented To You Limit is the most we will pay under Coverage A for damages because of "premises damage" to any one premises. The Damage To Premises Rented To You Limit will apply to all "property damage" proximately caused by the same "occurrence", whether such damage results from: fire; explosion; lightning; smoke resulting from such fire, explosion, or lightning; or water; or any combination of any of these causes.

The Damage To Premises Rented To You Limit will be:

- a. The amount shown for the Damage To Premises Rented To You Limit on the Declarations of this Coverage Part; or
 - b. \$300,000 if no amount is shown for the Damage To Premises Rented To You Limit on the Declarations of this Coverage Part.
4. The following replaces Paragraph a. of the definition of "insured contract" in the **DEFINITIONS** Section:
- a. A contract for a lease of premises. However, that portion of the contract for a lease of premises that indemnifies any person or organization for "premises damage" is not an "insured contract";
5. The following is added to the **DEFINITIONS** Section:
- "Premises damage" means "property damage" to:
- a. Any premises while rented to you or temporarily occupied by you with permission of the owner; or
 - b. The contents of any premises while such premises is rented to you, if you rent such premises for a period of seven or fewer consecutive days.
6. The following replaces Paragraph 4.b.(1)(b) of **SECTION IV – COMMERCIAL GENERAL LIABILITY CONDITIONS**:
- (b) That is insurance for "premises damage"; or
7. Paragraph 4.b.(1)(c) of **SECTION IV – COMMERCIAL GENERAL LIABILITY CONDITIONS** is deleted.

C. INCREASED SUPPLEMENTARY PAYMENTS

1. The following replaces Paragraph 1.b. of **SUPPLEMENTARY PAYMENTS – COVERAGES A AND B** of **SECTION I – COVERAGE**:
 - b. Up to \$2,500 for the cost of bail bonds required because of accidents or traffic law violations arising out of the use of any vehicle to which the Bodily Injury Liability Coverage applies. We do not have to furnish these bonds.
2. The following replaces Paragraph 1.d. of **SUPPLEMENTARY PAYMENTS – COVERAGES A AND B** of **SECTION I – COVERAGES**:
 - d. All reasonable expenses incurred by the insured at our request to assist us in the investigation or defense of the claim or "suit", including actual loss of earnings up to \$500 a day because of time off from work.

D. INCIDENTAL MEDICAL MALPRACTICE

1. The following is added to the definition of "occurrence" in the **DEFINITIONS** Section:

"Occurrence" also means an act or omission committed in providing or failing to provide "incidental medical services", first aid or "Good Samaritan services" to a person.
2. The following is added to Paragraph 2.a.(1) of **SECTION II – WHO IS AN INSURED**:

Paragraph (1)(d) above does not apply to "bodily injury" arising out of providing or failing to provide:

 - (i) "Incidental medical services" by any of your "employees" who is a nurse practitioner, registered nurse, licensed practical nurse, nurse assistant, emergency medical technician or paramedic; or
 - (ii) First aid or "Good Samaritan services" by any of your "employees" or "volunteer workers", other than an employed or volunteer doctor. Any such "employees" or "volunteer workers" providing or failing to provide first aid or "Good Samaritan services" during their work hours for you will be deemed to be acting within the scope of their employment by you or performing duties related to the conduct of your business.

3. The following is added to Paragraph 5. of **SECTION III – LIMITS OF INSURANCE:**

For the purposes of determining the applicable Each Occurrence Limit, all related acts or omissions committed in providing or failing to provide "incidental medical services", first aid or "Good Samaritan services" to any one person will be deemed to be one "occurrence".

4. The following exclusion is added to Paragraph 2., **Exclusions**, of **SECTION I – COVERAGES – COVERAGE A BODILY INJURY AND PROPERTY DAMAGE LIABILITY:**

Sale Of Pharmaceuticals

"Bodily injury" or "property damage" arising out of the willful violation of a penal statute or ordinance relating to the sale of pharmaceuticals committed by, or with the knowledge or consent of, the insured.

5. The following is added to the **DEFINITIONS** Section:

"Incidental medical services" means:

- a. Medical, surgical, dental, laboratory, x-ray or nursing service or treatment, advice or instruction, or the related furnishing of food or beverages; or
- b. The furnishing or dispensing of drugs or medical, dental, or surgical supplies or appliances.

"Good Samaritan services" means any emergency medical services for which no compensation is demanded or received.

6. The following is added to Paragraph 4.b., **Excess Insurance**, of **SECTION IV – COMMERCIAL GENERAL LIABILITY CONDITIONS:**

The insurance is excess over any valid and collectible other insurance available to the insured, whether primary, excess, contingent or on any other basis, that is available to any of your "employees" or "volunteer workers" for "bodily injury" that arises out of providing or failing to provide "incidental medical services", first aid or "Good Samaritan services" to any person to the extent not subject to Paragraph 2.a.(1) of Section II – Who Is An Insured.

E. WHO IS AN INSURED – NEWLY ACQUIRED OR FORMED ORGANIZATIONS

The following replaces Paragraph 4. of **SECTION II – WHO IS AN INSURED:**

4. Any organization you newly acquire or form, other than a partnership, joint venture or limited liability company, of which you are the sole owner or in which you maintain the majority ownership interest, will qualify as a Named Insured if there is no other insurance which provides similar coverage to that organization. However:

a. Coverage under this provision is afforded only:

(1) Until the 180th day after you acquire or form the organization or the end of the policy period, whichever is earlier, if you do not report such organization in writing to us within 180 days after you acquire or form it; or

(2) Until the end of the policy period, when that date is later than 180 days after you acquire or form such organization, if you report such organization in writing to us within 180 days after you acquire or form it, and we agree in writing that it will continue to be a Named Insured until the end of the policy period;

b. Coverage A does not apply to "bodily injury" or "property damage" that occurred before you acquired or formed the organization; and

c. Coverage B does not apply to "personal injury" or "advertising injury" arising out of an offense committed before you acquired or formed the organization.

F. WHO IS AN INSURED – BROADENED NAMED INSURED – UNNAMED SUBSIDIARIES

The following is added to **SECTION II – WHO IS AN INSURED:**

Any of your subsidiaries, other than a partnership, joint venture or limited liability company, that is not shown as a Named Insured in the Declarations is a Named Insured if you maintain an ownership interest of more than 50% in such subsidiary on the first day of the policy period.

No such subsidiary is an insured for "bodily injury" or "property damage" that occurred, or "personal injury" or "advertising injury" caused by an offense committed after the date, if any, during the policy period, that you no longer maintain an ownership interest of more than 50% in such subsidiary.



G. BLANKET ADDITIONAL INSURED – OWNERS, MANAGERS OR LESSORS OF PREMISES

The following is added to **SECTION II – WHO IS AN INSURED**:

Any person or organization that is a premises owner, manager or lessor and that you have agreed in a written contract or agreement to include as an additional insured on this Coverage Part is an insured, but only with respect to liability for "bodily injury", "property damage", "personal injury" or "advertising injury" that:

- a. Is "bodily injury" or "property damage" that occurs, or is "personal injury" or "advertising injury" caused by an offense that is committed, subsequent to the execution of that contract or agreement; and
- b. Arises out of the ownership, maintenance or use of that part of any premises leased to you.

The insurance provided to such premises owner, manager or lessor is subject to the following provisions:

- a. The limits of insurance provided to such premises owner, manager or lessor will be the minimum limits which you agreed to provide in the written contract or agreement, or the limits shown on the Declarations, whichever are less.
- b. The insurance provided to such premises owner, manager or lessor does not apply to:
 - (1) Any "bodily injury" or "property damage" that occurs, or "personal injury" or "advertising injury" caused by an offense that is committed, after you cease to be a tenant in that premises; or
 - (2) Structural alterations, new construction or demolition operations performed by or on behalf of such premises owner, lessor or manager.
- c. The insurance provided to such premises owner, manager or lessor is excess over any valid and collectible other insurance available to such premises owner, manager or lessor, whether primary, excess, contingent or on any other basis, unless you have agreed in the written contract or agreement that this insurance must be primary to, or non-contributory with, such other insurance, in which case this insurance will be primary to, and non-contributory with, such other insurance.

H. BLANKET ADDITIONAL INSURED – LESSORS OF LEASED EQUIPMENT

The following is added to **SECTION II – WHO IS AN INSURED**:

Any person or organization that is an equipment lessor and that you have agreed in a written contract or agreement to include as an insured on this Coverage Part is an insured, but only with respect to liability for "bodily injury", "property damage", "personal injury" or "advertising injury" that:

- a. Is "bodily injury" or "property damage" that occurs, or is "personal injury" or "advertising injury" caused by an offense that is committed, subsequent to the execution of that contract or agreement; and
- b. Is caused, in whole or in part, by your acts or omissions in the maintenance, operation or use of equipment leased to you by such equipment lessor.

The insurance provided to such equipment lessor is subject to the following provisions:

- a. The limits of insurance provided to such equipment lessor will be the minimum limits which you agreed to provide in the written contract or agreement, or the limits shown on the Declarations, whichever are less.
- b. The insurance provided to such equipment lessor does not apply to any "bodily injury" or "property damage" that occurs, or "personal injury" or "advertising injury" caused by an offense that is committed, after the equipment lease expires.
- c. The insurance provided to such equipment lessor is excess over any valid and collectible other insurance available to such equipment lessor, whether primary, excess, contingent or on any other basis, unless you have agreed in the written contract or agreement that this insurance must be primary to, or non-contributory with, such other insurance, in which case this insurance will be primary to, and non-contributory with, such other insurance.

I. BLANKET ADDITIONAL INSURED – STATES OR POLITICAL SUBDIVISIONS – PERMITS

The following is added to **SECTION II – WHO IS AN INSURED**:

Any state or political subdivision that has issued a permit in connection with operations performed by you or on your behalf and that you are required

by any ordinance, law or building code to include as an additional insured on this Coverage Part is an insured, but only with respect to liability for "bodily injury", "property damage", "personal injury" or "advertising injury" arising out of such operations.

The insurance provided to such state or political subdivision does not apply to:

- a. Any "bodily injury," "property damage," "personal injury" or "advertising injury" arising out of operations performed for that state or political subdivision; or
- b. Any "bodily injury" or "property damage" included in the "products-completed operations hazard".

J. KNOWLEDGE AND NOTICE OF OCCURRENCE OR OFFENSE

The following is added to Paragraph 2., **Duties In The Event of Occurrence, Offense, Claim or Suit**, of **SECTION IV – COMMERCIAL GENERAL LIABILITY CONDITIONS**:

- e. The following provisions apply to Paragraph a. above, but only for the purposes of the insurance provided under this Coverage Part to you or any insured listed in Paragraph 1. or 2. of Section II – Who Is An Insured:

- (1) Notice to us of such "occurrence" or offense must be given as soon as practicable only after the "occurrence" or offense is known by you (if you are an individual), any of your partners or members who is an individual (if you are a partnership or joint venture), any of your managers who is an individual (if you are a limited liability company), any of your "executive officers" or directors (if you are an organization other than a partnership, joint venture or limited liability company) or any "employee" authorized by you to give notice of an "occurrence" or offense.

- (2) If you are a partnership, joint venture or limited liability company, and none of your partners, joint venture members or managers are individuals, notice to us of such "occurrence" or offense must be given as soon as practicable only after the "occurrence" or offense is known by:

- (a) Any individual who is:
 - (i) A partner or member of any partnership or joint venture;

- (ii) A manager of any limited liability company; or
- (iii) An executive officer or director of any other organization;

that is your partner, joint venture member or manager; or

- (b) Any "employee" authorized by such partnership, joint venture, limited liability company or other organization to give notice of an "occurrence" or offense.

- (3) Notice to us of such "occurrence" or of an offense will be deemed to be given as soon as practicable if it is given in good faith as soon as practicable to your workers' compensation insurer. This applies only if you subsequently give notice to us of the "occurrence" or offense as soon as practicable after any of the persons described in Paragraphs e. (1) or (2) above discovers that the "occurrence" or offense may result in sums to which the insurance provided under this Coverage Part may apply.

However, if this Coverage Part includes an endorsement that provides limited coverage for "bodily injury" or "property damage" or pollution costs arising out of a discharge, release or escape of "pollutants" which contains a requirement that the discharge, release or escape of "pollutants" must be reported to us within a specific number of days after its abrupt commencement, this Paragraph e. does not affect that requirement.

K. UNINTENTIONAL OMISSION

The following is added to Paragraph 6., **Representations**, of **SECTION IV – COMMERCIAL GENERAL LIABILITY CONDITIONS**:

The unintentional omission of, or unintentional error in, any information provided by you which we relied upon in issuing this policy will not prejudice your rights under this insurance. However, this provision does not affect our right to collect additional premium or to exercise our rights of cancellation or nonrenewal in accordance with applicable insurance laws or regulations.

L. BLANKET WAIVER OF SUBROGATION

The following is added to Paragraph 8., **Transfer Of Rights Of Recovery Against Others To Us**, of **SECTION IV – COMMERCIAL GENERAL LIABILITY CONDITIONS**:



COMMERCIAL GENERAL LIABILITY

If the insured has agreed in a contract or agreement to waive that insured's right of recovery against any person or organization, we waive our right of recovery against such person or organization, but only for payments we make because of:

- a. "Bodily injury" or "property damage" that occurs; or
- b. "Personal injury" or "advertising injury" caused by an offense that is committed;

subsequent to the execution of that contract or agreement.

M. AMENDED BODILY INJURY DEFINITION

The following replaces the definition of "bodily injury" in the **DEFINITIONS** Section:

3. "Bodily injury" means bodily injury, mental anguish, mental injury, shock, fright, disability, humiliation, sickness or disease sustained by a person, including death resulting from any of these at any time.

N. CONTRACTUAL LIABILITY – RAILROADS

1. The following replaces Paragraph c. of the definition of "insured contract" in the **DEFINITIONS** Section:
 - c. Any easement or license agreement;
2. Paragraph f.(1) of the definition of "insured contract" in the **DEFINITIONS** Section is deleted.

THIS ENDORSEMENT CHANGES THE POLICY. PLEASE READ IT CAREFULLY.

BLANKET ADDITIONAL INSURED – PRIMARY AND NON-CONTRIBUTORY WITH OTHER INSURANCE

This endorsement modifies insurance provided under the following:

BUSINESS AUTO COVERAGE FORM

PROVISIONS

1. The following is added to Paragraph A.1.c., **Who Is An Insured**, of **SECTION II – COVERED AUTOS LIABILITY COVERAGE**:

Any person or organization who is required under a written contract or agreement between you and that person or organization, that is signed and executed by you before the "bodily injury" or "property damage" occurs and that is in effect during the policy period, to be named as an additional insured is an "insured" for Covered Autos Liability Coverage, but only for damages to which this insurance applies and only to the extent that person or organization qualifies as an "insured" under the Who Is An Insured provision contained in **SECTION II**.

2. The following is added to Paragraph B.5., **Other Insurance** of **SECTION IV – BUSINESS AUTO CONDITIONS**:

Regardless of the provisions of paragraph a. and paragraph d. of this part **5. Other Insurance**, this insurance is primary to and non-contributory with applicable other insurance under which an additional insured person or organization is the first named insured when the written contract or agreement between you and that person or organization, that is signed and executed by you before the "bodily injury" or "property damage" occurs and that is in effect during the policy period, requires this insurance to be primary and non-contributory.

THIS ENDORSEMENT CHANGES THE POLICY. PLEASE READ IT CAREFULLY

BLANKET ADDITIONAL INSURED (CONTRACTORS)

This endorsement modifies insurance provided under the following:

COMMERCIAL GENERAL LIABILITY COVERAGE PART

1. WHO IS AN INSURED – (Section II) is amended to include any person or organization that you agree in a "written contract requiring insurance" to include as an additional insured on this Coverage Part, but:
 - a) Only with respect to liability for "bodily injury", "property damage" or "personal injury"; and
 - b) If, and only to the extent that, the injury or damage is caused by acts or omissions of you or your subcontractor in the performance of "your work" to which the "written contract requiring insurance" applies. The person or organization does not qualify as an additional insured with respect to the independent acts or omissions of such person or organization.
2. The insurance provided to the additional insured by this endorsement is limited as follows:
 - a) In the event that the Limits of Insurance of this Coverage Part shown in the Declarations exceed the limits of liability required by the "written contract requiring insurance", the insurance provided to the additional insured shall be limited to the limits of liability required by that "written contract requiring insurance". This endorsement shall not increase the limits of insurance described in Section III – Limits Of Insurance.
 - b) The insurance provided to the additional insured does not apply to "bodily injury", "property damage" or "personal injury" arising out of the rendering of, or failure to render, any professional architectural, engineering or surveying services, including:
 - i. The preparing, approving, or failing to prepare or approve, maps, shop drawings, opinions, reports, surveys, field orders or change orders, or the preparing, approving, or failing to prepare or approve, drawings and specifications; and
 - ii. Supervisory, inspection, architectural or engineering activities.
3. The insurance provided to the additional insured by this endorsement is excess over any valid and collectible "other insurance", whether primary, excess, contingent or on any other basis, that is available to the additional insured for a loss we cover under this endorsement. However, if the "written contract requiring insurance" specifically requires that this insurance apply on a primary basis or a primary and non-contributory basis, this insurance is primary to "other insurance" available to the additional insured which covers that person or organization as a named insured for such loss, and we will not share with that "other insurance". But the insurance provided to the additional insured by this endorsement still is excess over any valid and collectible "other insurance", whether primary, excess, contingent or on any other basis, that is available to the additional insured when that person or organization is an additional insured under such "other insurance".
4. As a condition of coverage provided to the additional insured by this endorsement:
 - a) The additional insured must give us written notice as soon as practicable of an "occurrence" or an offense which may result in a claim. To the extent possible, such notice should include:
 - c) The insurance provided to the additional insured does not apply to "bodily injury" or "property damage" caused by "your work" and included in the "products-completed operations hazard" unless the "written contract requiring insurance" specifically requires you to provide such coverage for that additional insured, and then the insurance provided to the additional insured applies only to such "bodily injury" or "property damage" that occurs before the end of the period of time for which the "written contract requiring insurance" requires you to provide such coverage or the end of the policy period, whichever is earlier.



COMMERCIAL GENERAL LIABILITY

- i. How, when and where the "occurrence" or offense took place;
 - ii. The names and addresses of any injured persons and witnesses; and
 - iii. The nature and location of any injury or damage arising out of the "occurrence" or offense.
- b)** If a claim is made or "suit" is brought against the additional insured, the additional insured must:
- i. Immediately record the specifics of the claim or "suit" and the date received; and
 - ii. Notify us as soon as practicable.
- The additional insured must see to it that we receive written notice of the claim or "suit" as soon as practicable.
- c)** The additional insured must immediately send us copies of all legal papers received in connection with the claim or "suit", cooperate with us in the investigation or settlement of the claim or defense against the "suit", and otherwise comply with all policy conditions.
- d)** The additional insured must tender the defense and indemnity of any claim or "suit" to

any provider of "other insurance" which would cover the additional insured for a loss we cover under this endorsement. However, this condition does not affect whether the insurance provided to the additional insured by this endorsement is primary to "other insurance" available to the additional insured which covers that person or organization as a named insured as described in paragraph 3. above.

- 5.** The following definition is added to SECTION V. – DEFINITIONS:

"Written contract requiring insurance" means that part of any written contract or agreement under which you are required to include a person or organization as an additional insured on this Coverage Part, provided that the "bodily injury" and "property damage" occurs and the "personal injury" is caused by an offense committed:

- a. After the signing and execution of the contract or agreement by you;
- b. While that part of the contract or agreement is in effect; and
- c. Before the end of the policy period.

Commercial General Liability - Contractors

ISO Simplified Commercial General Liability Coverage Form

Coverage		Limits
Aggregate Limits of Liability	General Aggregate (Other than Products/Completed Operations)	\$2,000,000
	Products/Completed Operations Aggregate	\$2,000,000
Personal & Advertising Injury Liability	Each Person (Subject to General Aggregate)	\$1,000,000
Each Occurrence Limit	Combined Single Limit Bodily Injury & Property Damage (Subject to Products/Completed Operations and General Aggregate)	\$1,000,000
Damage To Premises Rented To You Limit	Any One Premises	\$300,000
Medical Expense Limit	Any One Person	\$10,000

Liability Deductible	Deductible Amount	Loss Type
Property Damage Deductible	\$2,500 Prod/Compl Ops and Prem/Ops	Loss and ALAE

Coverage A Bodily Injury and Property Damage Liability

Premises/Operations
 Products/Completed Operations
 Contractual Liability
 Liquor Liability
 Non-Owned Watercraft
 Damage To Premises Rented To You
 Employees as Insureds
 Incidental Medical Malpractice - Named Insured
 Limited Worldwide Products Liability
 Newly Acquired or Formed Organizations - 180 Days

Coverage B Personal and Advertising Injury Liability**Coverage C Medical Payments****Contractors Liability Program Highlights**

Aircraft Chartered With Pilot
 Damage To Premises Rented To You Extension
 · Perils if fire, explosion, lightning, smoke, water
 · Limit increase to \$300,000
 Increased Supplementary Payments
 · Cost for bail bonds increased to \$2,500

Consult Policy for Actual Terms and Conditions

- Loss of earnings increased to \$500 per day
- Incidental Medical Malpractice
Who Is An Insured – Newly Acquired Or Formed Organizations
Who Is An Insured - Broadened Named Insured – Unnamed Subsidiaries
Blanket Additional Insured – Owners, Managers or Lessors of Premises
Blanket Additional Insured – Lessors Of Leased Equipment
Blanket Additional Insured - States or Political Subdivisions – Permits
Knowledge and Notice of Occurrence or Offense
Unintentional Omission
Blanket Waiver of Subrogation
Amended Bodily Injury Definition
Contractual Liability - Railroads

Consult Policy for Actual Terms and Conditions



Commercial General Liability Forms

COMMERCIAL GENERAL LIABILITY COV FORM	CG 00 01
TEXAS CHANGES	CG 01 03
NEW YORK CHANGES-PREMIUM AUDIT	CG 01 04
KS AND OK CHANGES-TRANSFER OF RIGHTS	CG 01 09
MN CHANGES - CONTRACTUAL LIABILITY EXCL	CG 01 22
WI CHANGES-AMEND OF POLICY CONDITIONS	CG 01 24
SOUTH DAKOTA CHANGES	CG 01 44
MICHIGAN CHANGES	CG 01 68
UTAH CHANGES	CG 01 86
MINNESOTA CHANGES	CG 26 05
NY CHANGES-TRANSFER OF DUTIES	CG 26 21
MO CHANGES-GUARANTY ASSOCIATION	CG 26 25
MINNESOTA CHANGES - DUTIES CONDITION	CG 26 81
EXCLUSION-LEAD	CG D0 76
EXCLUSION-DISCRIMINATION	CG D1 42
COV FOR BI-CO-EMPLOY OR OTHER VOLUNTEER	CG D1 54
AMEND-POLL EXCL-INCL LTD COV POLL COST	CG D1 73
AMEND-NON CUMULATION OF EACH OCC	CG D2 03
EXCL-EXTERIOR INSULATION & FINISH SYSTEM	CG D2 04
DESIGNATED PROJECTS(S) GEN AGGR LIMIT	CG D2 11
EXCLUSION -SILICA OR SILICA-RELATED DUST	CG D2 40
EXCLUSION - WAR	CG D2 42
FUNGI OR BACTERIA EXCLUSION	CG D2 43
BLANKET ADDITIONAL INSURED (CONTRACTORS)	CG D2 46
ADD'L INS ENGS, ARCHITECTS, SURVEYORS	CG D2 70
EMPLOYMENT-RELATED PRACTICES EXCLUSION	CG D2 88
EXCL-CONSTR MAN ERRORS AND OMISSIONS	CG D2 93
DEDUCTIBLE LIABILITY INSURANCE	CG D3 05
CONTRACTORS XTEND ENDORSEMENT	CG D3 16
EXCL-SUITS ONE NAMED INS AGAINST ANOTHER	CG D3 22
EXCLUSION - UNSOLICITED COMMUNICATION	CG D3 26
MOBILE EQUIP REDEFINED-EXCL OF VEHICLES	CG D3 56
EXCL-PROJ SUBJ TO WRAP-UP-LTD EXCEPTIONS	CG D3 91
AMEND OTHER INS COND MEAN OTHER INS/INSR	CG D4 20
AMEND COVERAGE B - PERS & ADV INJURY	CG D4 71
EXCL - ARCHITECT/ENG/SURVEY PROF SERV	CG D5 46
EXCL-VIOLATION OF CONSUMER FIN PROT LAWS	CG D6 18
EXCL-ACCESS OR DISCL OF CONF/PERS INFO	CG D7 46
INDIANA CHANGES-DEFINITION OF POLLUTANTS	CG F1 19
MISSOURI CHGS - DEFINITION OF POLLUTANTS	CG F2 50
NEW YORK CHGS - CGL COVERAGE FORM	CG F2 63
COMM'L GENERAL LIABILITY DEC	CG T0 01
DECLARATIONS PREMIUM SCHEDULE	CG T0 07
KEY TO DECLARATIONS PREMIUM SCHEDULE	CG T0 08
EMPLOYEE BENEFITS LIAB COV PART DEC	CG T0 09
TABLE OF CONTENTS	CG T0 34
EMPLOYEE BENEFITS LIAB TABLE OF CONTENTS	CG T0 43
EMPLOYEE BENEFITS LIABILITY COV FORM	CG T1 01
EXCLUSION-ASBESTOS	CG T4 78
EXC-HAZARD-CONNECTED DESIGNATED EXPOSURE	CG T4 81
NUCLEAR ENERGY LIABILITY EXCLUSION	IL 00 21
COMMON POLICY CONDITIONS	IL T0 01
DESIGNATED ENTITY - NOC PROV BY US - 30 DAYS	IL T4 05
AMNDT COMMON POLICY COND-PROHIBITED COVG	IL T4 12
CAP ON LOSSES CERTIFIED ACT OF TERRORISM	IL T4 14

Consult Policy for Actual Terms and Conditions



Page 18

Date of Proposal:

Print Date: 07/24/17

Commercial Automobile

ISO Business Automobile Coverage Form

Coverage	Auto Symbols	Limits
Liability	1	\$1,000,000 any one accident
Medical Payments	2	\$10,000 Each Insured
Um Bi & Pd/Underinsured Motorist	2	As Elected. Named Insured will be required to complete Uninsured and Underinsured election forms (for all states that have an election form), prior to the effective date of the policy.
Comprehensive	8, 10	ACV less deductible
Collision	8, 11	ACV less deductible

Deductible Schedule

Vehicle Type	Comprehensive	Collision
Private Passenger	\$1,000	\$1,000
Light Truck	\$1,000	\$1,000
Medium Truck	\$1,000	\$1,000
Heavy Truck	\$1,000	\$1,000
Trailer	\$1,000	\$1,000

Amendments:

COLLISION COVERAGE APPLIES TO ALL OWNED AUTOS EXCEPT:

1999	FORD ECONOLINE VAN	1FTPE24LOXHA30627
2000	FORD ECONOLINE VAN	1FTNE24LXYHA50070

COMPREHENSIVE COVERAGE APPLIES TO ALL OWNED AUTOS EXCEPT:

1999	FORD ECONOLINE VAN	1FTPE24LOXHA30627
2000	FORD ECONOLINE VAN	1FTNE24LXYHA50070

Consult Policy for Actual Terms and Conditions

• HIRED CAR PHYSICAL DAMAGE		CA T0 03
	ESTIMATED ANNUAL COST OF HIRE	\$50,000
	COMPREHENSIVE DEDUCTIBLE	\$1,000
	COLLISION DEDUCTIBLE	\$1,000
• LESSOR – ADDITIONAL INSURED AND LOSS PAYEE		CA 20 01
	“ADDITIONAL INSURED (LESSOR)”: ANY "AUTO" LEASED FOR A PERIOD OF SIX MONTHS OR MORE UNDER A LEASING CONTRACT OR AGREEMENT THAT REQUIRES YOU TO PROVIDE DIRECT PRIMARY INSURANCE FOR THE LESSOR.	
• LOSS PAYABLE CLAUSE - BLANKET LOSS PAYEE		CA T4 45
• COMMON POLICY CONDITIONS		IL T0 01
• END FOR MC POL OF INS FOR PUBLIC LIAB		MCS90
• COVERAGE FOR CERTAIN OPERATIONS IN CONNECTION		CA 20 70
• BA/AD/MC COV PART SUPPL SCH - ITEM TWO		CA T0 30
• SHRT TRM HRD AUTO - ADDT'L INSD LS PAYEE		CA T4 52
• AMENDMENT OF EMPLOYEE DEFINITION		CA T4 59
• BLANKET ADDITIONAL INSURED – PRIMARY AND NONCONTRIBUTORY WITH OTHER INSURANCE		CA T4 74
• BUSINESS AUTO COVERAGE FORM		CA 00 01
• FELLOW EMPLOYEE COVERAGE		CA 20 55
• NE UM AND UIM COVERAGE		CA 21 70
• POLL LIAB-BUS AUTO/MOTOR CARRIER COV FRM		CA 99 48
• DESIGNATED ENTITY - NOC PROV BY US - 30 DAYS		IL T4 05
• AMNDT COMMON POLICY COND-PROHIBITED COVG		IL T4 12
• NUCLEAR ENERGY LIABILITY EXCL		IL 00 21

Consult Policy for Actual Terms and Conditions

- **BUSINESS AUTO EXTENSION ENDORSEMENT**
 - A. Broad Form Named Insured
 - B. Blanket Additional Insured
 - C. Employee Hired Auto
 - D. Employees As Insured
 - E. Supplementary Payments- Increased Limits
 - F. Hired Auto – Limited Worldwide Coverage – Indemnity Basis
 - G. Waiver Of Deductible – Glass
 - H. Hired Auto Physical Damage – Loss Of Use – Increased Limit
 - I. Physical Damage – Transportation Expenses – Increased Limit
 - J. Personal Property
 - K. Airbags
 - L. Notice And Knowledge Of Accident Or Loss
 - M. Blanket Waiver Of Subrogation
 - N. Unintentional Errors Or Omissions

Rating Schedule

Vehicle Type	Liability		Physical Damage			
	# of Vehs	Rate	Comprehensive		Collision	
# of Vehs			Rate	# of Vehs	Rate	
Private Passenger	1		1		1	
Light Truck	24		22		22	
Medium Truck	1		1		1	
Heavy Truck	3		3		3	
Trailer	8		8		8	
Total # of Vehs	37		35		35	
Total Premium						

Miscellaneous Premium:

Gross Premium:

This policy will be rated by vehicle type. No mid-year paperwork is required for vehicle additions, changes, or deletions. After the completion of the policy term, a premium adjustment will be made for such changes. Potential vehicle suspensions are already contemplated in the above pricing, and no additional adjustments, either during the policy period, or at audit will be made for vehicle suspensions.

Consult Policy for Actual Terms and Conditions