

STATE OF NEBRASKA CONTRACT AWARD

State Purchasing Bureau
1526 K Street, Suite 130
Lincoln, Nebraska 68508

Telephone: (402) 471-6500
Fax: (402) 471-2089

CONTRACT NUMBER
13689 OC

PAGE 1 of 2	ORDER DATE 10/20/16
BUSINESS UNIT 9000	BUYER RENE BOTTS (AS)
VENDOR NUMBER: 501300	
VENDOR ADDRESS: CIMLINE INC 2601 NIAGARA LN N PLYMOUTH MN 55447-4721	

AN AWARD HAS BEEN MADE TO THE CONTRACTOR NAMED ABOVE FOR THE FURNISHING OF MATERIALS AND/OR SERVICES AS LISTED BELOW FOR THE PERIOD:

NOVEMBER 18, 2016 THROUGH NOVEMBER 17, 2017

NO ACTION ON THE PART OF THE CONTRACTOR NEEDS TO BE TAKEN AT THIS TIME. ORDERS FOR THE MATERIALS AND/OR SERVICES WILL BE MADE AS NEEDED BY THE VARIOUS AGENCIES OF THE STATE.

THIS CONTRACT IS NOT AN EXCLUSIVE CONTRACT TO FURNISH THE MATERIALS AND/OR SERVICES SHOWN BELOW, AND DOES NOT PRECLUDE THE PURCHASE OF SIMILAR MATERIALS AND/OR SERVICES FROM OTHER SOURCES.

THE STATE RESERVES THE RIGHT TO EXTEND THE PERIOD OF THIS CONTRACT BEYOND THE TERMINATION DATE WHEN MUTUALLY AGREEABLE TO THE CONTRACTOR AND THE STATE OF NEBRASKA.

Original/Bid Document 4487 OF

Contract to supply and deliver Heated Rubberized Asphalt Crack Sealing Machine, Min. 225 Gal. Capacity with Heated Hose to the State of Nebraska as per the attached specifications for the contract period November 18, 2016 through November 17, 2017. The contract may be renewed for one (1) additional one (1) year period when mutually agreeable to the vendor and the State of Nebraska.

Vendor Contact: Ben Thielbar
Phone: 800-328-3874
Fax: 866-557-1971
E-Mail: Bthielbar@cimline.com

This is the third renewal of the contract as amended (ka 10/17/16)

Line	Description	Estimated Quantity	Unit of Measure	Unit Price
1	HEATED RUBBERIZED ASPHALT CRACK SEALING MACHINE MIN 225	8.0000	EA	43,402.0000
	Make: CIMLINE			
	Model: MAGMA 230			
	Engine: ISUZU			
2	DEDUCT EQUIPMENT SHOP REPAIR MANUAL INDICATE PER UNIT COST	3.0000	EA	-30.0000
3	DEDUCT ENGINE SHOP REPAIR MANU INDICATE PER UNIT COST	3.0000	EA	-30.0000

Rene A. Botts 10/20/2016
BUYER KS 10/20/16
MATERIEL ADMINISTRATOR

STATE OF NEBRASKA CONTRACT AWARD

State Purchasing Bureau
1526 K Street, Suite 130
Lincoln, Nebraska 68508

Telephone: (402) 471-6500
Fax: (402) 471-2089

CONTRACT NUMBER
13689 OC

PAGE 2 of 2		ORDER DATE 10/20/16	
BUSINESS UNIT 9000		BUYER RENE BOTTS (AS)	
VENDOR NUMBER: 501300			

Line	Description	Estimated Quantity	Unit of Measure	Unit Price
4	DEDUCT EQUIPMENT PARTS MANUAL INDICATE PER UNIT COST	3.0000	EA	-15.0000
5	DEDUCT ENGINE PARTS MANUAL INDICATE PER UNIT COST	3.0000	EA	-15.0000
6	DEDUCT FOR NO TRAILER MOUNT AIR COMPRESSOR W/HOSE & REEL	7.0000	EA	-5,000.0000
7	110 VOLT, HEATING ELEMENTS FOR OVERNIGHT HEATING W/CONTROLS	8.0000	EA	800.0000
8	PRICE FOR ADDITIONAL HEATED HOSE W/SLEEVE	7.0000	EA	2,900.0000

[Faint, illegible text or stamp]

RAB
BUYER INITIALS

STATE OF NEBRASKA CONTRACT AMENDMENT

State Purchasing Bureau
1526 K Street, Suite 130
Lincoln, Nebraska 68508

Telephone: (402) 471-6500
Fax: (402) 471-2089

CONTRACT NUMBER
13689 OC

PAGE 1 of 2	ORDER DATE 09/02/16
BUSINESS UNIT 9000	BUYER RENE BOTTS (AS)
VENDOR NUMBER: 501300	
VENDOR ADDRESS: CIMLINE INC 2601 NIAGARA LN N PLYMOUTH MN 55447-4721	

THE CONTRACT PERIOD IS:

NOVEMBER 18, 2015 THROUGH NOVEMBER 17, 2016

THIS CONTRACT HAS BEEN AMENDED PER THE FOLLOWING INFORMATION:

NO ACTION ON THE PART OF THE CONTRACTOR NEEDS TO BE TAKEN AT THIS TIME. ORDERS FOR THE MATERIALS AND/OR SERVICES WILL BE MADE AS NEEDED BY THE VARIOUS AGENCIES OF THE STATE.

THIS CONTRACT IS NOT AN EXCLUSIVE CONTRACT TO FURNISH THE MATERIALS AND/OR SERVICES SHOWN BELOW, AND DOES NOT PRECLUDE THE PURCHASE OF SIMILAR MATERIALS AND/OR SERVICES FROM OTHER SOURCES.

THE STATE RESERVES THE RIGHT TO EXTEND THE PERIOD OF THIS CONTRACT BEYOND THE TERMINATION DATE WHEN MUTUALLY AGREEABLE TO THE CONTRACTOR AND THE STATE OF NEBRASKA.

Original/Bid Document 4487 OF

Contract to supply and deliver Heated Rubberized Asphalt Crack Sealing Machine, Min. 225 Gal. Capacity with Heated Hose to the State of Nebraska as per the attached specifications for the contract period November 18, 2015 through November 17, 2016. The contract may be renewed for two (2) additional one (1) year periods when mutually agreeable to the vendor and the State of Nebraska. The State reserves the right to extend the period of this contract beyond the termination date when mutually agreeable to the vendor and the State of Nebraska.

Vendor Contact: Ben Thielbar
Phone: 800-328-3874
Fax: 866-557-1971
E-Mail: Bthielbar@cimline.com

This is the second renewal of the contract as amended (jcd 11/05/15)

AMENDMENT ONE AS ATTACHED (ss 9/2/16)

Line	Description	Estimated Quantity	Unit of Measure	Unit Price
1	HEATED RUBBERIZED ASPHALT CRACK SEALING MACHINE MIN 225 Make: CIMLINE Model: MAGMA 230 Engine: ISUZU	8.0000	EA	43,402.0000
2	DEDUCT EQUIPMENT SHOP REPAIR MANUAL INDICATE PER UNIT COST	3.0000	EA	-30.0000

9/2/16
PK *Rene A. Botts* 9/2/2016
BUYER
9/2/16
MATERIEL ADMINISTRATOR

STATE OF NEBRASKA CONTRACT AMENDMENT

State Purchasing Bureau
1526 K Street, Suite 130
Lincoln, Nebraska 68508

Telephone: (402) 471-6500
Fax: (402) 471-2089

CONTRACT NUMBER
13689 OC

PAGE 2 of 2	ORDER DATE 09/02/16
BUSINESS UNIT 9000	BUYER RENE BOTTS (AS)
VENDOR NUMBER: 501300	

Line	Description	Estimated Quantity	Unit of Measure	Unit Price
3	DEDUCT ENGINE SHOP REPAIR MANU INDICATE PER UNIT COST	3.0000	EA	-30.0000
4	DEDUCT EQUIPMENT PARTS MANUAL INDICATE PER UNIT COST	3.0000	EA	-15.0000
5	DEDUCT ENGINE PARTS MANUAL INDICATE PER UNIT COST	3.0000	EA	-15.0000
6	DEDUCT FOR NO TRAILER MOUNT AIR COMPRESSOR W/HOSE & REEL	7.0000	EA	-5,000.0000
7	110 VOLT, HEATING ELEMENTS FOR OVERNIGHT HEATING W/CONTROLS	8.0000	EA	800.0000
8	PRICE FOR ADDITIONAL HEATED HOSE W/SLEEVE	7.0000	EA	2,900.0000

RAB
BUYER INITIALS

AMENDMENT ONE
13689 OC

Heated Rubberized Asphalt Crack Sealing Machine, Min. 225 Gal. Capacity with Heated Hose
for the State of Nebraska

Between
The State of Nebraska and Cimline Inc.

This Amendment (the "Amendment") is made by the State of Nebraska and Cimline Inc., parties to Contract 13689 OC (the "Contract"), and upon mutual agreement and other valuable consideration the parties agree to and hereby amend the contract as follows:

Effective upon signature:

Vendor Contact is replaced by:

Vendor Contact: Ben Thielbar
Phone: 800-328-3874
Fax: 866-557-1971
E-Mail: Bthielbar@cimline.com

This amendment and any attachments hereto will become part of the Contract. Except as set forth in this Amendment, the Contract is unaffected and shall continue in full force and effect in accordance with its terms. If there is conflict between this amendment and the Contract or any earlier amendment, the terms of this amendment will prevail.

IN WITNESS WHEREOF, the parties have executed this Amendment as of the date of execution by both parties below.

State of Nebraska

By: 

Name: Bo Botelho

Title: AS Material Administrator

Date: 8/2/16

Contractor: Cimline Inc.

By: 

Name: Ben Thielbar

Title: Director Sales

Date: 8/17/16

STATE OF NEBRASKA CONTRACT AWARD

State Purchasing Bureau
1526 K Street, Suite 130
Lincoln, Nebraska 68508

Telephone: (402) 471-6500
Fax: (402) 471-2089

CONTRACT NUMBER
13689 OC

PAGE 1 of 2	ORDER DATE 11/05/15
BUSINESS UNIT 9000	BUYER RENE BOTTS (AS)
VENDOR NUMBER: 501300	
VENDOR ADDRESS: CIMLINE INC 2601 NIAGARA LN N PLYMOUTH MN 55447-4721	

AN AWARD HAS BEEN MADE TO THE CONTRACTOR NAMED ABOVE FOR THE FURNISHING OF MATERIALS AND/OR SERVICES AS LISTED BELOW FOR THE PERIOD:

NOVEMBER 18, 2015 THROUGH NOVEMBER 17, 2016

NO ACTION ON THE PART OF THE CONTRACTOR NEEDS TO BE TAKEN AT THIS TIME. ORDERS FOR THE MATERIALS AND/OR SERVICES WILL BE MADE AS NEEDED BY THE VARIOUS AGENCIES OF THE STATE.

THIS CONTRACT IS NOT AN EXCLUSIVE CONTRACT TO FURNISH THE MATERIALS AND/OR SERVICES SHOWN BELOW, AND DOES NOT PRECLUDE THE PURCHASE OF SIMILAR MATERIALS AND/OR SERVICES FROM OTHER SOURCES.

THE STATE RESERVES THE RIGHT TO EXTEND THE PERIOD OF THIS CONTRACT BEYOND THE TERMINATION DATE WHEN MUTUALLY AGREEABLE TO THE CONTRACTOR AND THE STATE OF NEBRASKA.

Original/Bid Document 4487 OF

Contract to supply and deliver Heated Rubberized Asphalt Crack Sealing Machine, Min. 225 Gal. Capacity with Heated Hose to the State of Nebraska as per the attached specifications for the contract period November 18, 2015 through November 17, 2016. The contract may be renewed for two (2) additional one (1) year periods when mutually agreeable to the vendor and the State of Nebraska. The State reserves the right to extend the period of this contract beyond the termination date when mutually agreeable to the vendor and the State of Nebraska.

Vendor Contact: Steve Johnson
Phone: 800-328-3874
Fax: 866-557-1971
E-Mail: SJohnson@cimline.com

This is the second renewal of the contract as amended (cd 11/05/15)

Line	Description	Estimated Quantity	Unit of Measure	Unit Price
1	HEATED RUBBERIZED ASPHALT CRACK SEALING MACHINE MIN 225 Make: CIMLINE Model: MAGMA 230 Engine: ISUZU	3.0000	EA	43,402.0000
2	DEDUCT EQUIPMENT SHOP REPAIR MANUAL INDICATE PER UNIT COST	3.0000	EA	-30.0000
3	DEDUCT ENGINE SHOP REPAIR MANU INDICATE PER UNIT COST	3.0000	EA	-30.0000

Rene A Botts 11/5/2015 KS/S/15
BUYER
Mary Jo Botts
MATERIEL ADMINISTRATOR
01-615

STATE OF NEBRASKA CONTRACT AWARD

State Purchasing Bureau
1526 K Street, Suite 130
Lincoln, Nebraska 68508

Telephone: (402) 471-6500
Fax: (402) 471-2089

CONTRACT NUMBER
13689 OC

PAGE 2 of 2		ORDER DATE 11/05/15
BUSINESS UNIT 9000		BUYER RENE BOTTS (AS)
VENDOR NUMBER: 501300		

Line	Description	Estimated Quantity	Unit of Measure	Unit Price
4	DEDUCT EQUIPMENT PARTS MANUAL INDICATE PER UNIT COST	3.0000	EA	-15.0000
5	DEDUCT ENGINE PARTS MANUAL INDICATE PER UNIT COST	3.0000	EA	-15.0000
6	DEDUCT FOR NO TRAILER MOUNT AIR COMPRESSOR W/HOSE & REEL	3.0000	EA	-5,000.0000
7	110 VOLT, HEATING ELEMENTS FOR OVERNIGHT HEATING W/CONTROLS	3.0000	EA	800.0000
8	PRICE FOR ADDITIONAL HEATED HOSE W/SLEEVE	3.0000	EA	2,900.0000

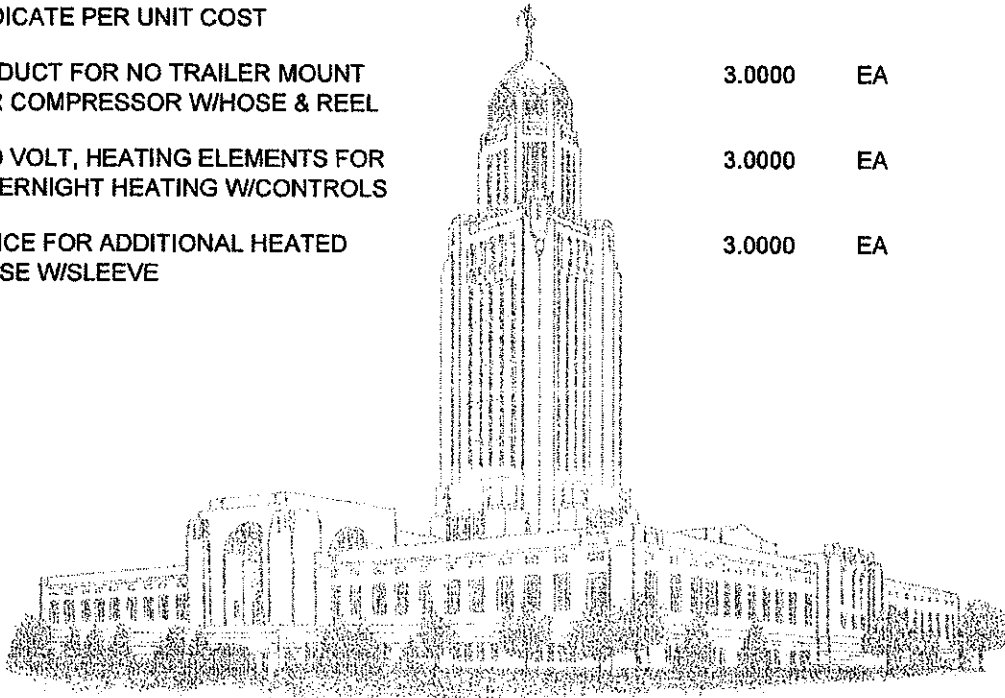

RAB
BUYER INITIALS

STATE OF NEBRASKA CONTRACT AWARD

State Purchasing Bureau
1526 K Street, Suite 130
Lincoln, Nebraska 68508

OR
P.O. Box 94847
Lincoln, Nebraska 68509-4847
Telephone: (402) 471-6500
Fax: (402) 471-2089

CONTRACT NUMBER
13689 OC

PAGE 1 of 4	ORDER DATE 10/21/14
BUSINESS UNIT 9000	BUYER TERESA FLEMING (AS)
VENDOR NUMBER: 501300	
VENDOR ADDRESS: CIMLINE INC 2601 NIAGARA LN N PLYMOUTH MINNESOTA 55447-4721	

AN AWARD HAS BEEN MADE TO THE VENDOR NAMED ABOVE FOR THE FURNISHING OF EQUIPMENT, MATERIAL, OR SUPPLIES AS LISTED BELOW FOR THE PERIOD:

NOVEMBER 18, 2014 THROUGH NOVEMBER 17, 2015

NO ACTION ON THE PART OF THE VENDOR NEEDS TO BE TAKEN AT THIS TIME. ORDERS FOR THE EQUIPMENT OR SUPPLIES WILL BE MADE AS NEEDED BY THE VARIOUS AGENCIES OF THE STATE.

THIS CONTRACT IS NOT AN EXCLUSIVE CONTRACT TO FURNISH THE EQUIPMENT OR SUPPLIES SHOWN BELOW, AND DOES NOT PRECLUDE THE PURCHASE OF SIMILAR ITEMS FROM OTHER SOURCES.

THE STATE RESERVES THE RIGHT TO EXTEND THE PERIOD OF THIS CONTRACT BEYOND THE TERMINATION DATE WHEN MUTUALLY AGREEABLE TO THE VENDOR AND THE STATE OF NEBRASKA.

Original/Bid Document 4487 OF

Contract to supply and deliver Heated Rubberized Asphalt Crack Sealing Machine, Min. 225 Gal. Capacity with Heated Hose to the State of Nebraska as per the attached specifications for the contract period November 18, 2014 through November 17, 2015. The contract may be renewed for three (3) additional one (1) year periods when mutually agreeable to the vendor and the State of Nebraska. The State reserves the right to extend the period of this contract beyond the termination date when mutually agreeable to the vendor and the State of Nebraska.

The State may request that payment be made electronically, instead of by state warrant. ACH/EFT Enrollment Form can be found at: <http://www.das.state.ne.us/accounting/forms/achenrol.pdf>

The Contractor is required and hereby agrees to use a federal immigration verification system to determine the work eligibility status of employees physically performing services within the State of Nebraska. A federal immigration verification system mean the electronic verification of the work authorization program authorized by the Illegal Immigration Reform and Responsibility Act of 1996, 8 U.S.C. 1324a, known as E-Verify Program, or an equivalent federal program designed by the United States Department of Homeland Security or other federal agency authorized to verify the work eligibility status of a newly hired employee.

The contractor, by signature to the Invitation to Bid, certifies that the contractor is not presently debarred, suspended, proposed for debarment, declared ineligible, or voluntarily excluded by any federal department or agency from participating in transactions (debarred). The contractor also agrees to include the above requirements in any and all subcontracts into which it enters. The contractor shall immediately notify the Department if, during the term of this contract, contractor becomes debarred. The Department may immediately terminate this contract by providing contractor written notice if contractor becomes debarred during the term of this contract.

If the Contractor is an individual or sole proprietorship, the following applies:

1. The Contractor must complete the United States Citizenship Attestation Form, available on the Department of Administrative Services website at: http://das.nebraska.gov/lb403/attestation_form.pdf
2. If the Contractor indicates on such attestation form that he or she is a qualified alien, the Contractor agrees to provide the US Citizenship and Immigration Services documentation require to verify the Contractor's lawful presence in the United States using the Systematic Alien Verification for Entitlements (SAVE) Program.

Teresa Fleming 10/22/14
BUYER 10-22-14
[Signature]
MATERIEL ADMINISTRATOR

STATE OF NEBRASKA CONTRACT AWARD

State Purchasing Bureau
 1526 K Street, Suite 130
 Lincoln, Nebraska 68508
 OR
 P.O. Box 94847
 Lincoln, Nebraska 68509-4847
 Telephone: (402) 471-6500
 Fax: (402) 471-2089

PAGE 2 of 4	ORDER DATE 10/21/14
BUSINESS UNIT 9000	BUYER TERESA FLEMING (AS)
VENDOR NUMBER: 501300	

**CONTRACT NUMBER
13689 OC**

3. The Contractor understands and agrees that lawful presence in the United States is required and the Contractor may be disqualified or the contract terminated if such lawful presence cannot be verified as required by Neb. Rev. Stat. §4-108.

The contract resulting from the Invitation to Bid shall incorporate the following documents:

1. Amendment to Contract Award with the most recent dated amendment having the highest priority;
2. Contract Award and any attached Addenda;
3. The signed Invitation to Bid form and the Contractor's bid response;
4. Amendments to ITB and any Questions and Answers; and
5. The original ITB document and any Addenda.

These documents constitute the entirety of the contract.

Unless otherwise specifically stated in a contract amendment, in case of any conflict between the incorporated documents, the documents shall govern in the following order of preference with number one (1) receiving preference over all other documents and with each lower numbered document having preference over any higher numbered document: 1) Amendment to Contract Award with the most recent dated amendment having the highest priority, 2) Contract Award and any attached Addenda, 3) the signed Invitation to Bid form and the Contractor's bid response, 4) Amendments to ITB and any Questions and Answers, 5) the original ITB document and any Addenda.

Any ambiguity in any provision of this contract which shall be discovered after its execution shall be resolved in accordance with the rules of contract interpretation as established in the State of Nebraska.

It is understood by the parties that in the State of Nebraska's opinion, any limitation on the contractor's liability is unconstitutional under the Nebraska State Constitution, Article XIII, Section III and that any limitation of liability shall not be binding on the State of Nebraska despite inclusion of such language in documents supplied by the contractor's bid response.

Vendor Contact: Steve Johnson
 Phone: 800-328-3874
 Fax: 866-557-1971
 E-Mail: SJohnson@cimline.com

This is the first renewal of the contract as amended (djo 10/21/14)

Line	Description	Estimated Quantity	Unit of Measure	Unit Price
1	HEATED RUBBERIZED ASPHALT CRACK SEALING MACHINE MIN 225 Make: CIMLINE Model: MAGMA 230 Engine: ISUZU	3.0000	EA	43,402.0000
2	DEDUCT EQUIPMENT SHOP REPAIR MANUAL INDICATE PER UNIT COST	3.0000	EA	-30.0000
3	DEDUCT ENGINE SHOP REPAIR MANU	3.0000	EA	-30.0000

 BUYER INITIALS

STATE OF NEBRASKA CONTRACT AWARD

State Purchasing Bureau
 1526 K Street, Suite 130
 Lincoln, Nebraska 68508
 OR

P.O. Box 94847
 Lincoln, Nebraska 68509-4847
 Telephone: (402) 471-6500
 Fax: (402) 471-2089

CONTRACT NUMBER
13689 OC

PAGE 3 of 4	ORDER DATE 10/21/14
BUSINESS UNIT 9000	BUYER TERESA FLEMING (AS)
VENDOR NUMBER: 501300	

Line	Description	Estimated Quantity	Unit of Measure	Unit Price
	INDICATE PER UNIT COST			
4	DEDUCT EQUIPMENT PARTS MANUAL INDICATE PER UNIT COST	3.0000	EA	-15.0000
5	DEDUCT ENGINE PARTS MANUAL INDICATE PER UNIT COST	3.0000	EA	-15.0000
6	DEDUCT FOR NO TRAILER MOUNT AIR COMPRESSOR W/HOSE & REEL	3.0000	EA	-5,000.0000
7	110 VOLT, HEATING ELEMENTS FOR OVERNIGHT HEATING W/CONTROLS	3.0000	EA	800.0000
8	PRICE FOR ADDITIONAL HEATED HOSE W/SLEEVE	3.0000	EA	2,900.0000

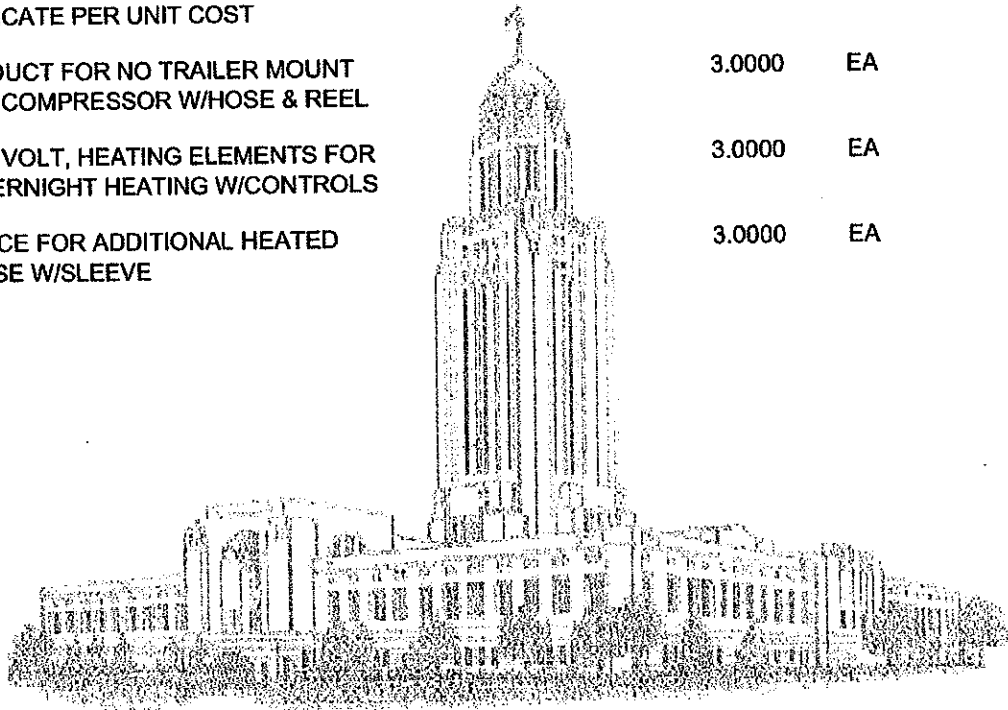

BUYER INITIALS

STANDARD CONDITIONS AND TERMS OF BID SOLICITATION AND OFFER Invitations to Bid and Contract Awards

It is the responsibility of the bidder to check the website for all information relevant to this solicitation to include addenda and/or amendments issued prior to the opening date. Website address: <http://www.das.state.ne.us/materiel/purchasing/purchasing.htm>

SCOPE- These standard conditions and terms of bid solicitation and acceptance apply in like force to this Inquiry and to any subsequent contract resulting therefrom.

PRICES- Prices quoted shall be net, including transportation and delivery charges fully prepaid by the bidder, F.O.B. destination named in the Invitation to Bid. No additional charges will be allowed for packing, packages or partial delivery costs. When an arithmetic error has been made in the extended total, the unit price will govern.

EXECUTION- Bids must be signed in ink by the bidder on the State of Nebraska's Invitation to Bid form. All bids must be typewritten or in ink on the State of Nebraska's Invitation to Bid form. Erasures and alterations must be initialed by the bidder in ink. No telephone or voice bids will be accepted. Failure to comply with these provisions may result in the rejection of the bid.

FACSIMILE DOCUMENTS- The State Purchasing Bureau will only accept facsimile responses to Invitations to Bid on bids under \$25,000 and up to ten (10) pages. However, two party sealed bids containing facsimile pages are acceptable. No direct facsimile solicitation responses will be accepted for a commodity contract.

VALID BID TIME- Bids shall be firm for a minimum of sixty (60) calendar days after the opening date, unless otherwise stipulated by either party in the Invitation to Bid.

DISCOUNTS- Prices quoted shall be inclusive of ALL trade discounts. Cash discount terms of less than thirty (30) days will not be considered as part of the bid. Cash discount periods will be computed from the date of receipt of a properly executed claim voucher or the date of completion of delivery of all items in a satisfactory condition, whichever is later.

PAYMENT- Payment will be made by the responsible agency in conjunction with the State of Nebraska Prompt Payment Act 81-2401 through 2406. The State may request that payment be made electronically instead of by state warrant.

COLLUSIVE BIDDING- The bidder guarantees that the prices quoted have been arrived at without collusion with other eligible bidders and without effort to preclude the State of Nebraska from obtaining the lowest possible competitive price.

LUMP SUM OR ALL OR NONE BIDS- The State reserves the right to purchase item-by-item, by groups or as a total when the State may benefit by so doing. Bidders may submit a bid on an "all or none" or "lump sum" basis but should also submit a bid on an item-by-item basis. The term "all or none" means a conditional bid which requires the purchase of all items on which bids are offered and bidder declines to accept award on individual items; a "lump sum" bid is one in which the bidder offers a lower price than the sum of the individual bids if all items are purchased but agrees to deliver individual items at the prices quoted.

SPECIFICATIONS- Any manufacturer's names, trade names, brand names, information and/or catalog numbers listed in a specification are for reference and not intended to limit competition, but will be used as the standard by which equivalent material offered will be judged. The State Purchasing Director will be the sole judge of equivalency. The bidder may offer any brand which meets or exceeds the specification. When a specific product is required, the Invitation to Bid will so state. Any item bid is to be the latest current model under standard production at the time of order. No used or refurbished equipment will be accepted, unless otherwise stated.

ALTERNATE/EQUIVALENT BIDS- Bidder may offer bids which are at variance from the express specifications of the Invitation to Bid. The State reserves the right to consider and accept such bids if, in the judgement of the State Purchasing Director, the bid will result in goods and/or services equivalent to or better than those which would be supplied in the original bid specifications. Bidders must indicate on the invitation to Bid the manufacturer's name, number and shall submit with their bid, sketches, descriptive literature and/or complete specifications. Reference to literature submitted with a previous bid will not satisfy this provision. Bids which do not comply with these requirements are subject to rejection. In the absence of any stated deviation or exception, the bid will be accepted as in strict compliance with all terms, conditions and specifications, and the bidder shall be held liable therefore.

SAMPLES- When requested, samples shall be furnished at the bidders expense prior to the opening of the bid, unless otherwise specified. Each sample must be labeled clearly and identify the bidders name, the Invitation to Bid number and the item number. Samples submitted must be representative of the commodities or equipment which would be delivered if awarded the bid. The State of Nebraska reserves the right to request samples even though this may not have been set forth in the Invitation to Bid. Samples not destroyed in testing will be returned at bidders expense, if requested, or will be donated to a public institution.

RECYCLING- Preference will be given to items which are manufactured or produced from recycled material or which can be readily reused or recycled after their normal use as per State Statute Section 81-15,159.

LATE BIDS- All bids will be time and date stamped upon receipt by the State Purchasing Bureau, and this shall be the official time and date of receipt. Bids received after the time of the bid opening will be considered late bids and will be returned to the bidder unopened. The State Purchasing Bureau is not responsible for late bids or lost requests due to mail service inadequacies, traffic or other similar reasons.

BID OPENING- Openings shall be public on the date and time specified on the invitation to Bid form. It is the bidder's responsibility to assure the bid is delivered at the designated date, time and place of the bid opening. Telephone bids are not acceptable. A bid may not be altered after opening of the bids.

NO BID- If not submitting a bid, respond by returning the invitation to Bid form explaining the reason in the space provided. Failure to respond to an invitation to Bid may be cause for the removal of the bidder's name from the mailing list. NOTE: To qualify as a respondent, bidder must submit a "NO BID" and it must be received no later than the stated bid opening date and time.

AWARD- All purchases, leases, or contracts which are based on competitive bids will be awarded to the lowest responsible bidder, determined according to the provisions of State Statute Section 81-161, R.R.S. 1943. The State reserves the right to reject any or all bids, wholly or in part and to waive any deviations or errors that are not material, do not invalidate the legitimacy of the bid and do not improve the bidders competitive position. All awards will be made in a manner deemed in the best interest of the State.

BID TABULATIONS- Tabulations will be furnished upon written request. A self-addressed, stamped envelope which must include the agency and solicitation number must be enclosed. Bid tabulations will not be provided by telephone or facsimile. Bid files may be examined during normal working hours by appointment. Bid tabulations are available on the website at: <http://www.das.state.ne.us/materiel/purchasing/bidtabs.htm>

PERFORMANCE AND DEFAULT- The State reserves the right to require a performance bond from the successful bidder, as provided by law, without expense to the State. Otherwise, in case of default of the contractor, the State may procure the articles from other sources and hold the contractor responsible for any excess cost occasioned thereby.

IN-STATE PREFERENCE- A resident bidder shall be allowed a preference against a nonresident from a state which gives or requires a preference to bidders from that state. The preference shall be equal to the preference given or required by the state of the nonresident bidders. Where the lowest responsible bid from a resident bidder is equal in all respects to one from a nonresident bidder from a state which has no preference law, the resident bidder shall be awarded the contract.

NONDISCRIMINATION- The Nebraska Fair Employment Practice Act prohibits contractors of the State of Nebraska, and their subcontractors, from discriminating against any employee or applicant for employment, to be employed in the performance of such contracts, with respect to hire, tenure, terms, conditions or privileges of employment because of race, color, religion, sex, disability, or national origin. (State Statute Sections 48-1101 through 48-1125) The bidder guarantees compliance with the Nebraska Fair Employment Practice Act, and breach of this provision shall be regarded as a material breach of contract. The contractor shall insert a similar provision in all subcontracts for services to be covered by any contract resulting from this Invitation to Bid.

TAXES- Purchases made by the State of Nebraska are exempt from the payment of Federal Excise Taxes, and exemption certificates will be furnished on request. State and local taxes are exempt by State Statute Section 77-2704 (l) (m) R.R.S. 1943 and must not be included in the bid prices. Exemption by statute precludes the furnishing of State exemption certificates.

DRUG POLICY - Bidder certifies that it maintains a drug free work place environment to ensure worker safety and workplace integrity. Contractor agrees to provide a copy of its drug free workplace policy at any time upon request by the State.

GRIEVANCE AND PROTEST- Grievance and protest procedure is available by contacting the buyer. Protest must be filed within ten (10) days of award.

NE ACCESS TECHNOLOGY STANDARDS- Vendor agrees to ensure compliance with Nebraska Access Technology Standards. See website at:

<http://www.nitc.state.ne.us/standards/accessibility/>

Revised: 02/2004

STATE OF NEBRASKA CONTRACT AWARD

State Purchasing Bureau
301 Centennial Mall South, 1st Floor
Lincoln, Nebraska 68508
OR
P.O. Box 94847
Lincoln, Nebraska 68509-4847
Telephone: (402) 471-2401
Fax: (402) 471-2089

PAGE 1 of 4	ORDER DATE 11/01/13
BUSINESS UNIT 27227020	BUYER TERESA FLEMING (AS)
VENDOR NUMBER: 501300	
VENDOR ADDRESS: CIMLINE INC 2601 NIAGARA LN N PLYMOUTH MINNESOTA 55447-4721	

CONTRACT NUMBER
13689 OC

AN AWARD HAS BEEN MADE TO THE VENDOR NAMED ABOVE FOR THE FURNISHING OF EQUIPMENT, MATERIAL, OR SUPPLIES AS LISTED BELOW FOR THE PERIOD:

NOVEMBER 18, 2013 THROUGH NOVEMBER 17, 2014

NO ACTION ON THE PART OF THE VENDOR NEEDS TO BE TAKEN AT THIS TIME. ORDERS FOR THE EQUIPMENT OR SUPPLIES WILL BE MADE AS NEEDED BY THE VARIOUS AGENCIES OF THE STATE.

THIS CONTRACT IS NOT AN EXCLUSIVE CONTRACT TO FURNISH THE EQUIPMENT OR SUPPLIES SHOWN BELOW, AND DOES NOT PRECLUDE THE PURCHASE OF SIMILAR ITEMS FROM OTHER SOURCES.

THE STATE RESERVES THE RIGHT TO EXTEND THE PERIOD OF THIS CONTRACT BEYOND THE TERMINATION DATE WHEN MUTUALLY AGREEABLE TO THE VENDOR AND THE STATE OF NEBRASKA.

Original/Bid Document 4487 OF

Contract to supply and deliver Heated Rubberized Asphalt Crack Sealing Machine, Min. 225 Gal. Capacity with Heated Hose to the State of Nebraska as per the attached specifications for a one (1) year period from date of award. The contract may be renewed for four (4) additional one (1) year periods when mutually agreeable to the vendor and the State of Nebraska. The State reserves the right to extend the period of this contract beyond the termination date when mutually agreeable to the vendor and the State of Nebraska.

The State may request that payment be made electronically instead of by state warrant. ACH/EFT Enrollment Form can be found at: <<http://www.das.state.ne.us/accounting/forms/achenrol.pdf>>

The Contractor is required and hereby agrees to use a federal immigration verification system to determine the work eligibility status of employees physically performing services within the State of Nebraska. A federal immigration verification system mean the electronic verification of the work authorization program authorized by the Illegal Immigration Reform and Responsibility Act of 1996, 8 U.S.C. 1324a, known as E-Verify Program, or an equivalent federal program designed by the United States Department of Homeland Security or other federal agency authorized to verify the work eligibility status of a newly hired employee.

The contractor, by signature to the Invitation to Bid, certifies that the contractor is not presently debarred, suspended, proposed for debarment, declared ineligible, or voluntarily excluded by any federal department or agency from participating in transactions (debarred). The contractor also agrees to include the above requirements in any and all subcontracts into which it enters. The contractor shall immediately notify the Department if, during the term of this contract, contractor becomes debarred. The Department may immediately terminate this contract by providing contractor written notice if contractor becomes debarred during the term of this contract.

If the Contractor is an individual or sole proprietorship, the following applies:

1. The Contractor must complete the United States Citizenship Attestation Form, available on the Department of Administrative Services website at: <http://das.nebraska.gov/lb403/attestation_form.pdf>
2. If the Contractor indicates on such attestation form that he or she is a qualified alien, the Contractor agrees to provide the US Citizenship and Immigration Services documentation require to verify the Contractor's lawful presence in the United States using the Systematic Alien Verification for Entitlements (SAVE) Program.

Teresa Fleming 11-15-13 ^{KS} 11-15-13
BUYER
MATERIEL ADMINISTRATOR

STATE OF NEBRASKA CONTRACT AWARD

State Purchasing Bureau
 301 Centennial Mall South, 1st Floor
 Lincoln, Nebraska 68508
 OR
 P.O. Box 94847
 Lincoln, Nebraska 68509-4847
 Telephone: (402) 471-2401
 Fax: (402) 471-2089

PAGE 2 of 4	ORDER DATE 11/01/13
BUSINESS UNIT 27227020	BUYER TERESA FLEMING (AS)
VENDOR NUMBER: 501300	

CONTRACT NUMBER
13689 OC

3. The Contractor understands and agrees that lawful presence in the United States is required and the Contractor may be disqualified or the contract terminated if such lawful presence cannot be verified as required by Neb. Rev. Stat. §4-108.

The contract resulting from the Invitation to Bid shall incorporate the following documents:

1. Amendment to Contract Award with the most recent dated amendment having the highest priority;
2. Contract Award and any attached Addenda;
3. The signed Invitation to Bid form and the Contractor's bid response;
4. Amendments to ITB and any Questions and Answers; and
5. The original ITB document and any Addenda.

These documents constitute the entirety of the contract.

Unless otherwise specifically stated in a contract amendment, in case of any conflict between the incorporated documents, the documents shall govern in the following order of preference with number one (1) receiving preference over all other documents and with each lower numbered document having preference over any higher numbered document: 1) Amendment to Contract Award with the most recent dated amendment having the highest priority, 2) Contract Award and any attached Addenda, 3) the signed Invitation to Bid form and the Contractor's bid response, 4) Amendments to ITB and any Questions and Answers, 5) the original ITB document and any Addenda.

Any ambiguity in any provision of this contract which shall be discovered after its execution shall be resolved in accordance with the rules of contract interpretation as established in the State of Nebraska.

Once Invitations to Bid are opened they become the property of the State of Nebraska and will not be returned.

It is understood by the parties that in the State of Nebraska's opinion, any limitation on the contractor's liability is unconstitutional under the Nebraska State Constitution, Article XIII, Section III and that any limitation of liability shall not be binding on the State of Nebraska despite inclusion of such language in documents supplied by the contractor's bid response.

Vendor Contact: Steve Johnson
 Phone: 800-328-3874
 Fax: 866-557-1971
 E-Mail: S.Johnson@cimline.com

(b1 11/01/13)

Line	Description	Estimated Quantity	Unit of Measure	Unit Price
1	HEATED RUBBERIZED ASPHALT CRACK SEALING MACHINE MIN 225	3.0000	EA	43,402.0000
	Make: CIMLINE			
	Model: MAGMA 230			
	Engine: ISUZU			
2	DEDUCT EQUIPMENT SHOP REPAIR MANUAL INDICATE PER UNIT COST	3.0000	EA	-30.0000

AS 11-15-13
 BUYER INITIALS

STATE OF NEBRASKA CONTRACT AWARD

State Purchasing Bureau
 301 Centennial Mall South, 1st Floor
 Lincoln, Nebraska 68508
 OR
 P.O. Box 94847
 Lincoln, Nebraska 68509-4847
 Telephone: (402) 471-2401
 Fax: (402) 471-2089

PAGE 3 of 4	ORDER DATE 11/01/13
BUSINESS UNIT 27227020	BUYER TERESA FLEMING (AS)
VENDOR NUMBER: 501300	

CONTRACT NUMBER
13689 OC

Line	Description	Estimated Quantity	Unit of Measure	Unit Price
3	DEDUCT ENGINE SHOP REPAIR MANU INDICATE PER UNIT COST	3.0000	EA	-30.0000
4	DEDUCT EQUIPMENT PARTS MANUAL INDICATE PER UNIT COST	3.0000	EA	-15.0000
5	DEDUCT ENGINE PARTS MANUAL INDICATE PER UNIT COST	3.0000	EA	-15.0000
6	DEDUCT FOR NO TRAILER MOUNT AIR COMPRESSOR W/HOSE & REEL	3.0000	EA	-5,000.0000
7	110 VOLT, HEATING ELEMENTS FOR OVERNIGHT HEATING W/CONTROLS	3.0000	EA	800.0000
8	PRICE FOR ADDITIONAL HEATED HOSE W/SLEEVE	3.0000	EA	2,900.0000

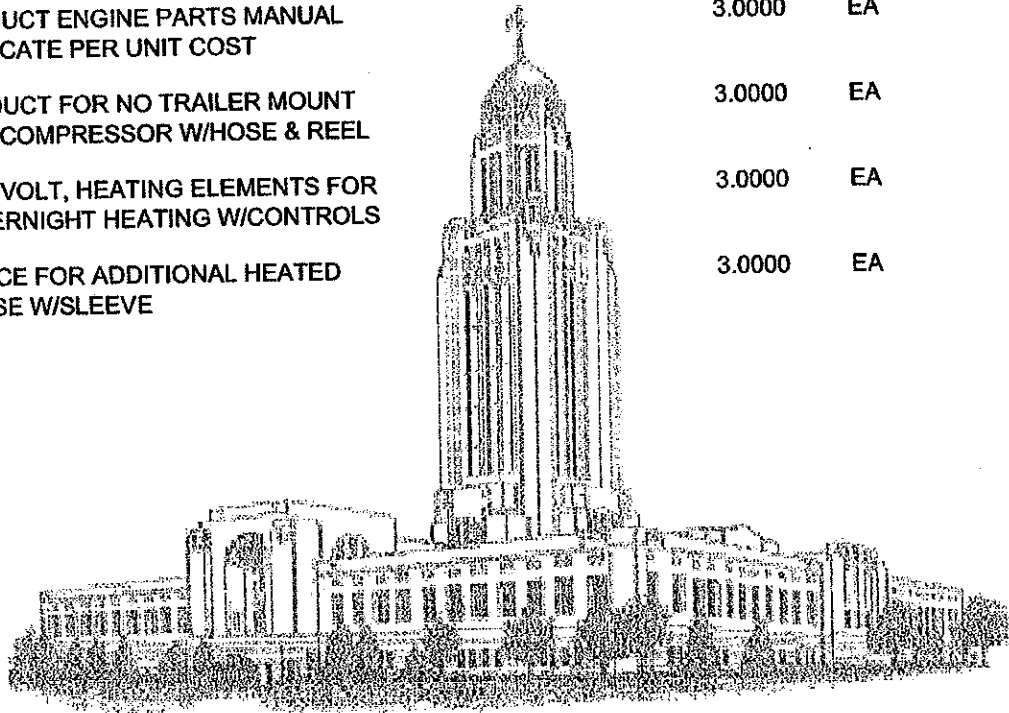

TF 11-15-13
 BUYER INITIALS

STANDARD CONDITIONS AND TERMS OF BID SOLICITATION AND OFFER Invitations to Bid and Contract Awards

It is the responsibility of the bidder to check the website for all information relevant to this solicitation to include addenda and/or amendments issued prior to the opening date. Website address: <http://www.das.state.ne.us/materiel/purchasing/purchasing.htm>

SCOPE- These standard conditions and terms of bid solicitation and acceptance apply in like force to this inquiry and to any subsequent contract resulting therefrom.

PRICES- Prices quoted shall be net, including transportation and delivery charges fully prepaid by the bidder, F.O.B. destination named in the Invitation to Bid. No additional charges will be allowed for packing, packages or partial delivery costs. When an arithmetic error has been made in the extended total, the unit price will govern.

EXECUTION- Bids must be signed in ink by the bidder on the State of Nebraska's Invitation to Bid form. All bids must be typewritten or in ink on the State of Nebraska's Invitation to Bid form. Erasures and alterations must be initialed by the bidder in ink. No telephone or voice bids will be accepted. Failure to comply with these provisions may result in the rejection of the bid.

FACSIMILE DOCUMENTS- The State Purchasing Bureau will only accept facsimile responses to Invitations to Bid on bids under \$25,000 and up to ten (10) pages. However, two party sealed bids containing facsimile pages are acceptable. No direct facsimile solicitation responses will be accepted for a commodity contract.

VALID BID TIME- Bids shall be firm for a minimum of sixty (60) calendar days after the opening date, unless otherwise stipulated by either party in the Invitation to Bid.

DISCOUNTS- Prices quoted shall be inclusive of ALL trade discounts. Cash discount terms of less than thirty (30) days will not be considered as part of the bid. Cash discount periods will be computed from the date of receipt of a properly executed claim voucher or the date of completion of delivery of all items in a satisfactory condition, whichever is later.

PAYMENT- Payment will be made by the responsible agency in conjunction with the State of Nebraska Prompt Payment Act 81-2401 through 2408. The State may request that payment be made electronically instead of by state warrant.

COLLUSIVE BIDDING- The bidder guarantees that the prices quoted have been arrived at without collusion with other eligible bidders and without effort to preclude the State of Nebraska from obtaining the lowest possible competitive price.

LUMP SUM OR ALL OR NONE BIDS- The State reserves the right to purchase item-by-item, by groups or as a total when the State may benefit by so doing. Bidders may submit a bid on an "all or none" or "lump sum" basis but should also submit a bid on an item-by-item basis. The term "all or none" means a conditional bid which requires the purchase of all items on which bids are offered and bidder declines to accept award on individual items; a "lump sum" bid is one in which the bidder offers a lower price than the sum of the individual bids if all items are purchased but agrees to deliver individual items at the prices quoted.

SPECIFICATIONS- Any manufacturer's names, trade names, brand names, information and/or catalog numbers listed in a specification are for reference and not intended to limit competition, but will be used as the standard by which equivalent material offered will be judged. The State Purchasing Director will be the sole judge of equivalency. The bidder may offer any brand which meets or exceeds the specification. When a specific product is required, the Invitation to Bid will so state. Any item bid is to be the latest current model under standard production at the time of order. No used or refurbished equipment will be accepted, unless otherwise stated.

ALTERNATE/EQUIVALENT BIDS- Bidder may offer bids which are at variance from the express specifications of the Invitation to Bid. The State reserves the right to consider and accept such bids if, in the judgement of the State Purchasing Director the bid will result in goods and/or services equivalent to or better than those which would be supplied in the original bid specifications. Bidders must indicate on the Invitation to Bid the manufacturer's name, number and shall submit with their bid, sketches, descriptive literature and/or complete specifications. Reference to literature submitted with a previous bid will not satisfy this provision. Bids which do not comply with these requirements are subject to rejection. In the absence of any stated deviation or exception, the bid will be accepted as in strict compliance with all terms, conditions and specifications, and the bidder shall be held liable therefore.

SAMPLES- When requested, samples shall be furnished at the bidders expense prior to the opening of the bid, unless otherwise specified. Each sample must be labeled clearly and identify the bidders name, the Invitation to Bid number and the item number. Samples submitted must be representative of the commodities or equipment which would be delivered if awarded the bid. The State of Nebraska reserves the right to request samples even though this may not have been set forth in the Invitation to Bid. Samples not destroyed in testing will be returned at bidders expense, if requested, or will be donated to a public institution.

RECYCLING- Preference will be given to items which are manufactured or produced from recycled material or which can be readily reused or recycled after their normal use as per State Statute Section 81-15,159.

LATE BIDS- All bids will be time and date stamped upon receipt by the State Purchasing Bureau, and this shall be the official time and date of receipt. Bids received after the time of the bid opening will be considered late bids and will be returned to the bidder unopened. The State Purchasing Bureau is not responsible for late bids or lost requests due to mail service inadequacies, traffic or other similar reasons.

BID OPENING- Openings shall be public on the date and time specified on the Invitation to Bid form. It is the bidder's responsibility to assure the bid is delivered at the designated date, time and place of the bid opening. Telephone bids are not acceptable. A bid may not be altered after opening of the bids.

NO BID- If not submitting a bid, respond by returning the Invitation to Bid form explaining the reason in the space provided. Failure to respond to an Invitation to Bid may be cause for the removal of the bidder's name from the mailing list. NOTE: To qualify as a respondent, bidder must submit a "NO BID" and it must be received no later than the stated bid opening date and time.

AWARD- All purchases, leases, or contracts which are based on competitive bids will be awarded to the lowest responsible bidder, determined according to the provisions of State Statute Section 81-161, R.R.S. 1943. The State reserves the right to reject any or all bids, wholly or in part and to waive any deviations or errors that are not material, do not invalidate the legitimacy of the bid, and do not improve the bidders competitive position. All awards will be made in a manner deemed in the best interest of the State.

BID TABULATIONS- Tabulations will be furnished upon written request. A self-addressed, stamped envelope which must include the agency and solicitation number must be enclosed. Bid tabulations will not be provided by telephone or facsimile. Bid files may be examined during normal working hours by appointment. Bid tabulations are available on the website at: <http://www.das.state.ne.us/materiel/purchasing/bidtabs.htm>

PERFORMANCE AND DEFAULT- The State reserves the right to require a performance bond from the successful bidder, as provided by law, without expense to the State. Otherwise, in case of default of the contractor, the State may procure the articles from other sources and hold the contractor responsible for any excess cost occasioned thereby.

IN-STATE PREFERENCE- A resident bidder shall be allowed a preference against a nonresident from a state which gives or requires a preference to bidders from that state. The preference shall be equal to the preference given or required by the state of the nonresident bidders. Where the lowest responsible bid from a resident bidder is equal in all respects to one from a nonresident bidder from a state which has no preference law, the resident bidder shall be awarded the contract.

NONDISCRIMINATION- The Nebraska Fair Employment Practice Act prohibits contractors of the State of Nebraska, and their subcontractors, from discriminating against any employee or applicant for employment, to be employed in the performance of such contracts, with respect to hire, tenure, terms, conditions or privileges of employment because of race, color, religion, sex, disability, or national origin. (State Statute Sections 48-1101 through 48-1125) The bidder guarantees compliance with the Nebraska Fair Employment Practice Act, and breach of this provision shall be regarded as a material breach of contract. The contractor shall insert a similar provision in all subcontracts for services to be covered by any contract resulting from this Invitation to Bid.

TAXES- Purchases made by the State of Nebraska are exempt from the payment of Federal Excise Taxes, and exemption certificates will be furnished on request. State and local taxes are exempt by State Statute Section 77-2704 (l) (m) R.R.S. 1943 and must not be included in the bid prices. Exemption by statute precludes the furnishing of State exemption certificates.

DRUG POLICY - Bidder certifies that it maintains a drug free work place environment to ensure worker safety and workplace integrity. Contractor agrees to provide a copy of its drug free workplace policy at any time upon request by the State.

GRIEVANCE AND PROTEST- Grievance and protest procedure is available by contacting the buyer. Protest must be filed within ten (10) days of award.

NE ACCESS TECHNOLOGY STANDARDS- Vendor agrees to ensure compliance with Nebraska Access Technology Standards. See website at:

<http://www.nitc.state.ne.us/standards/accessibility/>

Revised: 02/2004

State of Nebraska - INVITATION TO BID CONTRACT

Return to:
State Purchasing Bureau
301 Centennial Mall South, First Floor
Lincoln, Nebraska 68508
OR
P.O. Box 94847
Lincoln, NE 68509-4847
Telephone: 402-471-2401
Fax: 402-471-2089

Date	8/30/13	Page	1 of 4
Solicitation Number	4487 OF		
Opening Date and Time	09/17/13	2:00 pm	
Buyer	KRISTI KLING (AS)		

DESTINATION OF GOODS

DEPT OF ROADS
5001 S 14TH ST
PO BOX 94759
LINCOLN NE 68509-4759

Contract to supply and deliver Heated Rubberized Asphalt Crack Sealing Machine, Min. 225 Gal. Capacity with Heated Hose to the State of Nebraska as per the attached specifications for a one (1) year period from date of award. The contract may be renewed for four (4) additional one (1) year periods when mutually agreeable to the vendor and the State of Nebraska. The State reserves the right to extend the period of this contract beyond the termination date when mutually agreeable to the vendor and the State of Nebraska.

The State may request that payment be made electronically instead of by state warrant. ACH/EFT Enrollment Form can be found at: <<http://www.das.state.ne.us/accounting/forms/achenrol.pdf>>

The Contractor is required and hereby agrees to use a federal immigration verification system to determine the work eligibility status of employees physically performing services within the State of Nebraska. A federal immigration verification system mean the electronic verification of the work authorization program authorized by the Illegal Immigration Reform and Responsibility Act of 1996, 8 U.S.C. 1324a, known as E-Verify Program, or an equivalent federal program designed by the United States Department of Homeland Security or other federal agency authorized to verify the work eligibility status of a newly hired employee.

The contractor, by signature to the Invitation to Bid, certifies that the contractor is not presently debarred, suspended, proposed for debarment, declared ineligible, or voluntarily excluded by any federal department or agency from participating in transactions (debarred). The contractor also agrees to include the above requirements in any and all subcontracts into which it enters. The contractor shall immediately notify the Department if, during the term of this contract, contractor becomes debarred. The Department may immediately terminate this contract by providing contractor written notice if contractor becomes debarred during the term of this contract.

If the Contractor is an individual or sole proprietorship, the following applies:

1. The Contractor must complete the United States Citizenship Attestation Form, available on the Department of Administrative Services website at: <http://das.nebraska.gov/b403/attestation_form.pdf>
2. If the Contractor indicates on such attestation form that he or she is a qualified alien, the Contractor agrees to provide the US Citizenship and Immigration Services documentation require to verify the Contractor's lawful presence in the United States using the Systematic Alien Verification for Entitlements (SAVE) Program.
3. The Contractor understands and agrees that lawful presence in the United States is required and the Contractor may be disqualified or the contract terminated if such lawful presence cannot be verified as required by Neb. Rev. Stat. §4-108.

The contract resulting from the Invitation to Bid shall incorporate the following documents:

1. Amendment to Contract Award with the most recent dated amendment having the highest priority;

No Bid Respond: () Remove From Class-Item OR () Keep Active For Class-Item

BIDDER MUST COMPLETE THE FOLLOWING

DISCOUNT PAYMENT TERMS: 0 % 30 DAYS

By signing this invitation to Bid, the bidder agrees to the "Standard Conditions and Terms of Bid Solicitation and Offer" and is committed to provide a drug free work place environment. Vendor will furnish the items requested within 60 days after receipt of order. Failure to enter Delivery Date may cause quotation to be REJECTED.

Sign

Enter Contact Information Below

Here (Authorized Signature MANDATORY - MUST BE SIGNED IN INK)

VENDOR#

VENDOR:

Address:

Contact

Telephone

Facsimile

Email

CIMLINE INC.

2601 DIAGONA LN
PLYMOUTH, MN 55447

STEVE JOHNSON

800-328-3774

866-557-1971

SJOHNSON@CIMLINE.COM

State of Nebraska - INVITATION TO BID CONTRACT

Return to:
State Purchasing Bureau
301 Centennial Mall South, First Floor
Lincoln, Nebraska 68508
OR
P.O. Box 94847
Lincoln, NE 68509-4847
Telephone: 402-471-2401
Fax: 402-471-2089

Date	8/30/13	Page	2 of 4
Solicitation Number	4487 OF		
Opening Date and Time	09/17/13	2:00 pm	
Buyer	KRISTI KLING (AS)		

DESTINATION OF GOODS

DEPT OF ROADS
5001 S 14TH ST
PO BOX 94759
LINCOLN NE 68509-4759

2. Contract Award and any attached Addenda;
3. The signed Invitation to Bid form and the Contractor's bid response;
4. Amendments to ITB and any Questions and Answers; and
5. The original ITB document and any Addenda.

These documents constitute the entirety of the contract.

Unless otherwise specifically stated in a contract amendment, in case of any conflict between the incorporated documents, the documents shall govern in the following order of preference with number one (1) receiving preference over all other documents and with each lower numbered document having preference over any higher numbered document: 1) Amendment to Contract Award with the most recent dated amendment having the highest priority, 2) Contract Award and any attached Addenda, 3) the signed Invitation to Bid form and the Contractor's bid response, 4) Amendments to ITB and any Questions and Answers, 5) the original ITB document and any Addenda.

Any ambiguity in any provision of this contract which shall be discovered after its execution shall be resolved in accordance with the rules of contract interpretation as established in the State of Nebraska.

Once Invitations to Bid are opened they become the property of the State of Nebraska and will not be returned.

It is understood by the parties that in the State of Nebraska's opinion, any limitation on the contractor's liability is unconstitutional under the Nebraska State Constitution, Article XIII, Section III and that any limitation of liability shall not be binding on the State of Nebraska despite inclusion of such language in documents supplied by the contractor's bid response.

08/29/2013 ld

A response to this Solicitation is subject to, but not limited to, the included Standard Conditions and Terms. PLEASE READ CAREFULLY!

IT IS THE RESPONSIBILITY OF THE BIDDER TO REFER TO STATE PURCHASING BUREAU'S WEB SITE FOR ALL INFORMATION RELEVANT TO THIS SOLICITATION TO INCLUDE ADDENDA AND/OR AMENDMENTS THAT MAY BE ISSUED PRIOR TO THE OPENING DATE

<http://www.das.state.ne.us/materiel/purchasing/purchasing.html>

Bid Tabulations are available on the internet at <http://www.das.state.ne.us/materiel/purchasing/bidtabs.htm>

This form is part of the specification package and must be signed and returned, along with all documents, by the opening date and time specified.

Any questions regarding this solicitation must be directed to State Purchasing Bureau, to the attention of the buyer. It is preferred that questions be sent via e-mail to matpurch.dasmat@nebraska.gov. Questions may also be sent by facsimile to 402-471-2089. Refer to specification for additional information.

No facsimile or email solicitation responses will be accepted.

State of Nebraska - INVITATION TO BID CONTRACT

Return to:
State Purchasing Bureau
301 Centennial Mall South, First Floor
Lincoln, Nebraska 68508
OR
P.O. Box 94847
Lincoln, NE 68509-4847
Telephone: 402-471-2401
Fax: 402-471-2089

Date	8/30/13	Page	3 of 4
Solicitation Number	4487 OF		
Opening Date and Time	09/17/13	2:00 pm	
Buyer	KRISTI KLING (AS)		

DESTINATION OF GOODS

DEPT OF ROADS
5001 S 14TH ST
PO BOX 94759
LINCOLN NE 68509-4759

INVITATION

Line	Description	Quantity	Unit of Measure	Unit Price	Extended Price
1	HEATED RUBBERIZED ASPHALT CRACK SEALING MACHINE MIN 225 Make: <u>CIMLINE</u> Model: <u>MAGMA 230</u> Engine: <u>ISUZU</u>	3.0000	EA	\$ <u>43,402.⁰⁰</u>	\$ <u>130,206.⁰⁰</u>
2	DEDUCT EQUIPMENT SHOP REPAIR MANUAL INDICATE PER UNIT COST	3.0000	EA	<u>-30</u>	<u>-90</u>
3	DEDUCT ENGINE SHOP REPAIR MANU INDICATE PER UNIT COST	3.0000	EA	<u>-30</u>	<u>-90</u>
4	DEDUCT EQUIPMENT PARTS MANUAL INDICATE PER UNIT COST	3.0000	EA	<u>-15</u>	<u>-45</u>
5	DEDUCT ENGINE PARTS MANUAL INDICATE PER UNIT COST	3.0000	EA	<u>-15</u>	<u>-45</u>
6	DEDUCT FOR NO TRAILER MOUNT AIR COMPRESSOR W/HOSE & REEL	3.0000	EA	<u>-5000.⁰⁰</u>	<u>-15,000.⁰⁰</u>
7	110 VOLT, HEATING ELEMENTS FOR OVERNIGHT HEATING W/CONTROLS	3.0000	EA	<u>800</u>	<u>2400</u>
8	PRICE FOR ADDITIONAL HEATED HOSE W/SLEEVE	3.0000	EA	<u>2900</u>	<u>8700</u>

STANDARD CONDITIONS AND TERMS OF BID SOLICITATION AND OFFER Invitations to Bid and Contract Awards

It is the responsibility of the bidder to check the website for all information relevant to this solicitation to include addenda and/or amendments issued prior to the opening date. Website address: <http://www.das.state.ne.us/materiel/purchasing/purchasing.htm>

SCOPE- These standard conditions and terms of bid solicitation and acceptance apply in like force to this inquiry and to any subsequent contract resulting therefrom.

PRICES- Prices quoted shall be net, including transportation and delivery charges fully prepaid by the bidder, F.O.B. destination named in the Invitation to Bid. No additional charges will be allowed for packing, packages or partial delivery costs. When an arithmetic error has been made in the extended total, the unit price will govern.

EXECUTION- Bids must be signed in ink by the bidder on the State of Nebraska's Invitation to Bid form. All bids must be typewritten or in ink on the State of Nebraska's Invitation to Bid form. Erasures and alterations must be initialed by the bidder in ink. No telephone or voice bids will be accepted. Failure to comply with these provisions may result in the rejection of the bid.

FACSIMILE DOCUMENTS- The State Purchasing Bureau will only accept facsimile responses to Invitations to Bid on bids under \$25,000 and up to ten (10) pages. However, two party sealed bids containing facsimile pages are acceptable. No direct facsimile solicitation responses will be accepted for a commodity contract.

VALID BID TIME- Bids shall be firm for a minimum of sixty (60) calendar days after the opening date, unless otherwise stipulated by either party in the Invitation to Bid.

DISCOUNTS- Prices quoted shall be inclusive of ALL trade discounts. Cash discount terms of less than thirty (30) days will not be considered as part of the bid. Cash discount periods will be computed from the date of receipt of a properly executed claim voucher or the date of completion of delivery of all items in a satisfactory condition, whichever is later.

PAYMENT- Payment will be made by the responsible agency in conjunction with the State of Nebraska Prompt Payment Act 81-2401 through 2408. The State may request that payment be made electronically instead of by state warrant.

COLLUSIVE BIDDING- The bidder guarantees that the prices quoted have been arrived at without collusion with other eligible bidders and without effort to preclude the State of Nebraska from obtaining the lowest possible competitive price.

LUMP SUM OR ALL OR NONE BIDS- The State reserves the right to purchase item-by-item, by groups or as a total when the State may benefit by so doing. Bidders may submit a bid on an "all or none" or "lump sum" basis but should also submit a bid on an item-by-item basis. The term "all or none" means a conditional bid which requires the purchase of all items on which bids are offered and bidder declines to accept award on individual items; a "lump sum" bid is one in which the bidder offers a lower price than the sum of the individual bids if all items are purchased but agrees to deliver individual items at the prices quoted.

SPECIFICATIONS- Any manufacturer's names, trade names, brand names, information and/or catalog numbers listed in a specification are for reference and not intended to limit competition, but will be used as the standard by which equivalent material offered will be judged. The State Purchasing Director will be the sole judge of equivalency. The bidder may offer any brand which meets or exceeds the specification. When a specific product is required, the Invitation to Bid will so state. Any item bid is to be the latest current model under standard production at the time of order. No used or refurbished equipment will be accepted, unless otherwise stated.

ALTERNATE/EQUIVALENT BIDS- Bidder may offer bids which are at variance from the express specifications of the Invitation to Bid. The State reserves the right to consider and accept such bids if, in the judgement of the State Purchasing Director, the bid will result in goods and/or services equivalent to or better than those which would be supplied in the original bid specifications. Bidders must indicate on the Invitation to Bid the manufacturer's name, number and shall submit with their bid, sketches, descriptive literature and/or complete specifications. Reference to literature submitted with a previous bid will not satisfy this provision. Bids which do not comply with these requirements are subject to rejection. In the absence of any stated deviation or exception, the bid will be accepted as in strict compliance with all terms, conditions and specifications, and the bidder shall be held liable therefore.

SAMPLES- When requested, samples shall be furnished at the bidders expense prior to the opening of the bid, unless otherwise specified. Each sample must be labeled clearly and identify the bidders name, the Invitation to Bid number and the item number. Samples submitted must be representative of the commodities or equipment which would be delivered if awarded the bid. The State of Nebraska reserves the right to request samples even though this may not have been set forth in the Invitation to Bid. Samples not destroyed in testing will be returned at bidders expense, if requested, or will be donated to a public institution.

RECYCLING- Preference will be given to items which are manufactured or produced from recycled material or which can be readily reused or recycled after their normal use as per State Statute Section 81-15,159.

LATE BIDS- All bids will be time and date stamped upon receipt by the State Purchasing Bureau, and this shall be the official time and date of receipt. Bids received after the time of the bid opening will be considered late bids and will be returned to the bidder unopened. The State Purchasing Bureau is not responsible for late bids or lost requests due to mail service inadequacies, traffic or other similar reasons.

BID OPENING- Openings shall be public on the date and time specified on the Invitation to Bid form. It is the bidder's responsibility to assure the bid is delivered at the designated date, time and place of the bid opening. Telephone bids are not acceptable. A bid may not be altered after opening of the bids.

NO BID- If not submitting a bid, respond by returning the invitation to Bid form explaining the reason in the space provided. Failure to respond to an Invitation to Bid may be cause for the removal of the bidder's name from the mailing list. NOTE: To qualify as a respondent, bidder must submit a "NO BID" and it must be received no later than the stated bid opening date and time.

AWARD- All purchases, leases, or contracts which are based on competitive bids will be awarded to the lowest responsible bidder, determined according to the provisions of State Statute Section 81-161, R.R.S. 1943. The State reserves the right to reject any or all bids, wholly or in part and to waive any deviations or errors that are not material, do not invalidate the legitimacy of the bid and do not improve the bidder's competitive position. All awards will be made in a manner deemed in the best interest of the State.

BID TABULATIONS- Tabulations will be furnished upon written request. A self-addressed, stamped envelope which must include the agency and solicitation number must be enclosed. Bid tabulations will not be provided by telephone or facsimile. Bid files may be examined during normal working hours by appointment. Bid tabulations are available on the website at: <http://www.das.state.ne.us/materiel/purchasing/bidtabs.htm>

PERFORMANCE AND DEFAULT- The State reserves the right to require a performance bond from the successful bidder, as provided by law, without expense to the State. Otherwise, in case of default of the contractor, the State may procure the articles from other sources and hold the contractor responsible for any excess cost occasioned thereby.

IN-STATE PREFERENCE- A resident bidder shall be allowed a preference against a nonresident from a state which gives or requires a preference to bidders from that state. The preference shall be equal to the preference given or required by the state of the nonresident bidders. Where the lowest responsible bid from a resident bidder is equal in all respects to one from a nonresident bidder from a state which has no preference law, the resident bidder shall be awarded the contract.

NONDISCRIMINATION- The Nebraska Fair Employment Practice Act prohibits contractors of the State of Nebraska, and their subcontractors, from discriminating against any employee or applicant for employment, to be employed in the performance of such contracts, with respect to hire, tenure, terms, conditions or privileges of employment because of race, color, religion, sex, disability, or national origin. (State Statute Sections 48-1101 through 48-1125) The bidder guarantees compliance with the Nebraska Fair Employment Practice Act, and breach of this provision shall be regarded as a material breach of contract. The contractor shall insert a similar provision in all subcontracts for services to be covered by any contract resulting from this invitation to Bid.

TAXES- Purchases made by the State of Nebraska are exempt from the payment of Federal Excise Taxes, and exemption certificates will be furnished on request. State and local taxes are exempt by State Statute Section 77-2704 (l) (m) R.R.S. 1943 and must not be included in the bid prices. Exemption by statute precludes the furnishing of State exemption certificates.

DRUG POLICY - Bidder certifies that it maintains a drug free work place environment to ensure worker safety and workplace integrity. Contractor agrees to provide a copy of its drug free workplace policy at any time upon request by the State.

GRIEVANCE AND PROTEST- Grievance and protest procedure is available by contacting the buyer. Protest must be filed within ten (10) days of award.

NE ACCESS TECHNOLOGY STANDARDS- Vendor agrees to ensure compliance with Nebraska Access Technology Standards. See website at: <http://www.nitc.state.ne.us/standards/accessibility/>

**STATE OF NEBRASKA
STATE PURCHASING BUREAU**

SCHEDULE OF EVENTS

The State expects to adhere to the tentative procurement schedule shown below. It should be noted, however, that some dates are approximate and subject to change.

ACTIVITY		DATE/TIME
1	Release Invitation to Bid	August 30, 2013
2	Last Day to Submit Written Questions	September 6, 2013
3	State Responds to Written Questions Through an Addendum to be posted to the internet at: http://www.das.state.ne.us/materiel/purchasing/rfp.htm	September 10, 2013
4	Bid Opening Location: Nebraska State Office Building State Purchasing Bureau 301 Centennial Mall South, Mall Level Lincoln, NE 68508	September 17, 2013 2:00 p.m. Central Time

WRITTEN QUESTIONS AND ANSWERS

Any explanation desired by a bidder regarding the meaning or interpretation of any Invitation to Bid provision must be submitted in writing to the State Purchasing Bureau and clearly marked 4487 OF; Heated Rubberized Asphalt Crack Sealing Machine, Minimum 225 Gallon Capacity with Heated Hose. It is preferred that questions be sent via e-mail to matpurch.dasmat@nebraska.gov. Questions may also be sent by facsimile to 402-471-2089, but must include a cover sheet clearly indicating that the transmission is to the attention of Kristi Kling, showing the total number of pages transmitted, and clearly marked 4487 OF; Heated Rubberized Asphalt Crack Sealing Machine, Minimum 225 Gallon Capacity with Heated Hose".

Written answers will be provided through an addendum to be posted on the internet at <http://www.das.state.ne.us/materiel/purchasing/rfp.htm> on or before the date shown in the Schedule of Events.

**STATE OF NEBRASKA
DEPARTMENT OF ROADS**

**Terms and Conditions for
Heated Rubberized Asphalt Crack Sealing Machine,
Minimum 225 Gallon Capacity with Heated Hose**

W16-13

SCOPE

THE **Heated Rubberized Asphalt Crack Sealing Machine, Minimum 225 Gallon Capacity with Heated Hose** SHALL BE THE LATEST CURRENT MODEL OF PROVEN PERFORMANCE AND UNDER STANDARD PRODUCTION BY THE MANUFACTURER AND IS TO BE OF STANDARD DESIGN, COMPLETE AS REGULARLY ADVERTISED AND MARKETING INCLUDING ALL SPECIFIED ACCESSORIES, TOOLS AND SPECIAL FEATURES. All necessary parts for satisfactory operation of the equipment shall be furnished whether or not they may be specifically mentioned below. Complete detailed specifications and advertising data sheets with cuts or photographs should be attached to the invitation to bid on the IDENTICAL equipment proposed. ANY INFORMATION NECESSARY TO SHOW COMPLIANCE WITH THESE SPECIFICATIONS, IN ADDITION TO INFORMATION GIVEN ON ADVERTISING DATA SHEETS, SHOULD BE SUPPLIED IN WRITING AND ATTACHED TO THE BID DOCUMENT. The **Heated Rubberized Asphalt Crack Sealing Machine, Minimum 225 Gallon Capacity with Heated Hose** must meet or exceed the following requirements.

NON-COMPLIANCE STATEMENT

Read this specification carefully. Any and all exceptions to this specification must be written on or attached to invitation to bid. Non-compliance can void your bid. It is the responsibility of the Bidders to obtain information and clarifications as provided on the Schedule of Events. The State of Nebraska is not responsible for any erroneous or incomplete understandings or wrongful interpretations of this Invitation to Bid by any Bidder.

PERIOD OF CONTRACT

Contract to supply and deliver **Heated Rubberized Asphalt Crack Sealing Machine, Minimum 225 Gallon Capacity with Heated Hose** to various locations upon request per the attached specifications, terms and conditions for a one (1) year period beginning from date of contract award with the option to renew for four (4) additional one (1) year periods when mutually agreeable to the vendor and the State of Nebraska. The State reserves the right to extend the period of this contract beyond the termination date when mutually agreeable to the vendor and the State of Nebraska.

AMENDMENT

This Contract may be amended at any time in writing upon the agreement of both parties.

RIGHTS

The State of Nebraska reserves the right to waive technicalities and reject any or all bids. The State of Nebraska will be the sole judge of equivalence and any decision will be final.

Contract supplier or suppliers may honor pricing and extend the contract to political sub-divisions, cities and counties. Terms and conditions of the contract must be met by political sub-divisions, cities and counties. Under no circumstances shall the State of Nebraska be contractually obligated or liable for any purchases by political sub-divisions, cities or counties.

TERMINATION

The Contract may be terminated at any time upon the mutual consent of the parties, or by either party, with or without cause, upon thirty (30) days written notice to the other party.

BREACH OF CONTRACT

If the Contractor breaches this Contract, the State of Nebraska may, at its discretion, terminate the contract immediately upon written notice to the Contractor. The State of Nebraska shall pay the Contractor only for such performance as has been properly completed and is of use to the State of Nebraska. The State of Nebraska may, at its discretion, contract for

provision of the goods or services required to complete this Contract and hold the Contractor liable for all expenses incurred in such additional contract over and above the total cost of performance. This provision shall not preclude the pursuit of other remedies for breach of contract as allowed by law.

ANNUAL USAGE

This is an open-ended contract between the vendor and the State to furnish an undetermined quantity of **Heated Rubberized Asphalt Crack Sealing Machine, Minimum 105 Gallon Capacity with Heated Hose** in a given period of time. Quantities stated are estimates only and shall not be construed to either be a minimum or a maximum.

ORDERS/INVOICES

The ordering entity will submit their orders directly to the contractor on an as needed basis, using their own standard purchase order form. Orders may be placed by phone, fax, mail, or Internet (if available). All orders must be assigned a purchase order number, and the purchase order must be referenced on the invoice. All invoices are to be sent to the address shown on the purchase order.

DELIVERY

Between 9:00 AM and 3:00 PM, daily, except Saturdays, Sundays and holidays. Delivery desired prior to 60 days after receipt of purchase order; deliveries quoted beyond 60 days are an award consideration. Vendor must notify Fleet Management minimum of 24 hours prior to delivery on workday basis at (402) 479-4319 or 479-4323. Department of Roads' equipment will be delivered to 5001 South 14th Street, Lincoln, Nebraska.

ACCEPTABLE BRANDS

Cimline

Crafco

Other brands must be demonstrated near Lincoln, Nebraska, have adequate references provided, have adequate service facilities in Nebraska, be field proven and be approved in writing by Fleet Management of the Department of Roads five (5) days prior to bid opening.

**STATE OF NEBRASKA
DEPARTMENT OF ROADS**

**Specification for
Heated Rubberized Asphalt Crack Sealing Machine,
Minimum 225 Gallon Capacity with Heated Hose**

Bidder Instructions:

Bidder must respond to each of the following statements. Specifications listed are minimum conditions that must be met in order for a bidder to qualify for the award.

MEETS SPECIFICATIONS – Please indicate – (If response is No & Provide Alternative, explain on Notes/Alternative line)

YES	NO	NO & PROVIDE ALTERNATIVE
<input checked="" type="checkbox"/>	<input type="checkbox"/>	<input type="checkbox"/>
<input checked="" type="checkbox"/>	<input type="checkbox"/>	<input type="checkbox"/>

QUALITY:

1. Products must meet specifications and be of first quality, free of damage and/or defect and must be under standard production by the manufacturer and be of standard design, complete as regularly advertised and marketed and be of proven performance. A guarantee of satisfactory performance of the product, performance of the supplier, and the supplier meeting delivery dates are all considered to be integral parts of the contract resulting from this bid invitation.

2. Failure to conform to the Specifications and Terms and Conditions constitutes a breach of this contract, and the State may reject the entire order or any part thereof and may recover the expenses and/or damages of such breach. The State of Nebraska may, also at its discretion, terminate the contract immediately upon written notice to the contractor and/or pay the contractor only for such performance as has been properly completed and is of use to the State and contract for provision of the services required to complete this contract and hold the contractor liable for all expenses incurred in such additional contract over and above the total cost of performance. This provision shall not preclude the pursuit of other remedies for breach of contract as allowable by law.

Notes/Alternative: _____

YES	NO	NO & PROVIDE ALTERNATIVE
<input checked="" type="checkbox"/>	<input type="checkbox"/>	<input type="checkbox"/>

PRICE:

Prices quoted shall be unit price (each) and shall be firm for 90 days from date of an award and are to be net; including transportation and delivery charges fully prepaid by the bidder F.O.B. destination as specified on each Purchase Order or under separate cover with each order. No additional charges will be allowed for packing, handling, or partial delivery costs. Any request for an increase must be submitted in writing to the State Purchasing Bureau a minimum of 30 days prior to proposed effective date of increase, and must show cause and be accompanied by supporting documentation (such as notification letter from the manufacturer). Supporting documentation must clearly establish the increase is to all customers, not to the State of Nebraska alone. Further documentation may be required by the State, to authenticate the increase (manufacturer invoices). Failure to supply any requested supporting documentation may be grounds to cancel the contract. The State further reserves the right to reject any proposed price increase(s), cancel the contract and re-bid if determined to be in the best interest of the State. No price increases are to be billed to any State Agencies without *prior* written approval by the State Purchasing Bureau. The State will be given full

proportionate benefit of any decrease for the term of the contract.

Notes/Alternative: _____

YES	NO	NO & PROVIDE ALTERNATIVE	
<input checked="" type="checkbox"/>	_____	_____	1. MELTING VAT SYSTEM
<input checked="" type="checkbox"/>	_____	_____	A. Mixing/holding tank shall be of double boiler construction
<input checked="" type="checkbox"/>	_____	_____	B. Minimum 225 gallon capacity material tank
<input checked="" type="checkbox"/>	_____	_____	C. Minimum 10 gauge steel vat
<input checked="" type="checkbox"/>	_____	_____	D. 50 to 550 degrees Fahrenheit dial stem or digital thermometer
<input checked="" type="checkbox"/>	_____	_____	E. Full length agitator with dual blades or auger system to break up and blend material; surrounded by minimum 12 gauge steel oil jacket
<input checked="" type="checkbox"/>	_____	_____	F. Hot oil expansion tank required if available from manufacturer
<input checked="" type="checkbox"/>	_____	_____	G. The heating jacket will have a 50-550 degrees Fahrenheit dial stem or digital thermometer
<input checked="" type="checkbox"/>	_____	_____	1. Oil filler cap and dipstick
<input checked="" type="checkbox"/>	_____	_____	2. Insulated by minimum 2" of fiberglass or 1" of ceramic
<input checked="" type="checkbox"/>	_____	_____	3. Insulated encased in a minimum 22 gauge shell
<input checked="" type="checkbox"/>	_____	_____	H. Anti-splash or safety loading chute with minimum 250 square inch opening required

Notes/Alternative: _____

YES	NO	NO & PROVIDE ALTERNATIVE	
<input checked="" type="checkbox"/>	_____	_____	2. HEATING SYSTEM
<input checked="" type="checkbox"/>	_____	_____	A. Diesel fueled by minimum 275,000 BTU burner
<input checked="" type="checkbox"/>	_____	_____	B. Capable of melting rubberized asphalt at the minimum rate of about 200 gallons per hour or 1,700 pounds per hour after initial heat-up
<input checked="" type="checkbox"/>	_____	_____	C. Burner chamber shall have minimum 5,000 square inch heat transfer area that exhausts to vertical stack with rain cover(s), and have heat transfer efficiency rating of at least 94%
<input checked="" type="checkbox"/>	_____	_____	D. Burners will be equipped with a fully automatic thermostatic oil temperature control system with a pressure regulator and gauge
<input checked="" type="checkbox"/>	_____	_____	E. Outfire shutoff valve and a built-in, self-contained electric ignition system
<input checked="" type="checkbox"/>	_____	_____	F. All unit controls will be in a weather-tight lockable box

Notes/Alternative: _____

YES	NO	NO & PROVIDE ALTERNATIVE	
<input checked="" type="checkbox"/>	_____	_____	3. SEALANT AND APPLICATOR SYSTEM
<input checked="" type="checkbox"/>	_____	_____	A. Sealant will be circulated and delivered through a hydraulically driven minimum 12 GPM pump OR a 6 GPM pump if "pump on demand" system is used.
<input checked="" type="checkbox"/>	_____	_____	1. Pump to be external of material tank and within heated enclosure
<input checked="" type="checkbox"/>	_____	_____	B. Unit is to be equipped with electrically heated hose
<input checked="" type="checkbox"/>	_____	_____	1. Unit shall have a heated enclosure to provide storage and provision for using a non-heated hose as various conditions and operations occur
<input checked="" type="checkbox"/>	_____	_____	C. Sealant delivery hose shall allow for a 14' working radius from the rear center of the machine
<input checked="" type="checkbox"/>	_____	_____	1. Continuously heated by 110 volt or 12 volt electrically heated hose and wand
<input checked="" type="checkbox"/>	_____	_____	2. Trigger control wand preferred. If <u>not</u> furnishing trigger control wand, please state what you are furnishing:

TRIGGER CONTROL WAND

W16-13

<input checked="" type="checkbox"/>		
<input checked="" type="checkbox"/>		
<input checked="" type="checkbox"/>		
<input checked="" type="checkbox"/>		
<input checked="" type="checkbox"/>		

- 3. Rated for minimum 500 degrees Fahrenheit temperature
- 4. Steel braided with Teflon lining or equivalent
- 5. Protected by separate hose sheath
- C. Pressure-regulating device will be provided to regulate pressure from applicator nozzle if not "pump on demand" system
- D. Swing arm boom for support of application hose is required

Notes/Alternative: _____

YES	NO	NO & PROVIDE ALTERNATIVE
<input checked="" type="checkbox"/>		
<input checked="" type="checkbox"/>		
<input checked="" type="checkbox"/>		
<input checked="" type="checkbox"/>		
<input checked="" type="checkbox"/>		
<input checked="" type="checkbox"/>		
<input checked="" type="checkbox"/>		
<input checked="" type="checkbox"/>		

4. ENGINE AND DRIVE

- A. Diesel, minimum of 25 horsepower
- B. 12 volt electric start
- C. Battery, alternator, and rainproof muffler(s)
- D. Power transmitted through hydraulic pumps and motors in such a fashion that pump and agitator can be operated together or separately in either forward or reverse rotation
- E. Hourmeter connected to engine is required
- F. A minimum 25 gallon diesel fuel tank for engines and burners required
- G. Liquid cooled engines will be protected to minimum 34 degrees below zero Fahrenheit with ethylene glycol solution
- H. Engine cover required

Notes/Alternative: _____

YES	NO	NO & PROVIDE ALTERNATIVE
<input checked="" type="checkbox"/>		
<input checked="" type="checkbox"/>		
<input checked="" type="checkbox"/>		
<input checked="" type="checkbox"/>		
<input checked="" type="checkbox"/>		
<input checked="" type="checkbox"/>		
<input checked="" type="checkbox"/>		
<input checked="" type="checkbox"/>		
<input checked="" type="checkbox"/>		
<input checked="" type="checkbox"/>		
<input checked="" type="checkbox"/>		
<input checked="" type="checkbox"/>		
<input checked="" type="checkbox"/>		
<input checked="" type="checkbox"/>		
<input checked="" type="checkbox"/>		
<input checked="" type="checkbox"/>		
<input checked="" type="checkbox"/>		
<input checked="" type="checkbox"/>		
<input checked="" type="checkbox"/>		
<input checked="" type="checkbox"/>		

5. TRAILER UNIT

- A. Single or dual axle minimum 6,800 pound rating, adequate suspension to meet requirement of fully loaded machine
- B. Steel disc wheels desired
- C. Electric brake system required
 - 1. 12" x 2" brakes on both axles with safety breakaway
 - 2. Each axle shall be wired to an individual circuit breaker. Circuit breakers may be dealer installed.
 - 3. A 12 volt breakaway safety switch with necessary electrical wiring shall be included at front of tongue
 - 4. Brake system shall be DOT compliant for the State of Nebraska
- D. Tires shall be of adequate size and load range to meet GVWR of trailer. State size and load range of tire to be provided: 15" C
- E. Tires should be Bridgestone, Goodyear, BF Goodrich, Michelin, Firestone, General, Titan, or Uniroyal, and carry said brand name. If manufacturer cannot furnish above brand name tires, please specify what brand you will be furnishing: TOW MAXX, TOW MASTER OR EQUIVALENT
- F. Fenders and license plate bracket required
- G. Running lights conforming to federal requirements
- H. 3" towing eye with height adjustments approximately 20-30" from grade in about 2" increments
- I. Adjustable tongue jack with caster
- J. Frame fabricated to adequately support the machine
- K. Safety chains with hooks and retaining ability from trailer to pulling unit are required
- L. Electrical connector of 7-way ATA type from trailer to towing vehicle; wired

_____	_____	_____
_____	_____	_____
_____	_____	_____

- per instructions with plug (see attached drawing)
- M. Trailer unit to have mounted rotary vane or rotary screw type air compressor
1. Compressor to have minimum 50 CFM and 100psi rating
 2. 50' hose on an integrated retracting hose reel shall be supplied. Hose reel may be dealer installed in suitable and convenient location.

Notes/Alternative: _____

YES	NO	NO & PROVIDE ALTERNATIVE
<input checked="" type="checkbox"/>	_____	_____

6. NOISE LEVEL

- A. Bidder shall supply with proposal the following decibel level per SAE Standards:
- Under full load in operator's position with doors and windows open
LESS THAN 75
- Under full load in bystander's position at 7.5 meters from rear of unit
LESS THAN 90

Notes/Alternative: _____

YES	NO	NO & PROVIDE ALTERNATIVE
<input checked="" type="checkbox"/>	_____	_____
<input checked="" type="checkbox"/>	_____	_____
<input checked="" type="checkbox"/>	_____	_____
<input checked="" type="checkbox"/>	_____	_____
<input checked="" type="checkbox"/>	_____	_____
<input checked="" type="checkbox"/>	_____	_____

7. MANUALS

- A. Operator's manual must accompany each unit delivered
- B. Equipment shop repair manual is required with each unit delivered
- C. Equipment parts manual is required with each unit delivered
- D. Engine shop repair manual is required with each unit delivered
- E. Engine parts manual is required with each unit delivered
- F. All manual(s) must be furnished prior to payment and delivered to Fleet Management, Equipment Data Coordinator. Failure to deliver all manuals that are ordered may result in non-payment of ten percent (10%) of purchase order until all manuals are delivered.

Notes/Alternative: _____

YES	NO	NO & PROVIDE ALTERNATIVE
<input checked="" type="checkbox"/>	_____	_____
<input checked="" type="checkbox"/>	_____	_____
<input checked="" type="checkbox"/>	_____	_____
<input checked="" type="checkbox"/>	_____	_____

8. MISCELLANEOUS

- A. Bidder will submit with their proposal a list of any special tools they will furnish with each machine
- B. Dealer's decals, stickers or other signs shall not be affixed to units; manufacturer's nameplates, stampings and other similar signs are acceptable
- D. Dealer pre-delivery service required
- E. Color – manufacturer's standard color, but black is preferred. Unit will be primed prior to final coat.

Notes/Alternative: _____

YES	NO	NO & PROVIDE ALTERNATIVE
<input checked="" type="checkbox"/>	_____	_____
<input checked="" type="checkbox"/>	_____	_____

9. WARRANTY

- A. Manufacturer's usual warranty shall apply and shall be in effect for at least one (1) year from the date the equipment is placed in service by the Nebraska Department of Roads (NDOR)
 1. This warranty shall cover all inspected parts determined to have been defective in material or workmanship.

W16-13

<input checked="" type="checkbox"/>	_____	_____
<input checked="" type="checkbox"/>	_____	_____
<input checked="" type="checkbox"/>	_____	_____

- B. Vendor shall be responsible for all repairs, to include parts and labor, during the 12 month usual warranty period
- C. All transportation costs to and from the nearest authorized repair facility will be the responsibility of the NDOR
- D. Authorized repair facility to be located in Nebraska. Please list authorized repair facilities:

_____ ROSE EQUIPMENT

Notes/Alternative: _____

YES	NO	NO & PROVIDE ALTERNATIVE
<input checked="" type="checkbox"/>	_____	_____
<input checked="" type="checkbox"/>	_____	_____
<input checked="" type="checkbox"/>	_____	_____

10. SPECIFICATION FORM

- A. Successful bidder will be required to complete form to the fullest extent possible for each unit and must accompany each unit when delivered.
- B. Forms will be supplied by the Department of Roads to successful bidder after contract is awarded.
- C. If vendor does not properly complete form for each unit, a sum of \$250.00 per unit will be deducted from purchase order amount.

Notes/Alternative: _____

YES	NO	NO & PROVIDE ALTERNATIVE
<input checked="" type="checkbox"/>	_____	_____

11. TRAINING

- A. Successful bidder must furnish a factory-trained representative in operation maintenance for eight (8) hours of instruction for each unit at its location within the State of Nebraska. Fleet Management will contact vendor regarding schedule.

Notes/Alternative: _____

YES	NO	NO & PROVIDE ALTERNATIVE
<input checked="" type="checkbox"/>	_____	_____

SUBSTITUTIONS:

Vendor will not substitute any item that has been awarded without prior written approval of the State Purchasing Bureau.

Notes/Alternative: _____

YES	NO	NO & PROVIDE ALTERNATIVE
<input checked="" type="checkbox"/>	_____	_____

BID COMPLIANCE:

Specifications have been read and fully understood. Any exceptions have been written on the bid or attached.

Notes/Alternative: _____

END OF SPECIFICATION

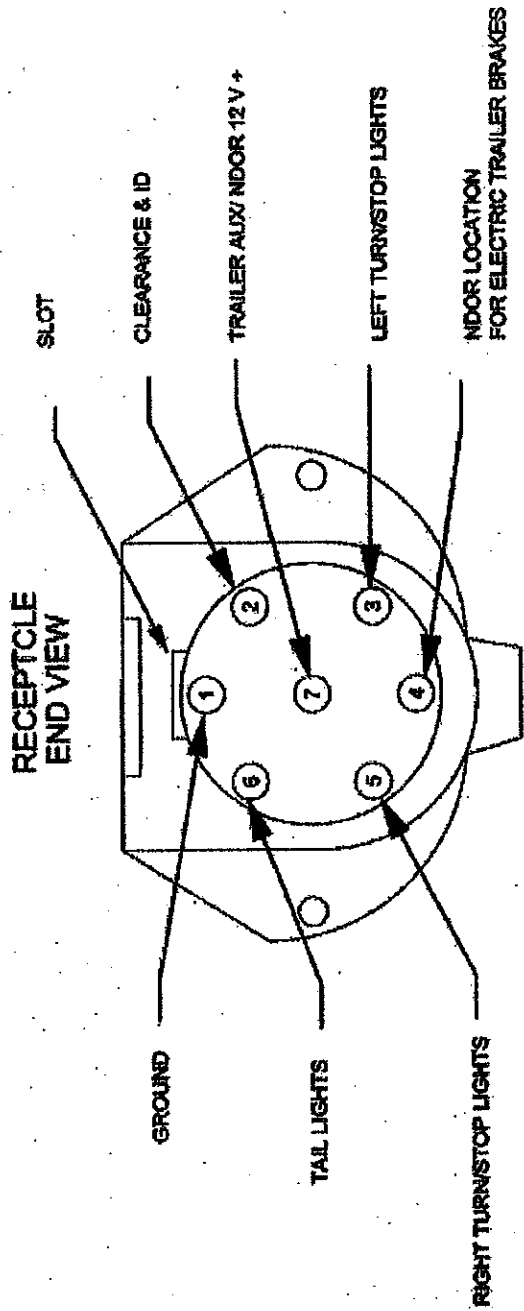

- 1. Wht: Ground
- 2. Black: Clearance/ ID
- 3. Yellow: Left Turn Signal/Stop Lights
- 4. Blue: Electric Trailer Brakes
- 5. Green: Right Turn Signal/Stop Lights
- 6 Brown: Tail Lamps
- 7. Red: Trailer Aux and 12 V Positive

NDOR
 STANDARD TRAILER CONNECTOR
 WIRING DIAGRAM
 DATE: 10-12-2011

ADDENDUM ONE

Date: September 10, 2013
To: All Bidders
From: Kristi Kling, Buyer
State Purchasing Bureau
RE: Addendum for Invitation to Bid 4487 OF
to be opened September 17, 2013 at 2:00 p.m.

There were no questions submitted for 4487 OF.

This addendum will become part of the bid and should be acknowledged with the ITB.

Dave Heineman, Governor

August 30, 2013

Dear Prospective Bidder:

The State of Nebraska Purchasing Bureau is issuing the following Invitation to Bid (ITB):

ITB Number:	4487 OF
Commodity:	Heated Rubberized Asphalt Crack Sealing Machine
Opening Date:	09/17/2013; 2:00 p.m. Central Time
Buyer:	Kristi Kling

Copies of 4486 OF and all information relevant to this ITB to include addenda and/or amendments may be obtained from the State Purchasing Bureau web site at:

<http://www.das.state.ne.us/materiel/purchasing/>

It is the responsibility of the bidder to check this site for other pertinent information and any mandatory requirements. All information relevant to this ITB, to include addenda and/or amendments that may be issued prior to the opening date, will be posted to the website.

ITB responses must be in a sealed envelope that indicates the ITB Number and Opening Date. Sealed responses must be received in the State Purchasing Bureau on or before 09/17/2013; 2:00 p.m. Central Time, at which time responses will be publicly opened. ITB response must be sent to:

State Purchasing Bureau
301 Centennial Mall South, Mall Level
Lincoln, NE 68508

OR

State Purchasing Bureau
PO Box 94847
Lincoln, NE 68509-4847

Any problems accessing the website regarding the above ITB should be e-mailed or faxed to the State Purchasing Bureau at as.materielpurchasing@nebraska.gov or 402-471-2089.

Sincerely,



Kristi Kling, Buyer
State Purchasing Bureau

State of Nebraska - INVITATION TO BID CONTRACT

Return to:
 State Purchasing Bureau
 301 Centennial Mall South, First Floor
 Lincoln, Nebraska 68508
 OR
 P.O. Box 94847
 Lincoln, NE 68509-4847
 Telephone: 402-471-2401
 Fax: 402-471-2089

Date	8/30/13	Page	1 of 4
Solicitation Number	4487 OF		
Opening Date and Time	09/17/13	2:00 pm	
Buyer	KRISTI KLING (AS)		

DESTINATION OF GOODS

DEPT OF ROADS
 5001 S 14TH ST
 PO BOX 94759
 LINCOLN NE 68509-4759

Contract to supply and deliver Heated Rubberized Asphalt Crack Sealing Machine, Min. 225 Gal. Capacity with Heated Hose to the State of Nebraska as per the attached specifications for a one (1) year period from date of award. The contract may be renewed for four (4) additional one (1) year periods when mutually agreeable to the vendor and the State of Nebraska. The State reserves the right to extend the period of this contract beyond the termination date when mutually agreeable to the vendor and the State of Nebraska.

The State may request that payment be made electronically instead of by state warrant. ACH/EFT Enrollment Form can be found at: <<http://www.das.state.ne.us/accounting/forms/achenrol.pdf>>

The Contractor is required and hereby agrees to use a federal immigration verification system to determine the work eligibility status of employees physically performing services within the State of Nebraska. A federal immigration verification system mean the electronic verification of the work authorization program authorized by the Illegal Immigration Reform and Responsibility Act of 1996, 8 U.S.C. 1324a, known as E-Verify Program, or an equivalent federal program designed by the United States Department of Homeland Security or other federal agency authorized to verify the work eligibility status of a newly hired employee.

The contractor, by signature to the Invitation to Bid, certifies that the contractor is not presently debarred, suspended, proposed for debarment, declared ineligible, or voluntarily excluded by any federal department or agency from participating in transactions (debarred). The contractor also agrees to include the above requirements in any and all subcontracts into which it enters. The contractor shall immediately notify the Department if, during the term of this contract, contractor becomes debarred. The Department may immediately terminate this contract by providing contractor written notice if contractor becomes debarred during the term of this contract.

If the Contractor is an individual or sole proprietorship, the following applies:

1. The Contractor must complete the United States Citizenship Attestation Form, available on the Department of Administrative Services website at: <http://das.nebraska.gov/lb403/attestation_form.pdf>
2. If the Contractor indicates on such attestation form that he or she is a qualified alien, the Contractor agrees to provide the US Citizenship and Immigration Services documentation require to verify the Contractor's lawful presence in the United States using the Systematic Alien Verification for Entitlements (SAVE) Program.
3. The Contractor understands and agrees that lawful presence in the United States is required and the Contractor may be disqualified or the contract terminated if such lawful presence cannot be verified as required by Neb. Rev. Stat. §4-108.

The contract resulting from the invitation to Bid shall incorporate the following documents:

1. Amendment to Contract Award with the most recent dated amendment having the highest priority;

No Bid Respond: () Remove From Class-Item OR () Keep Active For Class-Item

BIDDER MUST COMPLETE THE FOLLOWING

DISCOUNT PAYMENT TERMS: _____% _____ DAYS

By signing this Invitation to Bid, the bidder agrees to the "Standard Conditions and Terms of Bid Solicitation and Offer" and is committed to provide a drug free work place environment. Vendor will furnish the items requested within _____ days after receipt of order. Failure to enter Delivery Date may cause quotation to be REJECTED.

Sign _____
 Here (Authorized Signature MANDATORY - MUST BE SIGNED IN INK)

Enter Contact Information Below

VENDOR# _____
 VENDOR: _____
 Address: _____

Contact _____
 Telephone _____
 Facsimile _____
 Email _____

State of Nebraska - INVITATION TO BID CONTRACT

Return to:
State Purchasing Bureau
301 Centennial Mall South, First Floor
Lincoln, Nebraska 68508
OR
P.O. Box 94847
Lincoln, NE 68509-4847
Telephone: 402-471-2401
Fax: 402-471-2089

Date	8/30/13	Page	2 of 4
Solicitation Number	4487 OF		
Opening Date and Time	09/17/13	2:00 pm	
Buyer	KRISTI KLING (AS)		

DESTINATION OF GOODS

DEPT OF ROADS
5001 S 14TH ST
PO BOX 94759
LINCOLN NE 68509-4759

2. Contract Award and any attached Addenda;
3. The signed Invitation to Bid form and the Contractor's bid response;
4. Amendments to ITB and any Questions and Answers; and
5. The original ITB document and any Addenda.

These documents constitute the entirety of the contract.

Unless otherwise specifically stated in a contract amendment, in case of any conflict between the incorporated documents, the documents shall govern in the following order of preference with number one (1) receiving preference over all other documents and with each lower numbered document having preference over any higher numbered document: 1) Amendment to Contract Award with the most recent dated amendment having the highest priority, 2) Contract Award and any attached Addenda, 3) the signed Invitation to Bid form and the Contractor's bid response, 4) Amendments to ITB and any Questions and Answers, 5) the original ITB document and any Addenda.

Any ambiguity in any provision of this contract which shall be discovered after its execution shall be resolved in accordance with the rules of contract interpretation as established in the State of Nebraska.

Once Invitations to Bid are opened they become the property of the State of Nebraska and will not be returned.

It is understood by the parties that in the State of Nebraska's opinion, any limitation on the contractor's liability is unconstitutional under the Nebraska State Constitution, Article XIII, Section III and that any limitation of liability shall not be binding on the State of Nebraska despite inclusion of such language in documents supplied by the contractor's bid response.

08/29/2013 ld

A response to this Solicitation is subject to, but not limited to, the included Standard Conditions and Terms. PLEASE READ CAREFULLY!

IT IS THE RESPONSIBILITY OF THE BIDDER TO REFER TO STATE PURCHASING BUREAU'S WEB SITE FOR ALL INFORMATION RELEVANT TO THIS SOLICITATION TO INCLUDE ADDENDA AND/OR AMENDMENTS THAT MAY BE ISSUED PRIOR TO THE OPENING DATE.

<http://www.das.state.ne.us/materiel/purchasing/purchasing.html>

Bid Tabulations are available on the Internet at <http://www.das.state.ne.us/materiel/purchasing/bidtabs.htm>

This form is part of the specification package and must be signed and returned, along with all documents, by the opening date and time specified.

Any questions regarding this solicitation must be directed to State Purchasing Bureau, to the attention of the buyer. It is preferred that questions be sent via e-mail to matpurch.dasmat@nebraska.gov. Questions may also be sent by facsimile to 402-471-2089. Refer to specification for additional information.

No facsimile or email solicitation responses will be accepted.

State of Nebraska - INVITATION TO BID CONTRACT

Return to:
 State Purchasing Bureau
 301 Centennial Mall South, First Floor
 Lincoln, Nebraska 68508
 OR
 P.O. Box 94847
 Lincoln, NE 68509-4847
 Telephone: 402-471-2401
 Fax: 402-471-2089

Date	8/30/13	Page	3 of 4
Solicitation Number	4487 OF		
Opening Date and Time	09/17/13	2:00 pm	
Buyer	KRISTI KLING (AS)		

DESTINATION OF GOODS
 DEPT OF ROADS
 5001 S 14TH ST
 PO BOX 94759
 LINCOLN NE 68509-4759

INVITATION

Line	Description	Quantity	Unit of Measure	Unit Price	Extended Price
1	HEATED RUBBERIZED ASPHALT CRACK SEALING MACHINE MIN 225 Make: _____ Model: _____ Engine: _____	3.0000	EA	_____	_____
2	DEDUCT EQUIPMENT SHOP REPAIR MANUAL INDICATE PER UNIT COST	3.0000	EA	_____	_____
3	DEDUCT ENGINE SHOP REPAIR MANU INDICATE PER UNIT COST	3.0000	EA	_____	_____
4	DEDUCT EQUIPMENT PARTS MANUAL INDICATE PER UNIT COST	3.0000	EA	_____	_____
5	DEDUCT ENGINE PARTS MANUAL INDICATE PER UNIT COST	3.0000	EA	_____	_____
6	DEDUCT FOR NO TRAILER MOUNT AIR COMPRESSOR W/HOSE & REEL	3.0000	EA	_____	_____
7	110 VOLT, HEATING ELEMENTS FOR OVERNIGHT HEATING W/CONTROLS	3.0000	EA	_____	_____
8	PRICE FOR ADDITIONAL HEATED HOSE W/SLEEVE	3.0000	EA	_____	_____

STANDARD CONDITIONS AND TERMS OF BID SOLICITATION AND OFFER Invitations to Bid and Contract Awards

It is the responsibility of the bidder to check the website for all information relevant to this solicitation to include addenda and/or amendments issued prior to the opening date. Website address: <http://www.das.state.ne.us/materiel/purchasing/purchasing.htm>

SCOPE- These standard conditions and terms of bid solicitation and acceptance apply in like force to this inquiry and to any subsequent contract resulting therefrom.

PRICES- Prices quoted shall be net, including transportation and delivery charges fully prepaid by the bidder, F.O.B. destination named in the Invitation to Bid. No additional charges will be allowed for packing, packages or partial delivery costs. When an arithmetic error has been made in the extended total, the unit price will govern.

EXECUTION- Bids must be signed in ink by the bidder on the State of Nebraska's Invitation to Bid form. All bids must be typewritten or in ink on the State of Nebraska's Invitation to Bid form. Erasures and alterations must be initiated by the bidder in ink. No telephone or voice bids will be accepted. Failure to comply with these provisions may result in the rejection of the bid.

FACSIMILE DOCUMENTS- The State Purchasing Bureau will only accept facsimile responses to Invitations to Bid on bids under \$25,000 and up to ten (10) pages. However, two party sealed bids containing facsimile pages are acceptable. No direct facsimile solicitation responses will be accepted for a commodity contract.

VALID BID TIME- Bids shall be firm for a minimum of sixty (60) calendar days after the opening date, unless otherwise stipulated by either party in the Invitation to Bid.

DISCOUNTS- Prices quoted shall be inclusive of ALL trade discounts. Cash discount terms of less than thirty (30) days will not be considered as part of the bid. Cash discount periods will be computed from the date of receipt of a properly executed claim voucher or the date of completion of delivery of all items in a satisfactory condition, whichever is later.

PAYMENT- Payment will be made by the responsible agency in conjunction with the State of Nebraska Prompt Payment Act 81-2401 through 2408. The State may request that payment be made electronically instead of by state warrant.

COLLUSIVE BIDDING- The bidder guarantees that the prices quoted have been arrived at without collusion with other eligible bidders and without effort to preclude the State of Nebraska from obtaining the lowest possible competitive price.

LUMP SUM OR ALL OR NONE BIDS- The State reserves the right to purchase item-by-item, by groups or as a total when the State may benefit by so doing. Bidders may submit a bid on an "all or none" or "lump sum" basis but should also submit a bid on an item-by-item basis. The term "all or none" means a conditional bid which requires the purchase of all items on which bids are offered and bidder declines to accept award on individual items; a "lump sum" bid is one in which the bidder offers a lower price than the sum of the individual bids if all items are purchased but agrees to deliver individual items at the prices quoted.

SPECIFICATIONS- Any manufacturer's names, trade names, brand names, information and/or catalog numbers listed in a specification are for reference and not intended to limit competition, but will be used as the standard by which equivalent material offered will be judged. The State Purchasing Director will be the sole judge of equivalency. The bidder may offer any brand which meets or exceeds the specification. When a specific product is required, the invitation to bid will so state. Any item bid is to be the latest current model under standard production at the time of order. No used or refurbished equipment will be accepted, unless otherwise stated.

ALTERNATE/EQUIVALENT BIDS- Bidder may offer bids which are at variance from the express specifications of the Invitation to Bid. The State reserves the right to consider and accept such bids if, in the judgement of the State Purchasing Director, the bid will result in goods and/or services equivalent to or better than those which would be supplied in the original bid specifications. Bidders must indicate on the invitation to bid the manufacturer's name, number and shall submit with their bid, sketches, descriptive literature and/or complete specifications. Reference to literature submitted with a previous bid will not satisfy this provision. Bids which do not comply with these requirements are subject to rejection. In the absence of any stated deviation or exception, the bid will be accepted as in strict compliance with all terms, conditions and specifications, and the bidder shall be held liable therefore.

SAMPLES- When requested, samples shall be furnished at the bidders expense prior to the opening of the bid, unless otherwise specified. Each sample must be labeled clearly and identify the bidders name, the invitation to bid number and the item number. Samples submitted must be representative of the commodities or equipment which would be delivered if awarded the bid. The State of Nebraska reserves the right to request samples even though this may not have been set forth in the invitation to bid. Samples not destroyed in testing will be returned at bidders expense, if requested, or will be donated to a public institution.

RECYCLING- Preference will be given to items which are manufactured or produced from recycled material or which can be readily reused or recycled after their normal use as per State Statute Section 81-15,159.

LATE BIDS- All bids will be time and date stamped upon receipt by the State Purchasing Bureau, and this shall be the official time and date of receipt. Bids received after the time of the bid opening will be considered late bids and will be returned to the bidder unopened. The State Purchasing Bureau is not responsible for late bids or lost requests due to mail service inadequacies, traffic or other similar reasons.

BID OPENING- Openings shall be public on the date and time specified on the invitation to bid form. It is the bidder's responsibility to assure the bid is delivered at the designated date, time and place of the bid opening. Telephone bids are not acceptable. A bid may not be altered after opening of the bids.

NO BID- If not submitting a bid, respond by returning the invitation to bid form explaining the reason in the space provided. Failure to respond to an Invitation to Bid may be cause for the removal of the bidder's name from the mailing list. NOTE: To qualify as a respondent, bidder must submit a "NO BID" and it must be received no later than the stated bid opening date and time.

AWARD- All purchases, leases, or contracts which are based on competitive bids will be awarded to the lowest responsible bidder, determined according to the provisions of State Statute Section 81-161, R.R.S. 1943. The State reserves the right to reject any or all bids, wholly or in part and to waive any deviations or errors that are not material, do not invalidate the legitimacy of the bid and do not improve the bidders competitive position. All awards will be made in a manner deemed in the best interest of the State.

BID TABULATIONS- Tabulations will be furnished upon written request. A self-addressed, stamped envelope which must include the agency and solicitation number must be enclosed. Bid tabulations will not be provided by telephone or facsimile. Bid files may be examined during normal working hours by appointment. Bid tabulations are available on the website at: <http://www.das.state.ne.us/materiel/purchasing/bidtabs.htm>

PERFORMANCE AND DEFAULT- The State reserves the right to require a performance bond from the successful bidder, as provided by law, without expense to the State. Otherwise, in case of default of the contractor, the State may procure the articles from other sources and hold the contractor responsible for any excess cost occasioned thereby.

IN-STATE PREFERENCE- A resident bidder shall be allowed a preference against a nonresident from a state which gives or requires a preference to bidders from that state. The preference shall be equal to the preference given or required by the state of the nonresident bidders. Where the lowest responsible bid from a resident bidder is equal in all respects to one from a nonresident bidder from a state which has no preference law, the resident bidder shall be awarded the contract.

NONDISCRIMINATION- The Nebraska Fair Employment Practice Act prohibits contractors of the State of Nebraska, and their subcontractors, from discriminating against any employee or applicant for employment, to be employed in the performance of such contracts, with respect to hire, tenure, terms, conditions or privileges of employment because of race, color, religion, sex, disability, or national origin. (State Statute Sections 48-1101 through 48-1125) The bidder guarantees compliance with the Nebraska Fair Employment Practice Act, and breach of this provision shall be regarded as a material breach of contract. The contractor shall insert a similar provision in all subcontracts for services to be covered by any contract resulting from this invitation to bid.

TAXES- Purchases made by the State of Nebraska are exempt from the payment of Federal Excise Taxes, and exemption certificates will be furnished on request. State and local taxes are exempt by State Statute Section 77-2704 (f) (m) R.R.S. 1943 and must not be included in the bid prices. Exemption by statute precludes the furnishing of State exemption certificates.

DRUG POLICY - Bidder certifies that it maintains a drug free work place environment to ensure worker safety and workplace integrity. Contractor agrees to provide a copy of its drug free workplace policy at any time upon request by the State.

GRIEVANCE AND PROTEST- Grievance and protest procedure is available by contacting the buyer. Protest must be filed within ten (10) days of award.

NE ACCESS TECHNOLOGY STANDARDS- Vendor agrees to ensure compliance with Nebraska Access Technology Standards. See website at: <http://www.nitc.state.ne.us/standards/accessibility/>

**STATE OF NEBRASKA
STATE PURCHASING BUREAU**

SCHEDULE OF EVENTS

The State expects to adhere to the tentative procurement schedule shown below. It should be noted, however, that some dates are approximate and subject to change.

	ACTIVITY	DATE/TIME
1	Release Invitation to Bid	August 30, 2013
2	Last Day to Submit Written Questions	September 6, 2013
3	State Responds to Written Questions Through an Addendum to be posted to the internet at: http://www.das.state.ne.us/materiel/purchasing/rfp.htm	September 10, 2013
4	Bid Opening Location: Nebraska State Office Building State Purchasing Bureau 301 Centennial Mall South, Mall Level Lincoln, NE 68508	September 17, 2013 2:00 p.m. Central Time

WRITTEN QUESTIONS AND ANSWERS

Any explanation desired by a bidder regarding the meaning or interpretation of any Invitation to Bid provision must be submitted in writing to the State Purchasing Bureau and clearly marked 4487 OF; Heated Rubberized Asphalt Crack Sealing Machine, Minimum 225 Gallon Capacity with Heated Hose. It is preferred that questions be sent via e-mail to matpurch.dasmat@nebraska.gov. Questions may also be sent by facsimile to 402-471-2089, but must include a cover sheet clearly indicating that the transmission is to the attention of Kristi Kling, showing the total number of pages transmitted, and clearly marked "4487 OF; Heated Rubberized Asphalt Crack Sealing Machine, Minimum 225 Gallon Capacity with Heated Hose".

Written answers will be provided through an addendum to be posted on the internet at <http://www.das.state.ne.us/materiel/purchasing/rfp.htm> on or before the date shown in the Schedule of Events.

STATE OF NEBRASKA
DEPARTMENT OF ROADS

**Terms and Conditions for
Heated Rubberized Asphalt Crack Sealing Machine,
Minimum 225 Gallon Capacity with Heated Hose**

W16-13

SCOPE

THE Heated Rubberized Asphalt Crack Sealing Machine, Minimum 225 Gallon Capacity with Heated Hose SHALL BE THE LATEST CURRENT MODEL OF PROVEN PERFORMANCE AND UNDER STANDARD PRODUCTION BY THE MANUFACTURER AND IS TO BE OF STANDARD DESIGN, COMPLETE AS REGULARLY ADVERTISED AND MARKETING INCLUDING ALL SPECIFIED ACCESSORIES, TOOLS AND SPECIAL FEATURES. All necessary parts for satisfactory operation of the equipment shall be furnished whether or not they may be specifically mentioned below. Complete detailed specifications and advertising data sheets with cuts or photographs should be attached to the invitation to bid on the IDENTICAL equipment proposed. ANY INFORMATION NECESSARY TO SHOW COMPLIANCE WITH THESE SPECIFICATIONS, IN ADDITION TO INFORMATION GIVEN ON ADVERTISING DATA SHEETS, SHOULD BE SUPPLIED IN WRITING AND ATTACHED TO THE BID DOCUMENT. The Heated Rubberized Asphalt Crack Sealing Machine, Minimum 225 Gallon Capacity with Heated Hose must meet or exceed the following requirements.

NON-COMPLIANCE STATEMENT

Read this specification carefully. Any and all exceptions to this specification must be written on or attached to invitation to bid. Non-compliance can void your bid. It is the responsibility of the Bidders to obtain information and clarifications as provided on the Schedule of Events. The State of Nebraska is not responsible for any erroneous or incomplete understandings or wrongful interpretations of this Invitation to Bid by any Bidder.

PERIOD OF CONTRACT

Contract to supply and deliver Heated Rubberized Asphalt Crack Sealing Machine, Minimum 225 Gallon Capacity with Heated Hose to various locations upon request per the attached specifications, terms and conditions for a one (1) year period beginning from date of contract award with the option to renew for four (4) additional one (1) year periods when mutually agreeable to the vendor and the State of Nebraska. The State reserves the right to extend the period of this contract beyond the termination date when mutually agreeable to the vendor and the State of Nebraska.

AMENDMENT

This Contract may be amended at any time in writing upon the agreement of both parties.

RIGHTS

The State of Nebraska reserves the right to waive technicalities and reject any or all bids. The State of Nebraska will be the sole judge of equivalence and any decision will be final.

Contract supplier or suppliers may honor pricing and extend the contract to political sub-divisions, cities and counties. Terms and conditions of the contract must be met by political sub-divisions, cities and counties. Under no circumstances shall the State of Nebraska be contractually obligated or liable for any purchases by political sub-divisions, cities or counties.

TERMINATION

The Contract may be terminated at any time upon the mutual consent of the parties, or by either party, with or without cause, upon thirty (30) days written notice to the other party.

BREACH OF CONTRACT

If the Contractor breaches this Contract, the State of Nebraska may, at its discretion, terminate the contract immediately upon written notice to the Contractor. The State of Nebraska shall pay the Contractor only for such performance as has been properly completed and is of use to the State of Nebraska. The State of Nebraska may, at its discretion, contract for

provision of the goods or services required to complete this Contract and hold the Contractor liable for all expenses incurred in such additional contract over and above the total cost of performance. This provision shall not preclude the pursuit of other remedies for breach of contract as allowed by law.

ANNUAL USAGE

This is an open-ended contract between the vendor and the State to furnish an undetermined quantity of **Heated Rubberized Asphalt Crack Sealing Machine, Minimum 105 Gallon Capacity with Heated Hose** in a given period of time. Quantities stated are estimates only and shall not be construed to either be a minimum or a maximum.

ORDERS/INVOICES

The ordering entity will submit their orders directly to the contractor on an as needed basis, using their own standard purchase order form. Orders may be placed by phone, fax, mail, or Internet (if available). All orders must be assigned a purchase order number, and the purchase order must be referenced on the invoice. All invoices are to be sent to the address shown on the purchase order.

DELIVERY

Between 9:00 AM and 3:00 PM, daily, except Saturdays, Sundays and holidays. Delivery desired prior to 60 days after receipt of purchase order; deliveries quoted beyond 60 days are an award consideration. Vendor must notify Fleet Management minimum of 24 hours prior to delivery on workday basis at (402) 479-4319 or 479-4323. Department of Roads' equipment will be delivered to 5001 South 14th Street, Lincoln, Nebraska.

ACCEPTABLE BRANDS

Cimline

Crafco

Other brands must be demonstrated near Lincoln, Nebraska, have adequate references provided, have adequate service facilities in Nebraska, be field proven and be approved in writing by Fleet Management of the Department of Roads five (5) days prior to bid opening.

**STATE OF NEBRASKA
DEPARTMENT OF ROADS**

**Specification for
Heated Rubberized Asphalt Crack Sealing Machine,
Minimum 225 Gallon Capacity with Heated Hose**

Bidder instructions:

Bidder must respond to each of the following statements. Specifications listed are minimum conditions that must be met in order for a bidder to qualify for the award.

MEETS SPECIFICATIONS – Please indicate – (If response is No & Provide Alternative, explain on Notes/Alternative line)

YES	NO	NO & PROVIDE ALTERNATIVE
_____	_____	_____
_____	_____	_____

QUALITY:

1. Products must meet specifications and be of first quality, free of damage and/or defect and must be under standard production by the manufacturer and be of standard design, complete as regularly advertised and marketed and be of proven performance. A guarantee of satisfactory performance of the product, performance of the supplier, and the supplier meeting delivery dates are all considered to be integral parts of the contract resulting from this bid invitation.

2. Failure to conform to the Specifications and Terms and Conditions constitutes a breach of this contract, and the State may reject the entire order or any part thereof and may recover the expenses and/or damages of such breach. The State of Nebraska may, also at its discretion, terminate the contract immediately upon written notice to the contractor and/or pay the contractor only for such performance as has been properly completed and is of use to the State and contract for provision of the services required to complete this contract and hold the contractor liable for all expenses incurred in such additional contract over and above the total cost of performance. This provision shall not preclude the pursuit of other remedies for breach of contract as allowable by law.

Notes/Alternative: _____

YES	NO	NO & PROVIDE ALTERNATIVE
_____	_____	_____

PRICE:

Prices quoted shall be unit price (each) and shall be firm for 90 days from date of an award and are to be net, including transportation and delivery charges fully prepaid by the bidder F.O.B. destination as specified on each Purchase Order or under separate cover with each order. No additional charges will be allowed for packing, handling, or partial delivery costs. Any request for an increase must be submitted in writing to the State Purchasing Bureau a minimum of 30 days prior to proposed effective date of increase, and must show cause and be accompanied by supporting documentation (such as notification letter from the manufacturer). Supporting documentation must clearly establish the increase is to all customers, not to the State of Nebraska alone. Further documentation may be required by the State, to authenticate the increase (manufacturer invoices). Failure to supply any requested supporting documentation may be grounds to cancel the contract. The State further reserves the right to reject any proposed price increase(s), cancel the contract and re-bid if determined to be in the best interest of the State. No price increases are to be billed to any State Agencies without *prior* written approval by the State Purchasing Bureau. The State will be given full

proportionate benefit of any decrease for the term of the contract.

Notes/Alternative: _____

YES	NO	NO & PROVIDE ALTERNATIVE	
_____	_____	_____	1. MELTING VAT SYSTEM
_____	_____	_____	A. Mixing/holding tank shall be of double boiler construction
_____	_____	_____	B. Minimum 225 gallon capacity material tank
_____	_____	_____	C. Minimum 10 gauge steel vat
_____	_____	_____	D. 50 to 550 degrees Fahrenheit dial stem or digital thermometer
_____	_____	_____	E. Full length agitator with dual blades or auger system to break up and blend material; surrounded by minimum 12 gauge steel oil jacket
_____	_____	_____	F. Hot oil expansion tank required if available from manufacturer
_____	_____	_____	G. The heating jacket will have a 50-550 degrees Fahrenheit dial stem or digital thermometer
_____	_____	_____	1. Oil filler cap and dipstick
_____	_____	_____	2. Insulated by minimum 2" of fiberglass or 1" of ceramic
_____	_____	_____	3. Insulated encased in a minimum 22 gauge shell
_____	_____	_____	H. Anti-splash or safety loading chute with minimum 250 square inch opening required

Notes/Alternative: _____

YES	NO	NO & PROVIDE ALTERNATIVE	
_____	_____	_____	2. HEATING SYSTEM
_____	_____	_____	A. Diesel fueled by minimum 275,000 BTU burner
_____	_____	_____	B. Capable of melting rubberized asphalt at the minimum rate of about 200 gallons per hour or 1,700 pounds per hour after initial heat-up
_____	_____	_____	C. Burner chamber shall have minimum 5,000 square inch heat transfer area that exhausts to vertical stack with rain cover(s), and have heat transfer efficiency rating of at least 94%
_____	_____	_____	D. Burners will be equipped with a fully automatic thermostatic oil temperature control system with a pressure regulator and gauge
_____	_____	_____	E. Outfire shutoff valve and a built-in, self-contained electric ignition system
_____	_____	_____	F. All unit controls will be in a weather-tight lockable box

Notes/Alternative: _____

YES	NO	NO & PROVIDE ALTERNATIVE	
_____	_____	_____	3. SEALANT AND APPLICATOR SYSTEM
_____	_____	_____	A. Sealant will be circulated and delivered through a hydraulically driven minimum 12 GPM pump OR a 6 GPM pump if "pump on demand" system is used.
_____	_____	_____	1. Pump to be external of material tank and within heated enclosure
_____	_____	_____	B. Unit is to be equipped with electrically heated hose
_____	_____	_____	1. Unit shall have a heated enclosure to provide storage and provision for using a non-heated hose as various conditions and operations occur
_____	_____	_____	C. Sealant delivery hose shall allow for a 14' working radius from the rear center of the machine
_____	_____	_____	1. Continuously heated by 110 volt or 12 volt electrically heated hose and wand
_____	_____	_____	2. Trigger control wand preferred. If <u>not</u> furnishing trigger control wand, please state what you are furnishing:

W16-13

_____	_____	_____
_____	_____	_____
_____	_____	_____
_____	_____	_____

3. Rated for minimum 500 degrees Fahrenheit temperature
4. Steel braided with Teflon lining or equivalent
5. Protected by separate hose sheath
- C. Pressure-regulating device will be provided to regulate pressure from applicator nozzle if not "pump on demand" system
- D. Swing arm boom for support of application hose is required

Notes/Alternative: _____

YES	NO	NO & PROVIDE ALTERNATIVE
_____	_____	_____
_____	_____	_____
_____	_____	_____
_____	_____	_____
_____	_____	_____
_____	_____	_____
_____	_____	_____

- 4. ENGINE AND DRIVE**
- A. Diesel, minimum of 25 horsepower
 - B. 12 volt electric start
 - C. Battery, alternator, and rainproof muffler(s)
 - D. Power transmitted through hydraulic pumps and motors in such a fashion that pump and agitator can be operated together or separately in either forward or reverse rotation
 - E. Hourmeter connected to engine is required
 - F. A minimum 25 gallon diesel fuel tank for engines and burners required
 - G. Liquid cooled engines will be protected to minimum 34 degrees below zero Fahrenheit with ethylene glycol solution
 - H. Engine cover required

Notes/Alternative: _____

YES	NO	NO & PROVIDE ALTERNATIVE
_____	_____	_____
_____	_____	_____
_____	_____	_____
_____	_____	_____
_____	_____	_____
_____	_____	_____
_____	_____	_____
_____	_____	_____
_____	_____	_____
_____	_____	_____
_____	_____	_____
_____	_____	_____

- 5. TRAILER UNIT**
- A. Single or dual axle minimum 6,800 pound rating, adequate suspension to meet requirement of fully loaded machine
 - B. Steel disc wheels desired
 - C. Electric brake system required
 1. 12" x 2" brakes on both axles with safety breakaway
 2. Each axle **shall be** wired to an individual circuit breaker. Circuit breakers may be dealer installed.
 3. A 12 volt breakaway safety switch with necessary electrical wiring shall be included at front of tongue
 4. Brake system shall be DOT compliant for the State of Nebraska
 - D. Tires shall be of adequate size and load range to meet GVWR of trailer. State size and load range of tire to be provided:
 - E. Tires should be Bridgestone, Goodyear, BF Goodrich, Michelin, Firestone, General, Titan, or Uniroyal, and carry said brand name. If manufacturer cannot furnish above brand name tires, please specify what brand you will be furnishing:
 - F. Fenders and license plate bracket required
 - G. Running lights conforming to federal requirements
 - H. 3" towing eye with height adjustments approximately 20-30" from grade in about 2" increments
 - I. Adjustable tongue jack with caster
 - J. Frame fabricated to adequately support the machine
 - K. Safety chains with hooks and retaining ability from trailer to pulling unit are required
 - L. Electrical connecter of 7-way ATA type from trailer to towing vehicle; wired

per instructions with plug (see attached drawing)

- M. Trailer unit to have mounted rotary vane or rotary screw type air compressor
 1. Compressor to have minimum 50 CFM and 100psi rating
 2. 50' hose on an integrated retracting hose reel shall be supplied. Hose reel may be dealer installed in suitable and convenient location.

_____	_____	_____
_____	_____	_____
_____	_____	_____

Notes/Alternative: _____

YES	NO	NO & PROVIDE ALTERNATIVE
_____	_____	_____

6. NOISE LEVEL

- A. Bidder shall supply with proposal the following decibel level per SAE Standards:
Under full load in operator's position with doors and windows open

Under full load in bystander's position at 7.5 meters from rear of unit

Notes/Alternative: _____

YES	NO	NO & PROVIDE ALTERNATIVE
_____	_____	_____
_____	_____	_____
_____	_____	_____
_____	_____	_____
_____	_____	_____

7. MANUALS

- A. Operator's manual must accompany each unit delivered
- B. Equipment shop repair manual is required with each unit delivered
- C. Equipment parts manual is required with each unit delivered
- D. Engine shop repair manual is required with each unit delivered
- E. Engine parts manual is required with each unit delivered
- F. All manual(s) must be furnished prior to payment and delivered to Fleet Management, Equipment Data Coordinator. Failure to deliver all manuals that are ordered may result in non-payment of ten percent (10%) of purchase order until all manuals are delivered.

Notes/Alternative: _____

YES	NO	NO & PROVIDE ALTERNATIVE
_____	_____	_____
_____	_____	_____
_____	_____	_____
_____	_____	_____

8. MISCELLANEOUS

- A. Bidder will submit with their proposal a list of any special tools they will furnish with each machine
- B. Dealer's decals, stickers or other signs shall not be affixed to units; manufacturer's nameplates, stampings and other similar signs are acceptable
- D. Dealer pre-delivery service required
- E. Color – manufacturer's standard color, but black is preferred. Unit will be primed prior to final coat.

Notes/Alternative: _____

YES	NO	NO & PROVIDE ALTERNATIVE
_____	_____	_____
_____	_____	_____

9. WARRANTY

- A. Manufacturer's usual warranty shall apply and shall be in effect for at least one (1) year from the date the equipment is placed in service by the Nebraska Department of Roads (NDOR)
 1. This warranty shall cover all inspected parts determined to have been defective in material or workmanship.

W16-13

_____	_____	_____
_____	_____	_____
_____	_____	_____

- B. Vendor shall be responsible for all repairs, to include parts and labor, during the 12 month usual warranty period
- C. All transportation costs to and from the nearest authorized repair facility will be the responsibility of the NDOR
- D. Authorized repair facility to be located in Nebraska. Please list authorized repair facilities:

Notes/Alternative: _____

YES	NO	NO & PROVIDE ALTERNATIVE
_____	_____	_____
_____	_____	_____
_____	_____	_____

10. SPECIFICATION FORM

- A. Successful bidder will be required to complete form to the fullest extent possible for each unit and must accompany each unit when delivered.
- B. Forms will be supplied by the Department of Roads to successful bidder after contract is awarded.
- C. If vendor does not properly complete form for each unit, a sum of \$250.00 per unit will be deducted from purchase order amount.

Notes/Alternative: _____

YES	NO	NO & PROVIDE ALTERNATIVE
_____	_____	_____

11. TRAINING

- A. Successful bidder must furnish a factory-trained representative in operation maintenance for eight (8) hours of instruction for each unit at its location within the State of Nebraska. Fleet Management will contact vendor regarding schedule.

Notes/Alternative: _____

YES	NO	NO & PROVIDE ALTERNATIVE
_____	_____	_____

SUBSTITUTIONS:

Vendor will not substitute any item that has been awarded without prior written approval of the State Purchasing Bureau.

Notes/Alternative: _____

YES	NO	NO & PROVIDE ALTERNATIVE
_____	_____	_____

BID COMPLIANCE:

Specifications have been read and fully understood. Any exceptions have been written on the bid or attached.

Notes/Alternative: _____

END OF SPECIFICATION

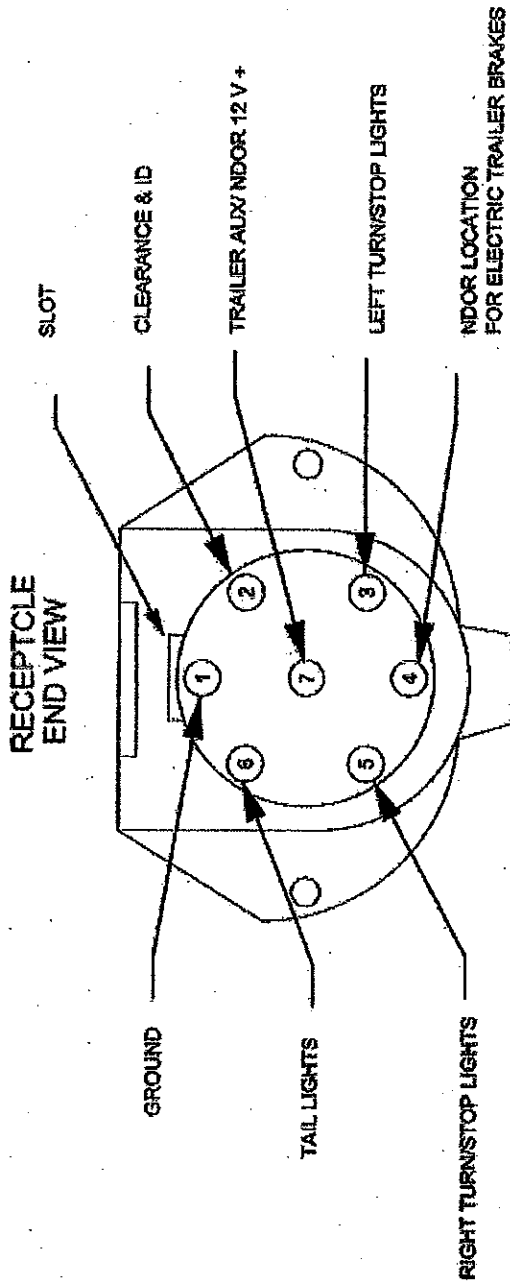

- 1. Wht: Ground
- 2. Black: Clearance/ ID
- 3. Yellow: Left Turn Signal/Stop Lights
- 4. Blue: Electric Trailer Brakes
- 5. Green: Right Turn Signal/Stop Lights
- 6 Brown: Tail Lamps
- 7. Red: Trailer Aux and 12 V Positive

NDOR
STANDARD TRAILER CONNECTOR
WIRING DIAGRAM
DATE: 10-12-2011